

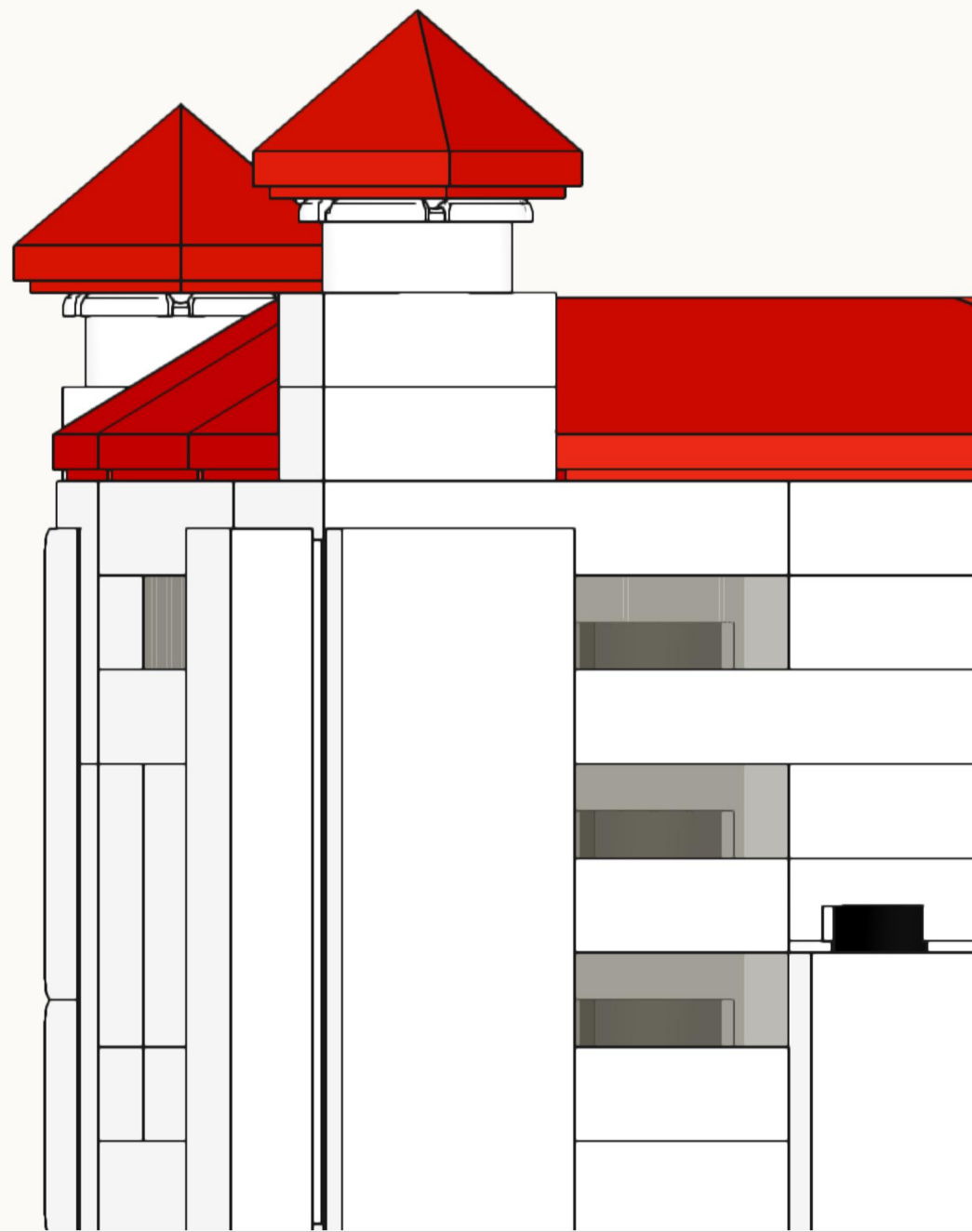

Bratislavský hrad je historická pevnosť s výhľadom na rieku Dunaj v Bratislave. Jeho pôvod siaha až do 9. storočia, hoci miesto bolo osídlené už od doby kamennej. Hrad sa stal dôležitým politickým a kráľovským sídlom **Uhorského kráľovstva**, kde pobývali uhorskí králi a neskôr aj cisárovná Mária Terézia v 18. storočí.

Hrad bol zničený požiarom v roku 1811 a zostal v ruinách až do svojej rekonštrukcie v polovici 20. storočia. Dnes je sídlom **Slovenského národného múzea** a symbolom slovenskej histórie a kultúrneho dedičstva.

Jeho typická obdĺžniková stavba so štyrmi nárožnými vežami, vrátane **Korunnej veže**, ponúka panoramatický výhľad na mesto a Dunaj.



BRATISLAVSKÝ HRAD – MOC KIT

	KIT GB-003	JEDNOTKY	ŠÍRKA	DĹŽKA	VÝŠKA
	MIKRO MIERKA	ŠTUDY	11.0	10.0	6.0
	184 DIELOV	PALCE	3.5	3.1	1.9
	NAVRHNUTÉ V 2025	CENTIMETRE	8.8	8.0	4.8

Tento MOC set je založený na originálnom MOC modeli (My Own Creation), ktorý navrhol **The Bobby Brix Channel**. Dizajn a stavebný návod zostávajú majetkom The Bobby Brix Channel, registrovaného pod spoločnosťou SREDA s.r.o. Pre viac informácií alebo povolenia týkajúce sa ďalšieho predaja, veľkoobchodu, výstav či komerčného využitia, prosím kontaktujte The Bobby Brix Channel na stránke **bobbybrix.com**.

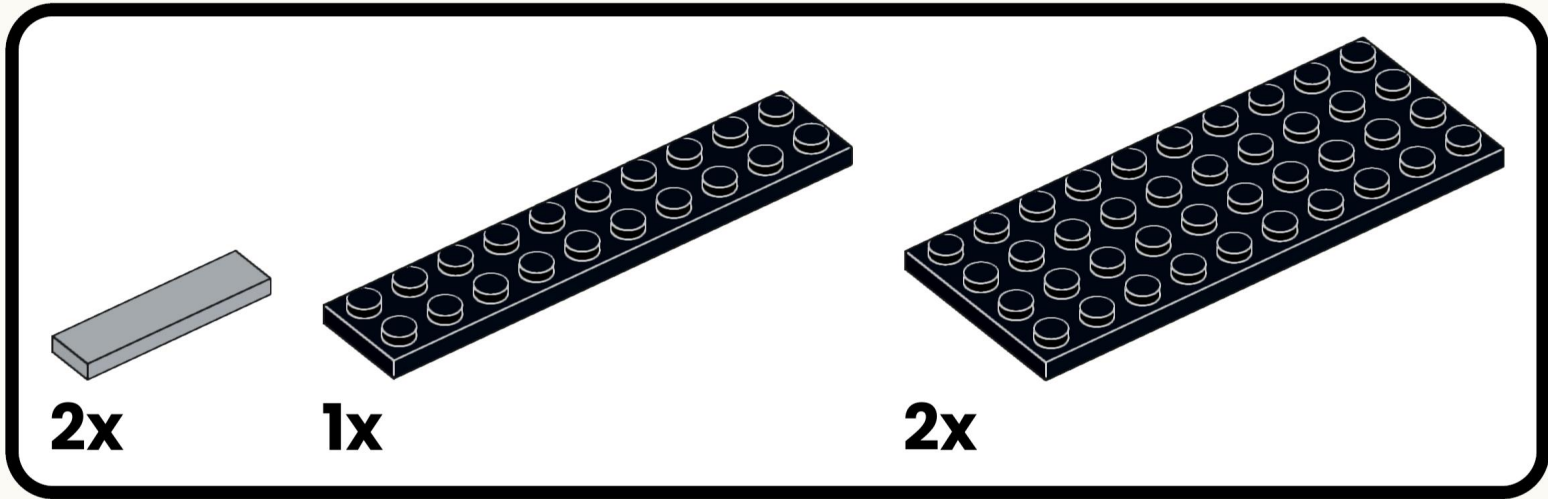

1

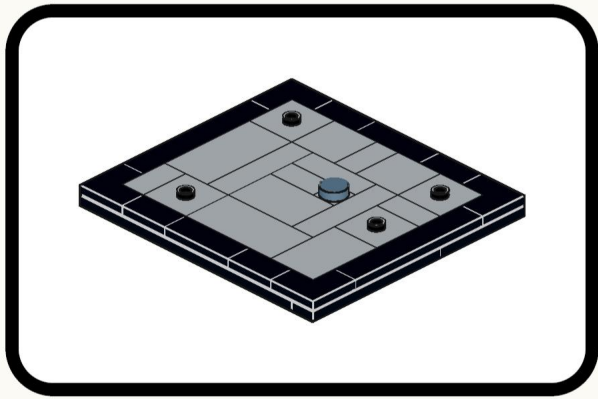
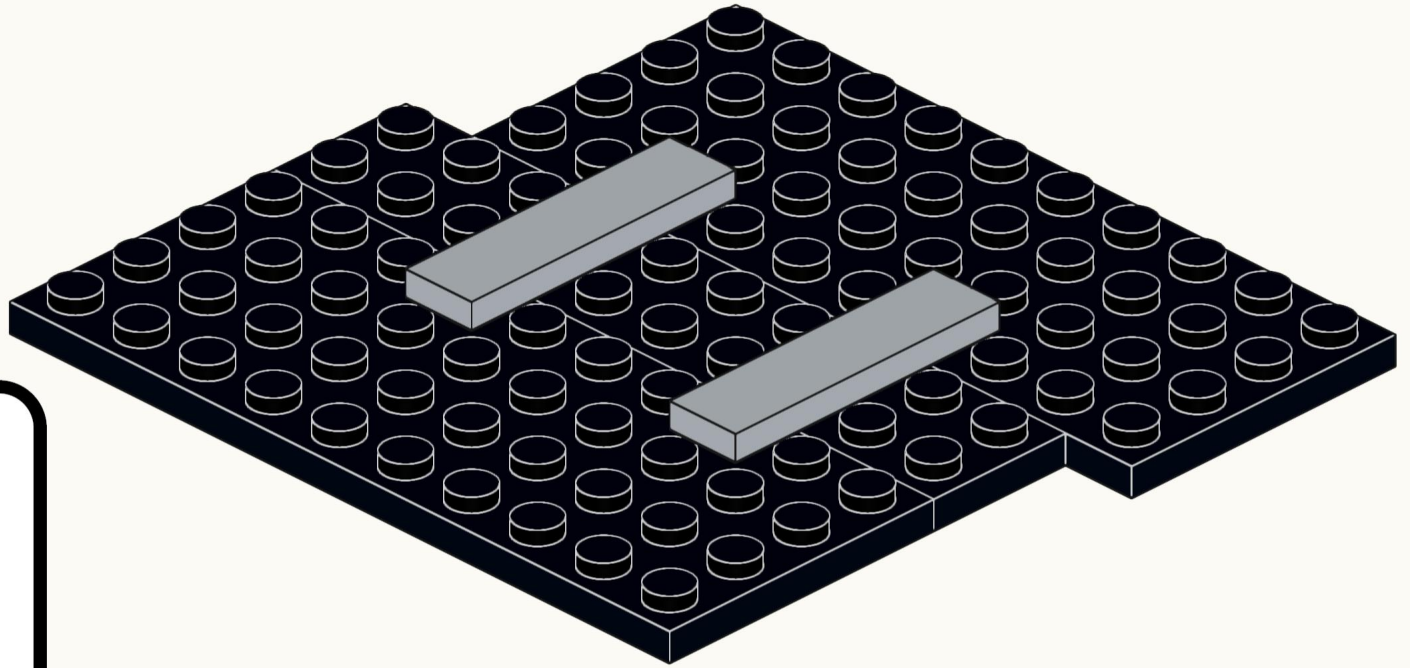

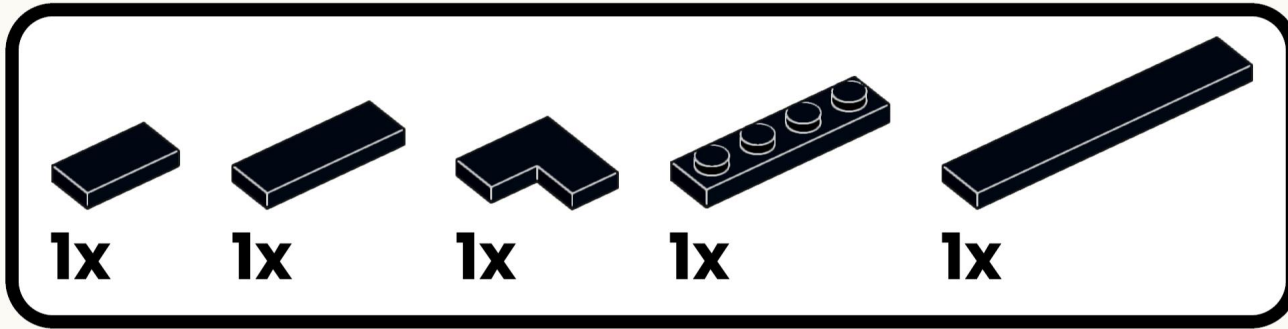

2

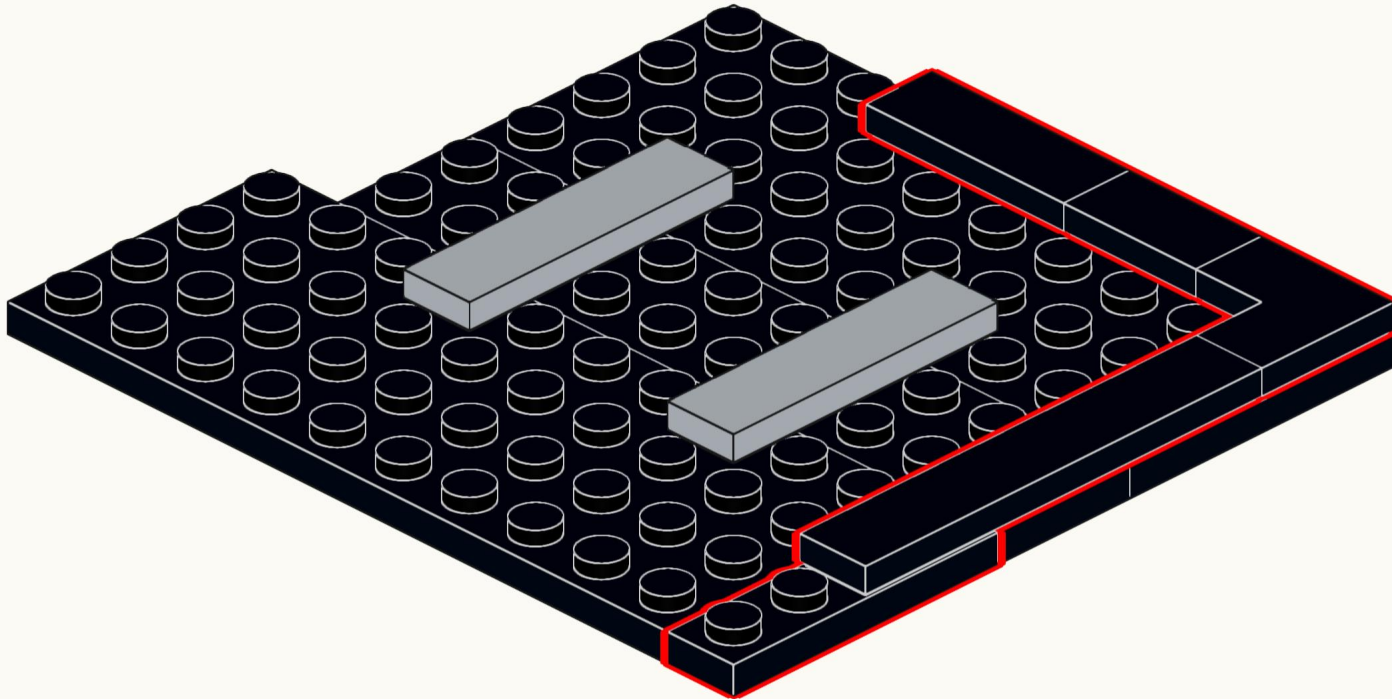

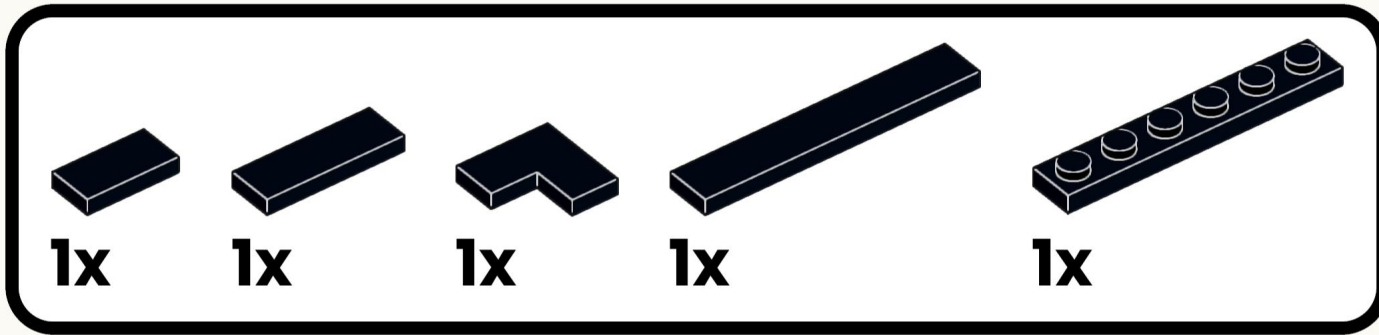

3

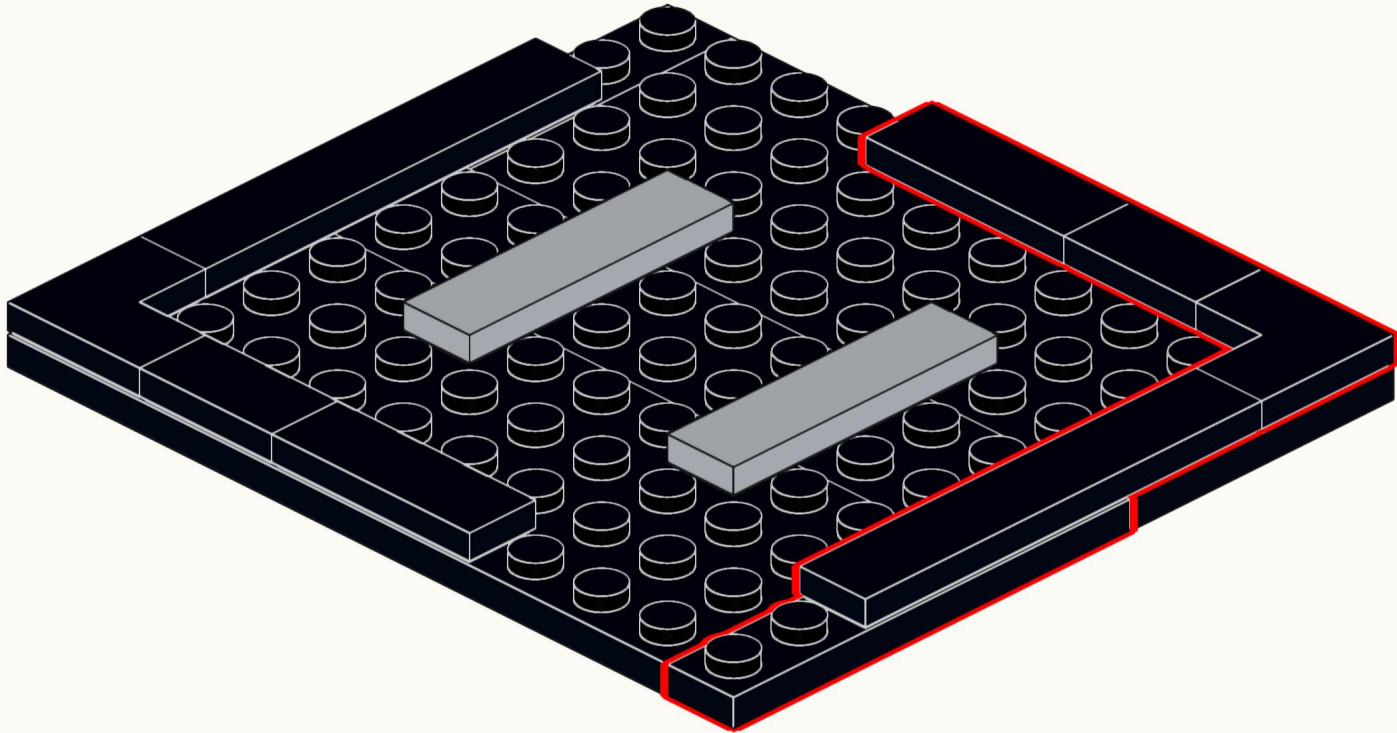

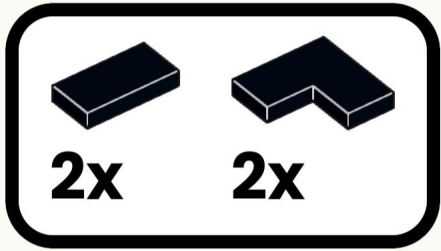

4

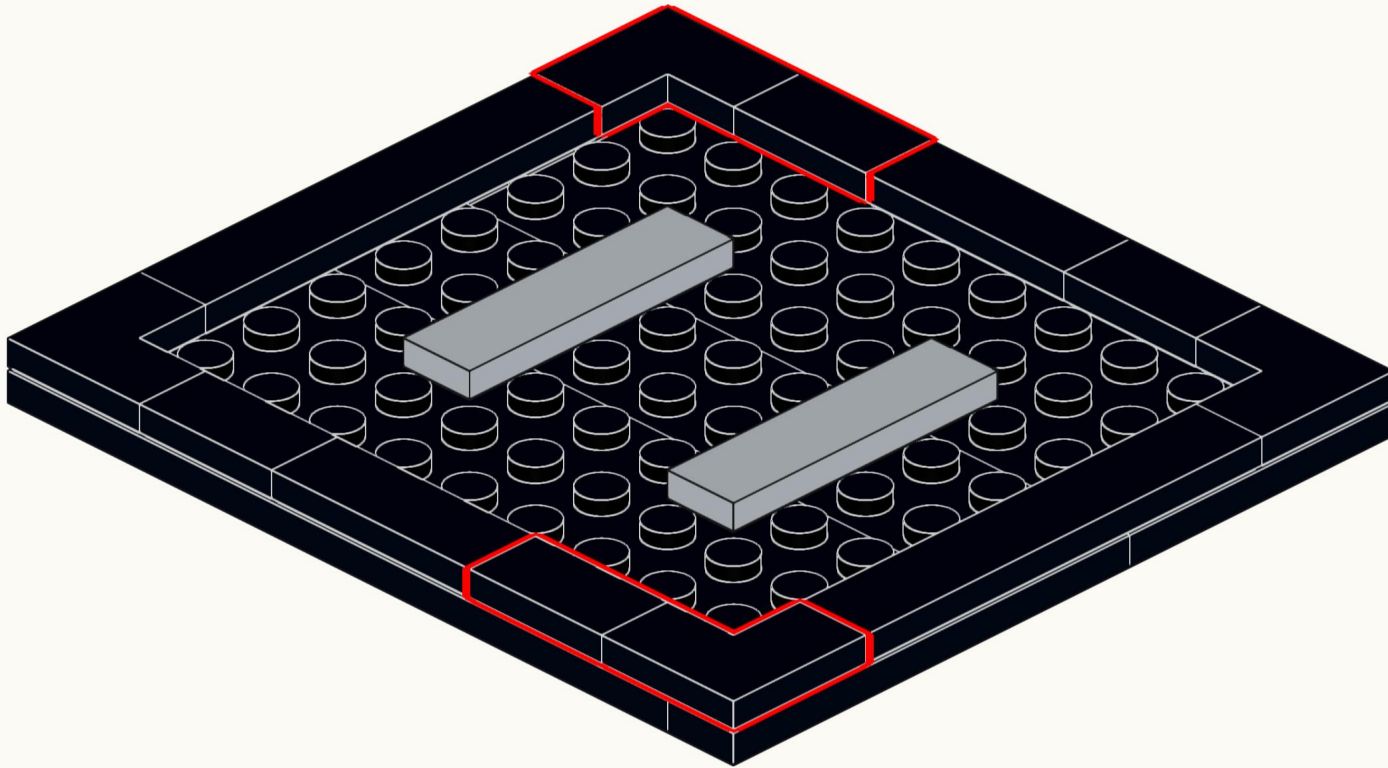

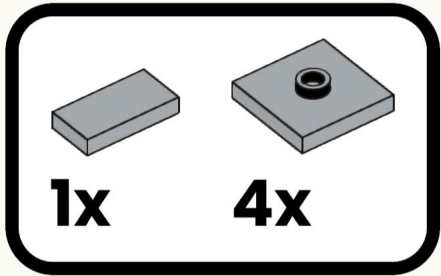

5

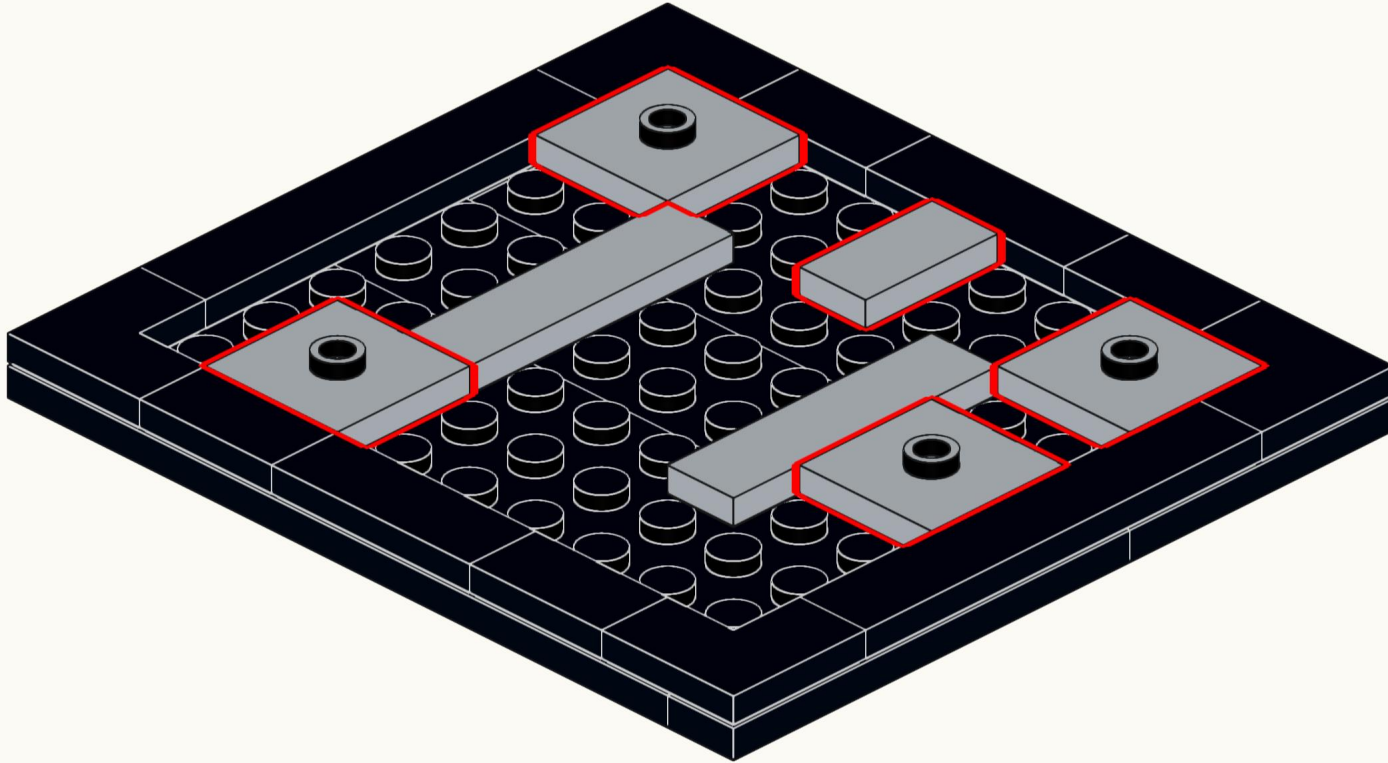

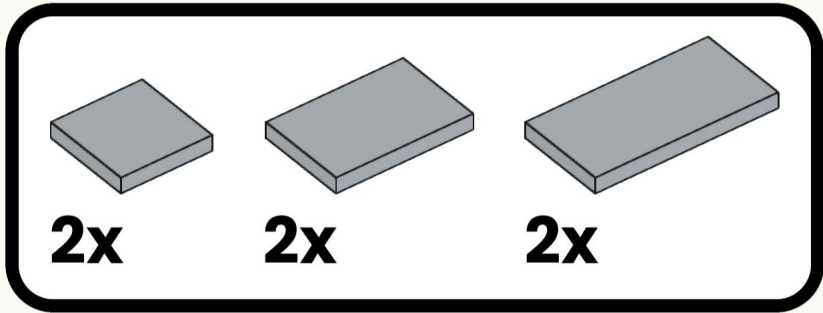

6

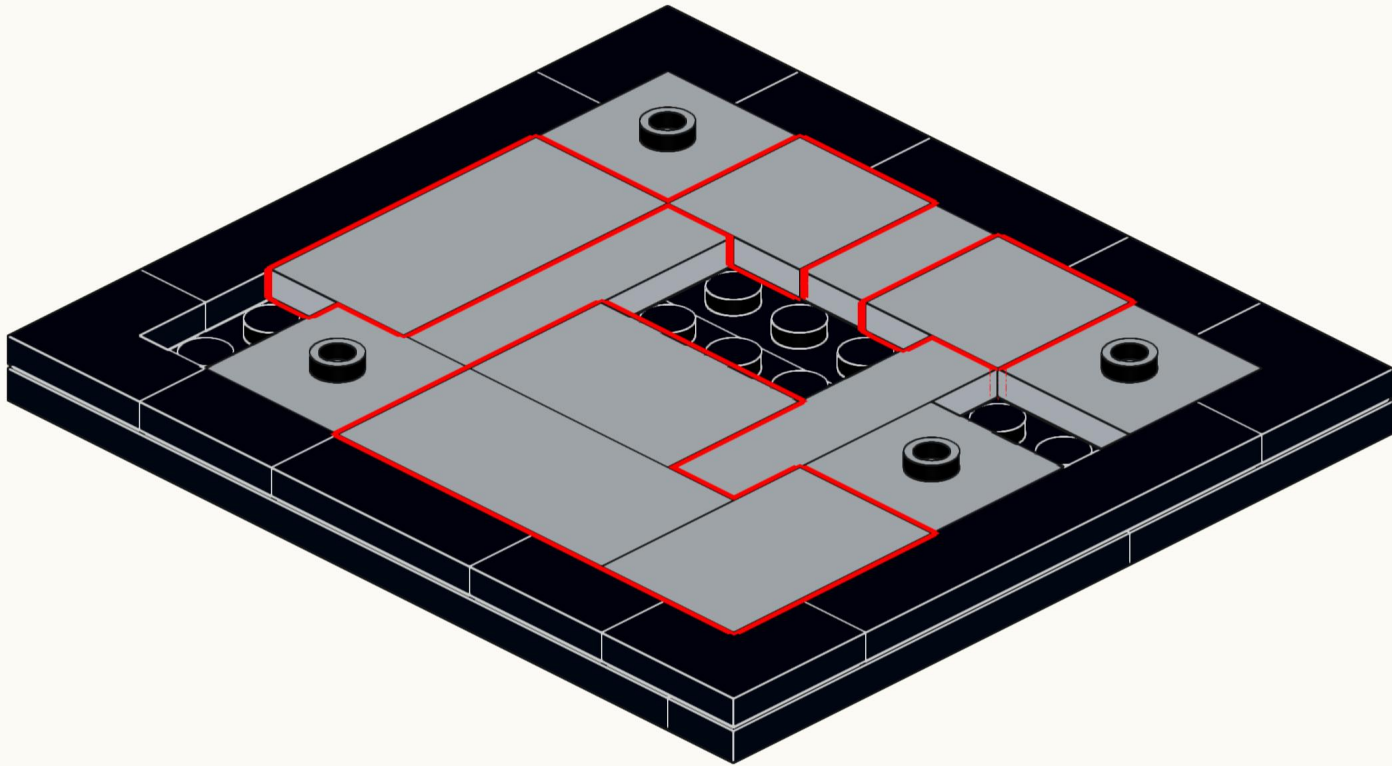

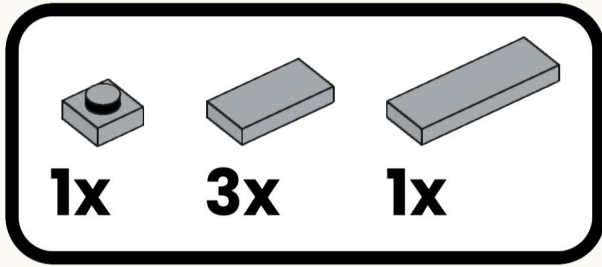

7

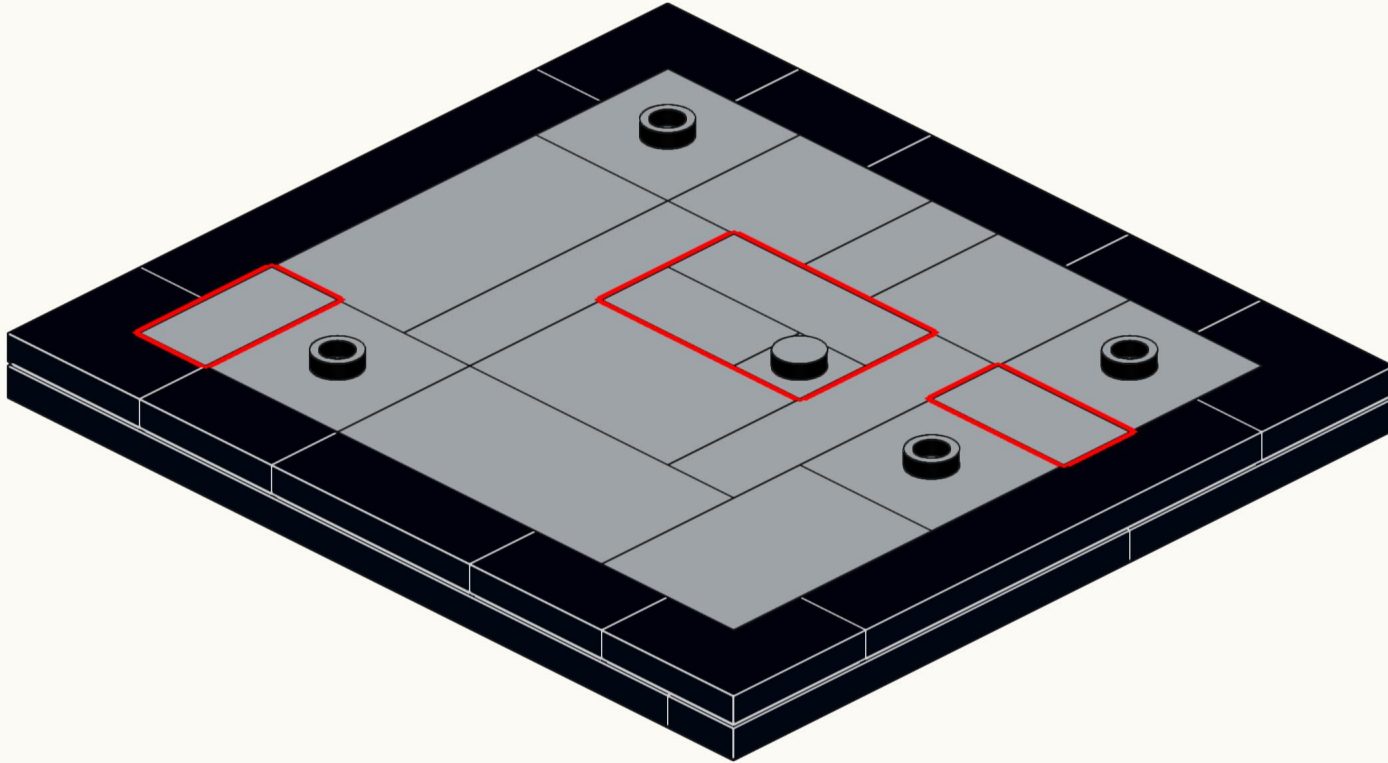



8

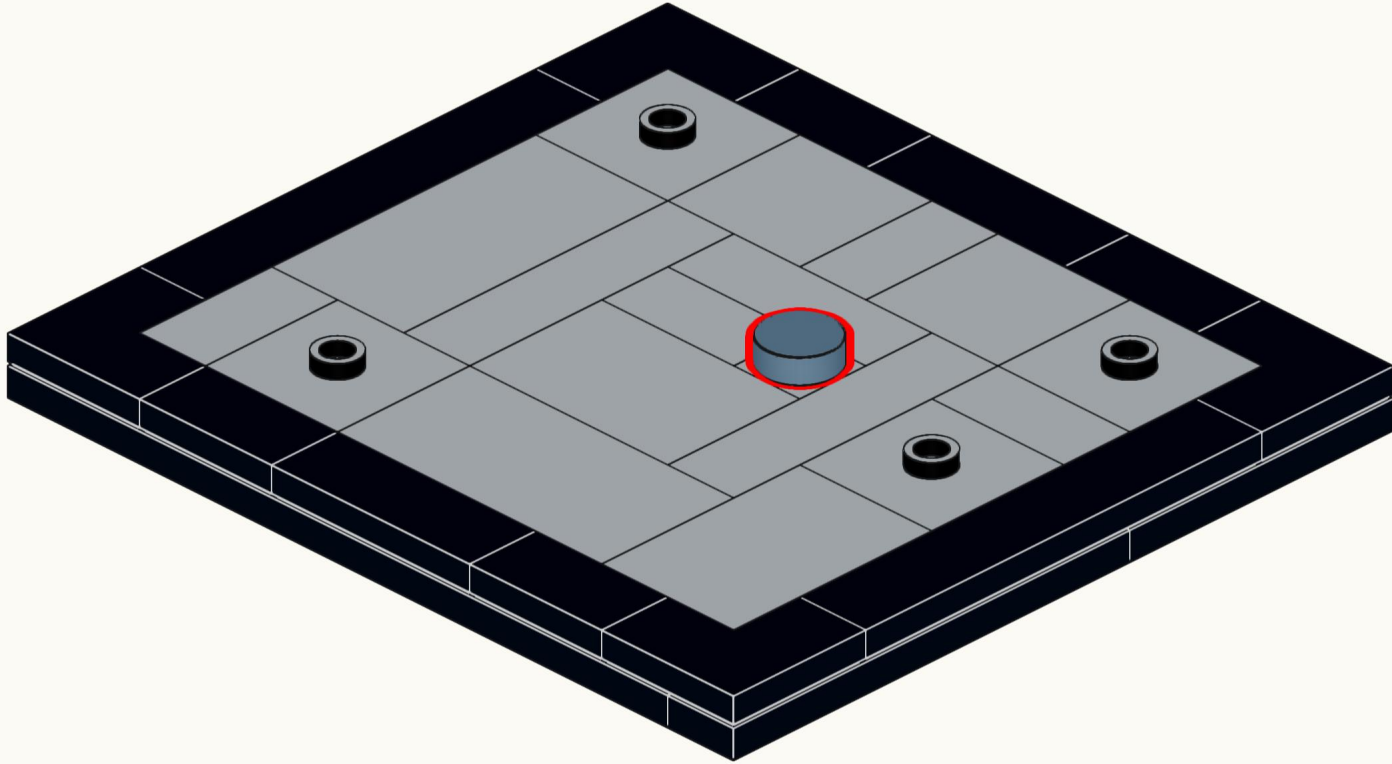

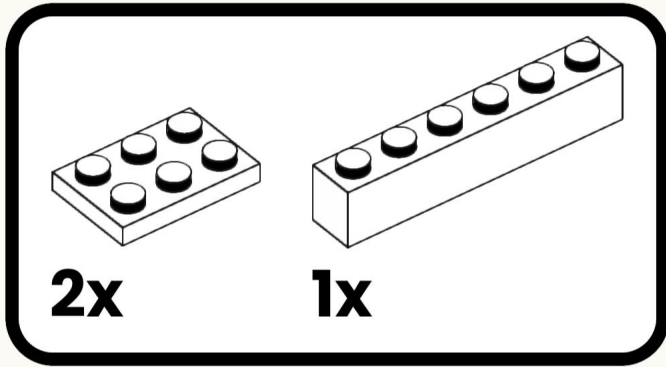

9

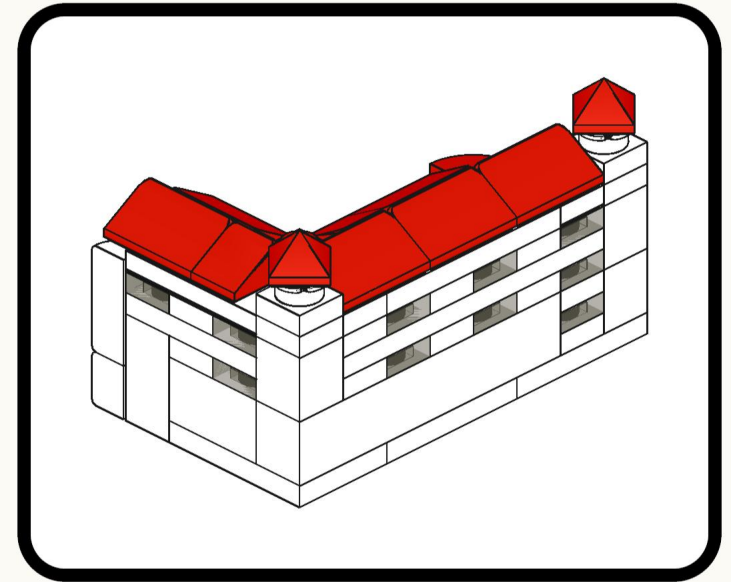
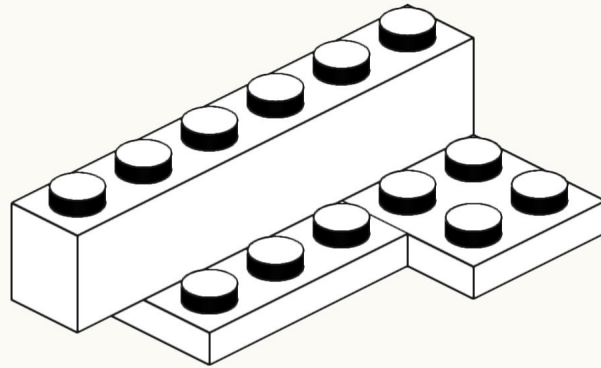

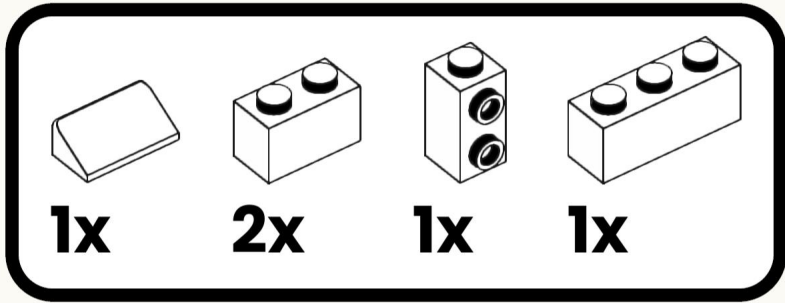

10

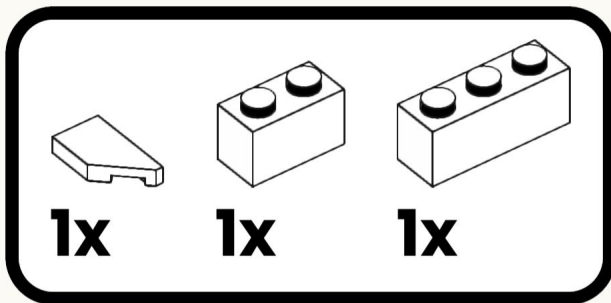
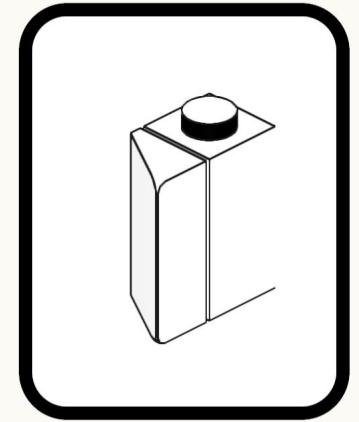
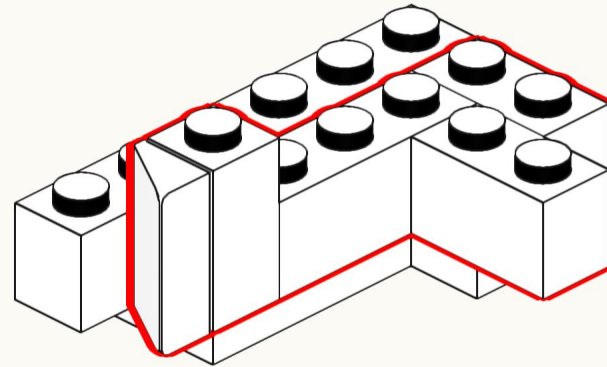

11

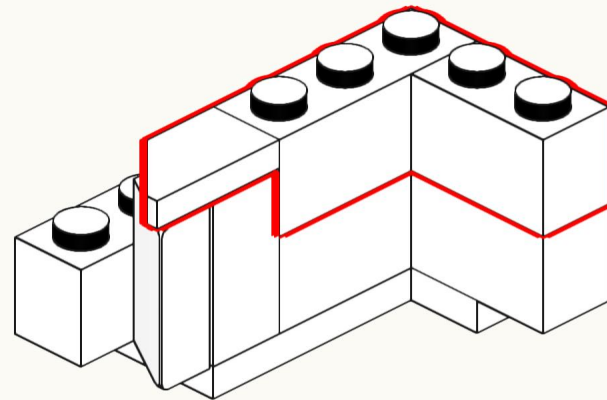

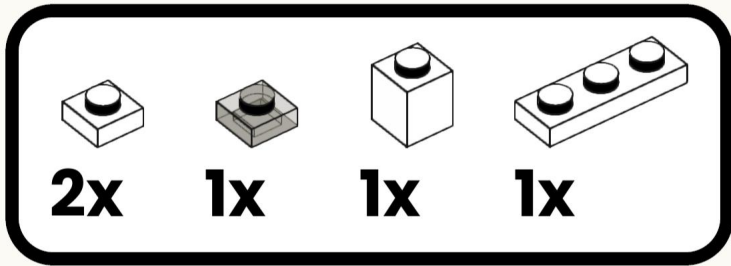

12

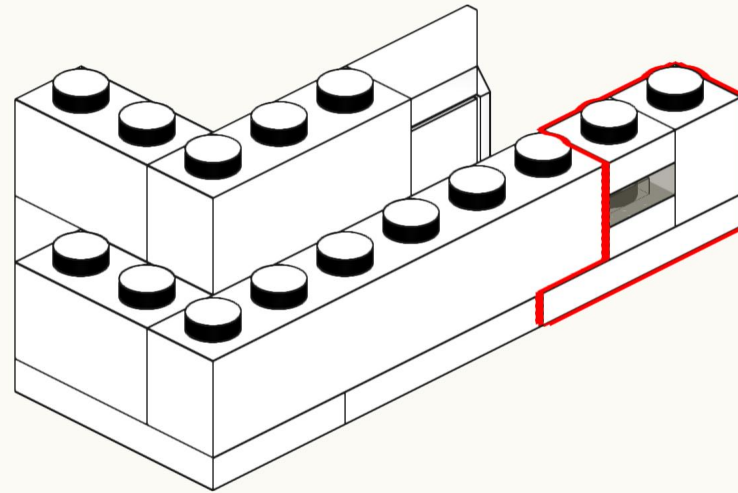

13

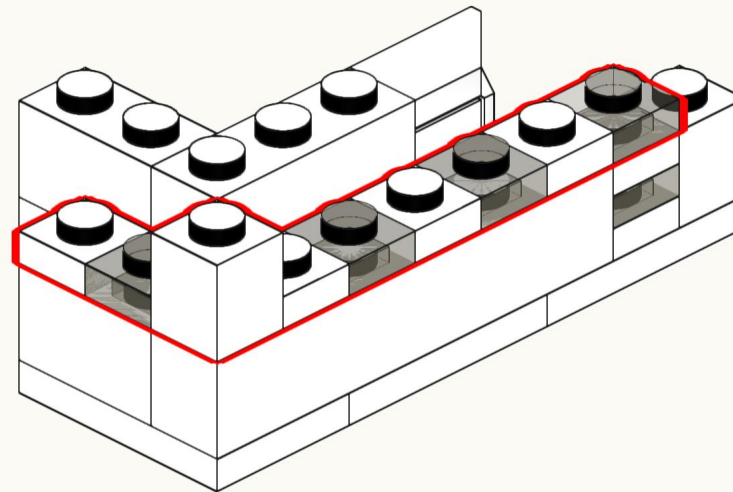
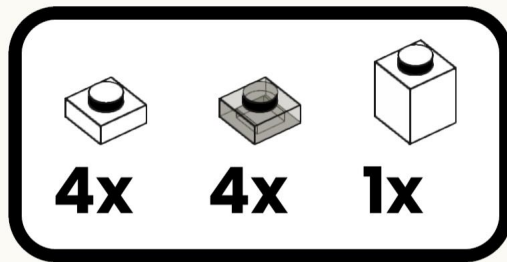

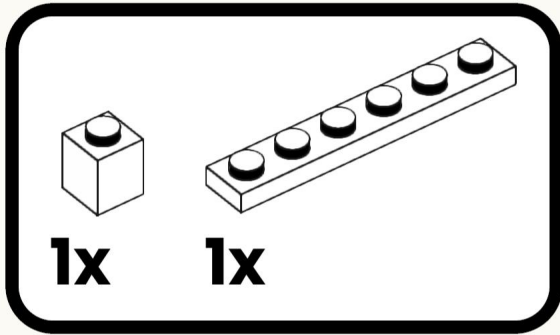

14

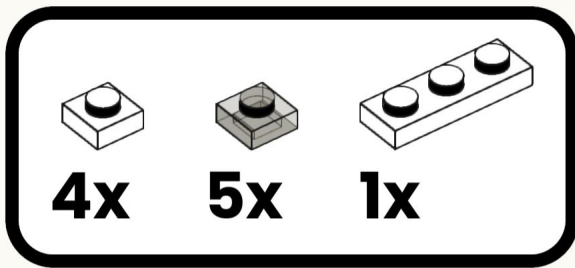
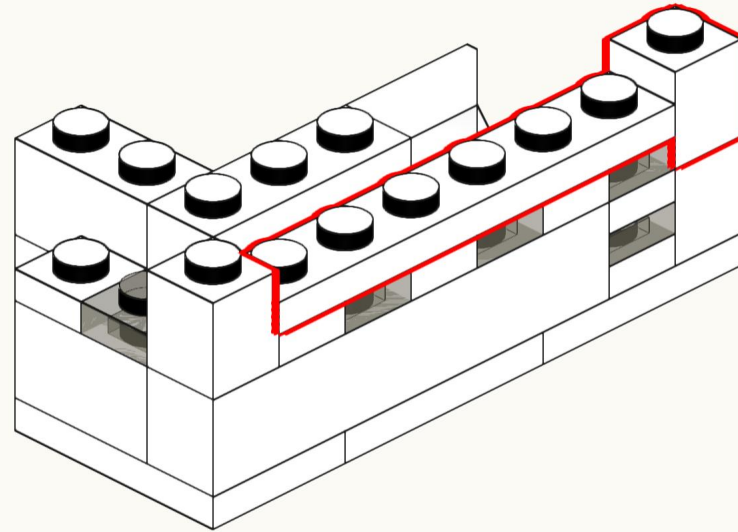

15

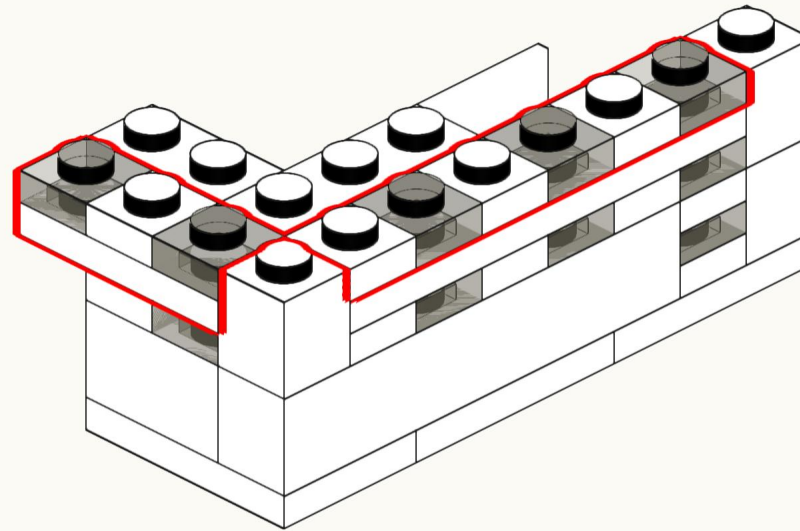

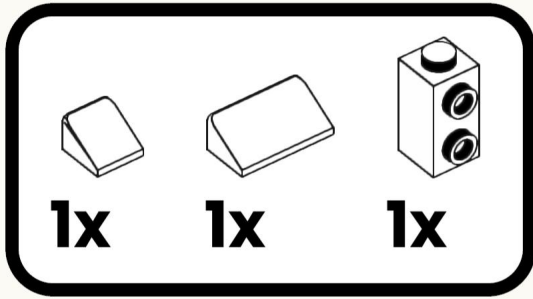

16

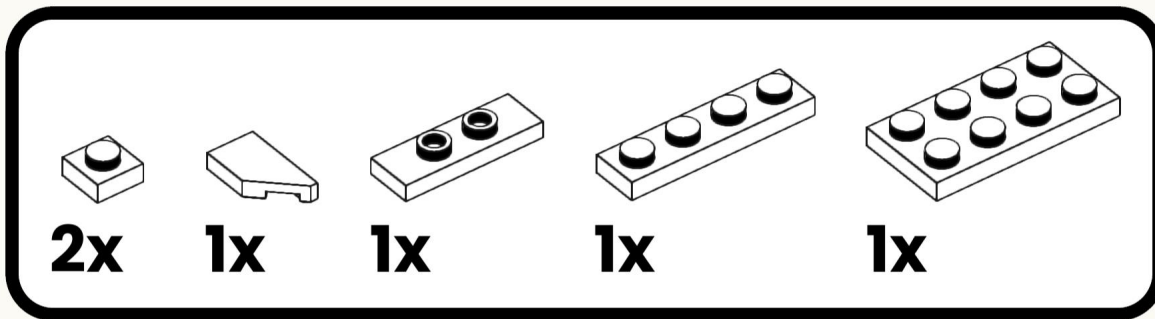
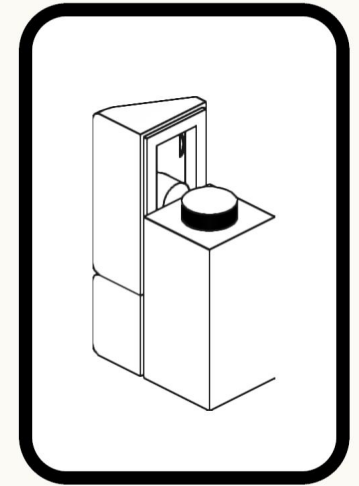
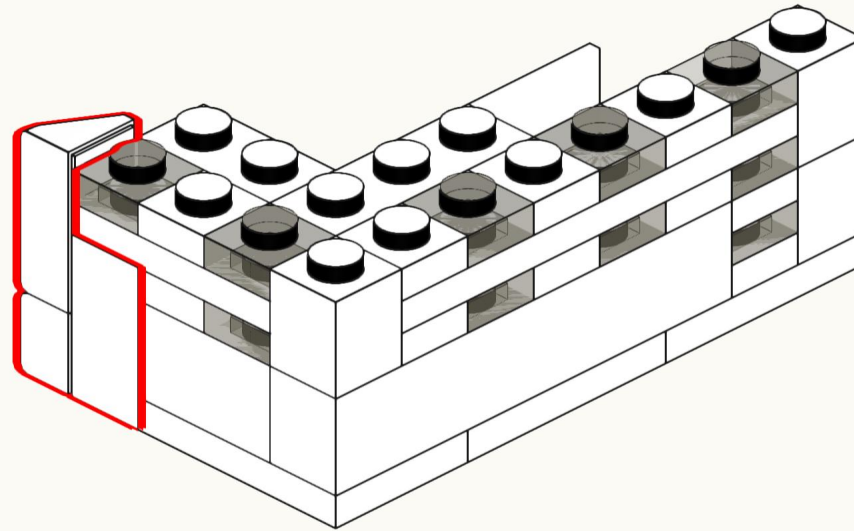

17

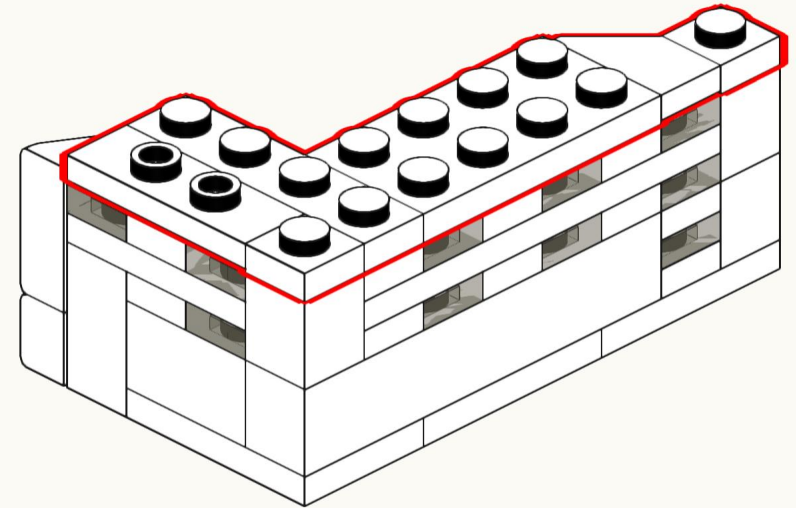

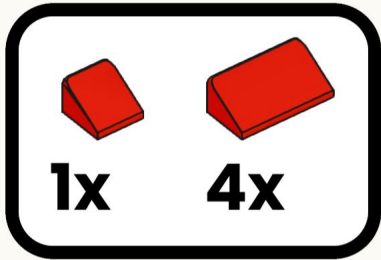

18

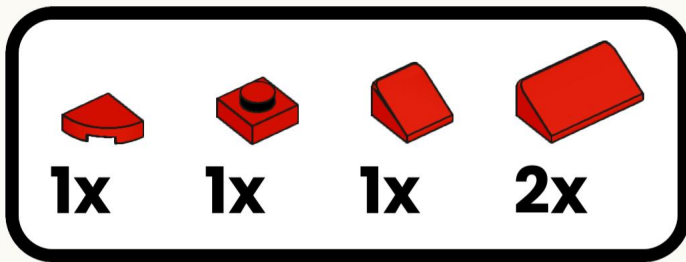
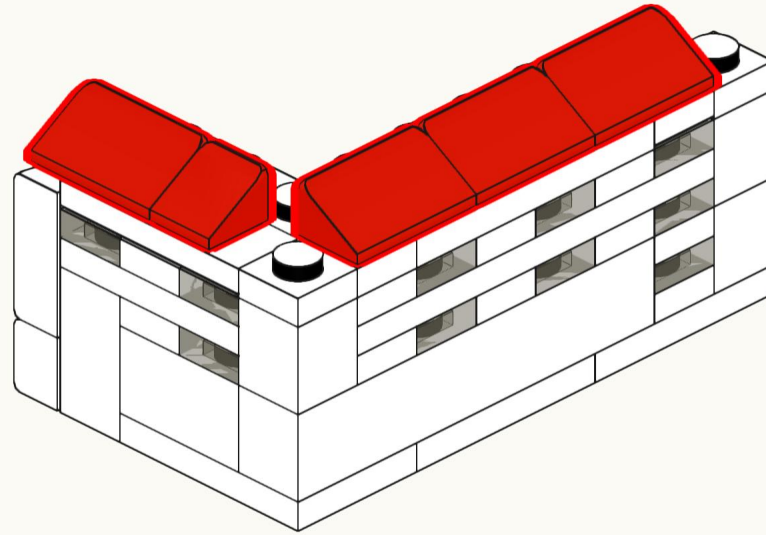

19

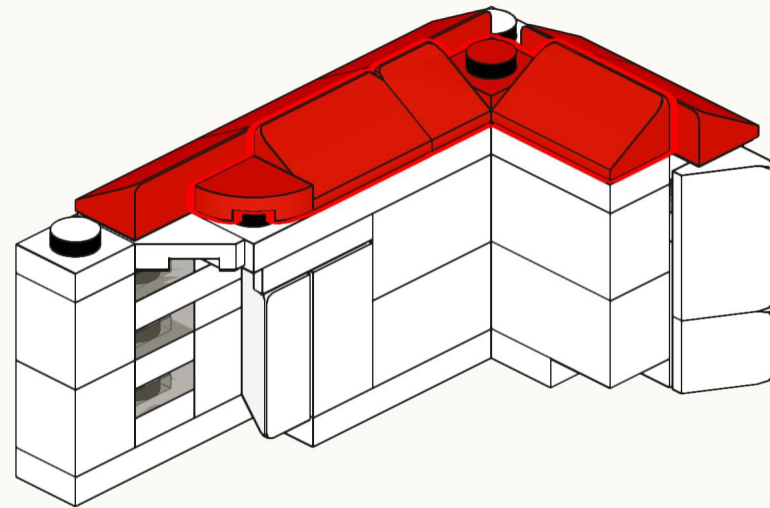

2x 2x 2x

20

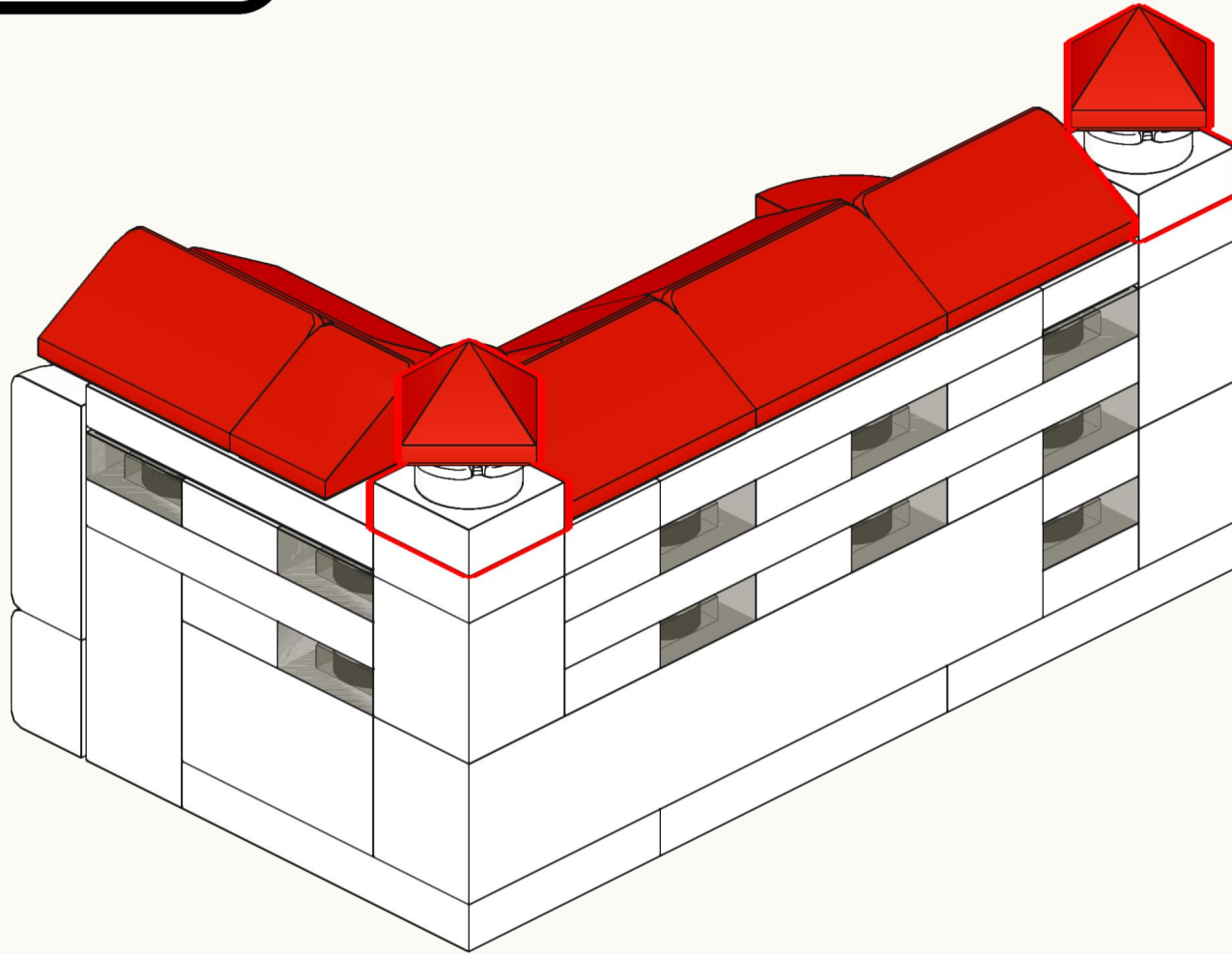

2x

A detailed inset diagram showing a red pyramid being placed on top of a white Technic base. The text "2x" is written above the diagram, indicating that two of these sub-assemblies are required for the step.

21

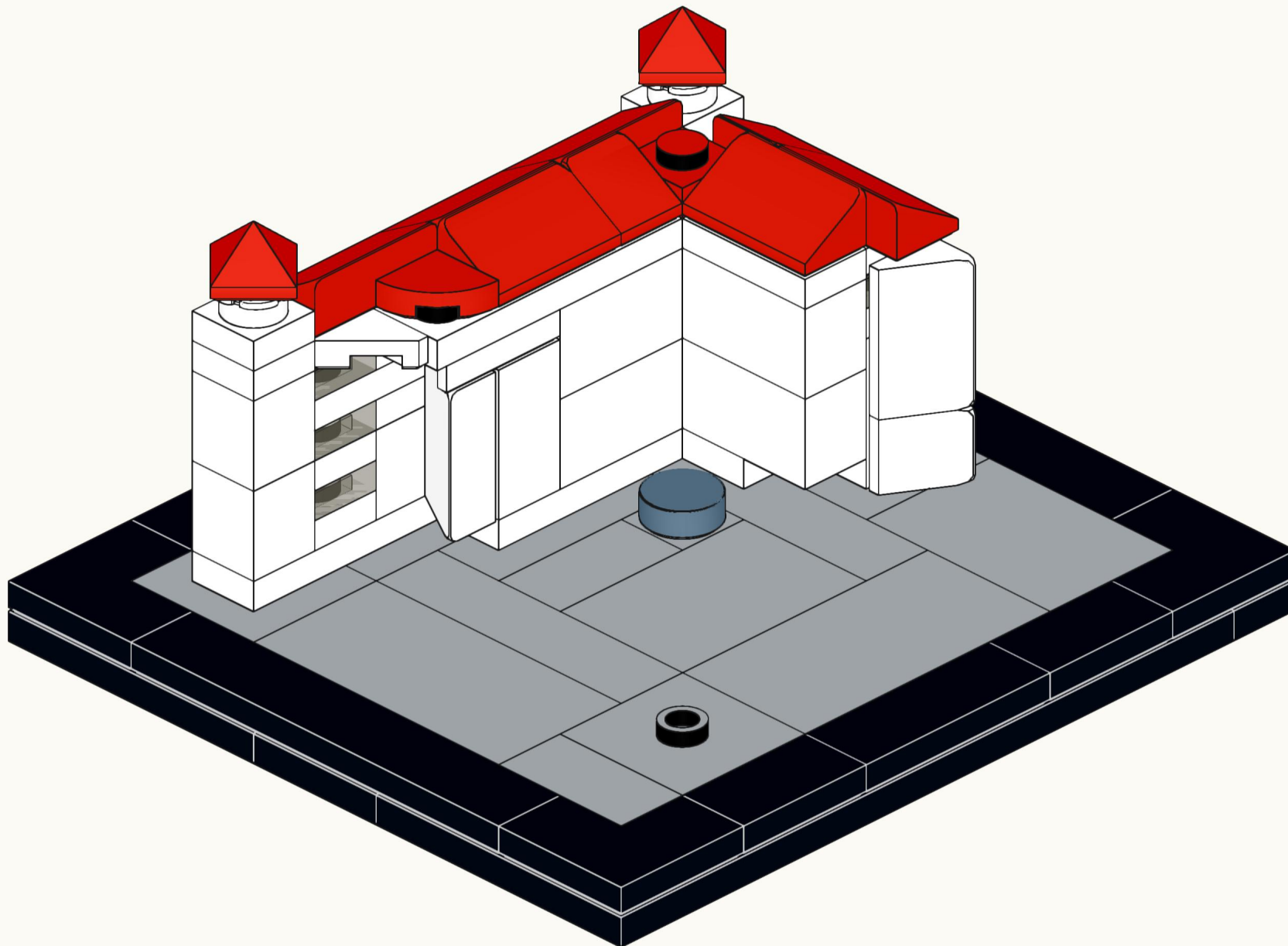

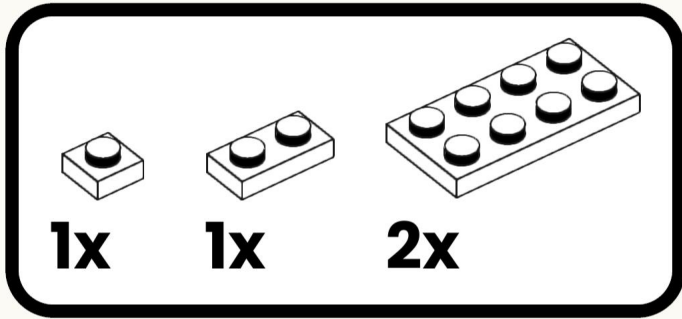

22

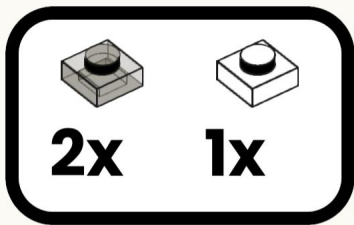
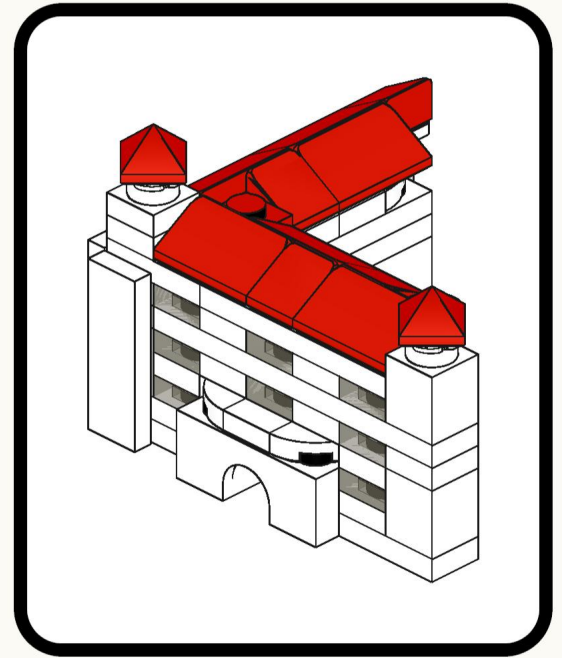
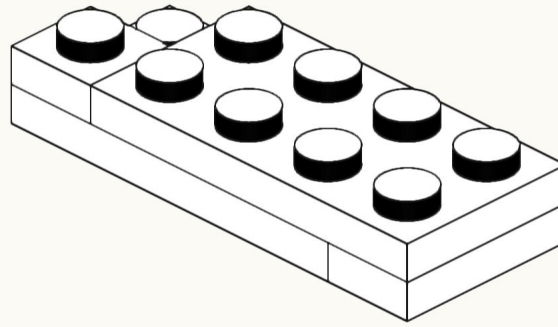

23

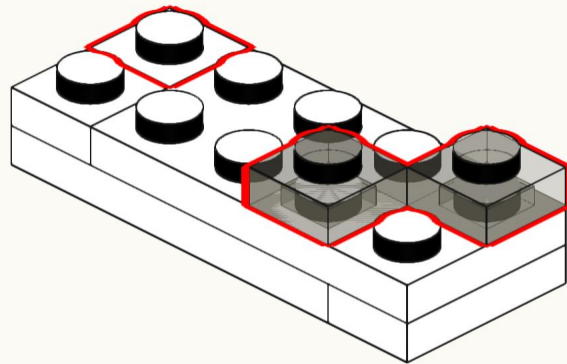

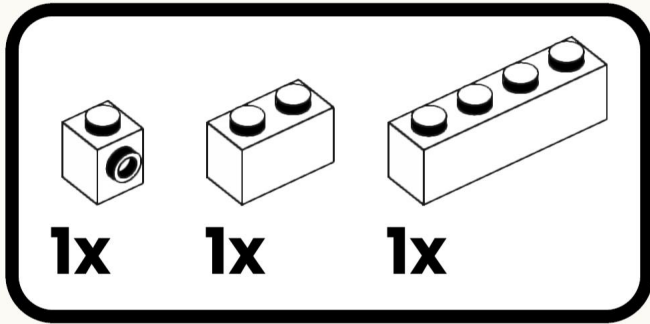

24

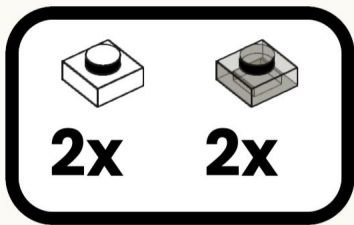
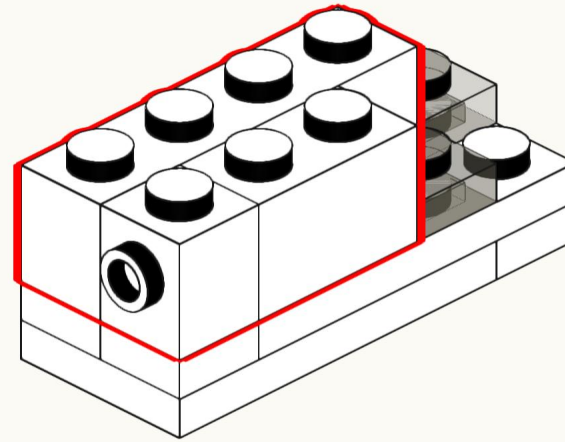

25

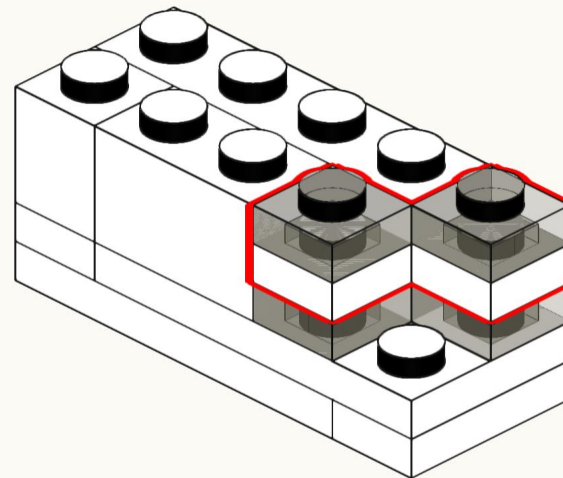

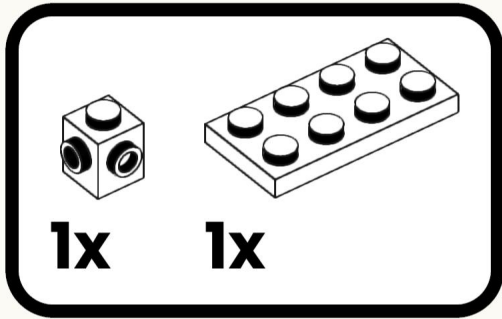

26

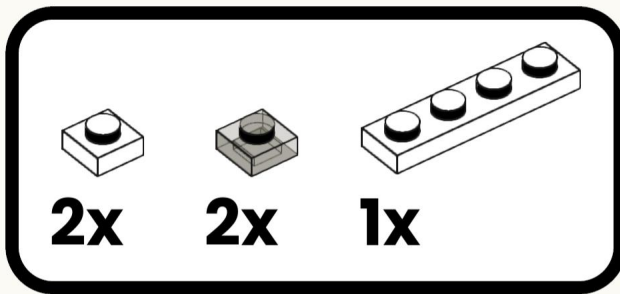
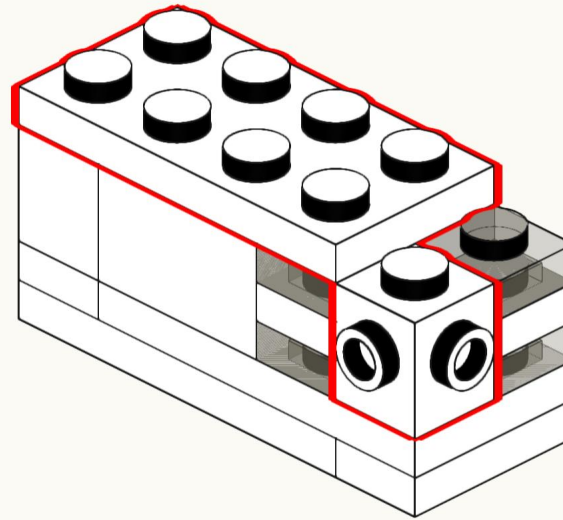

27

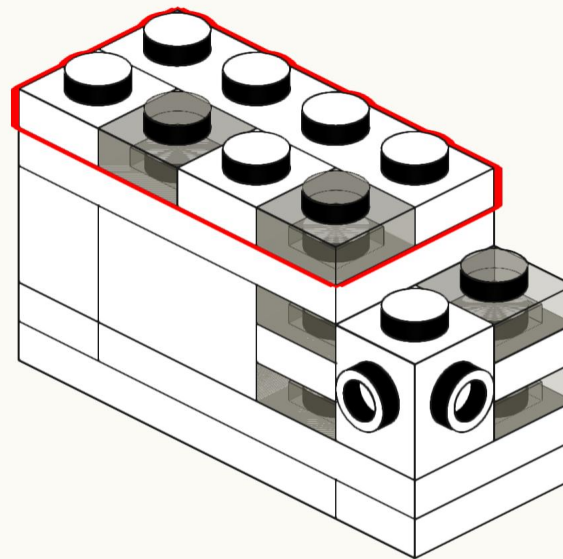

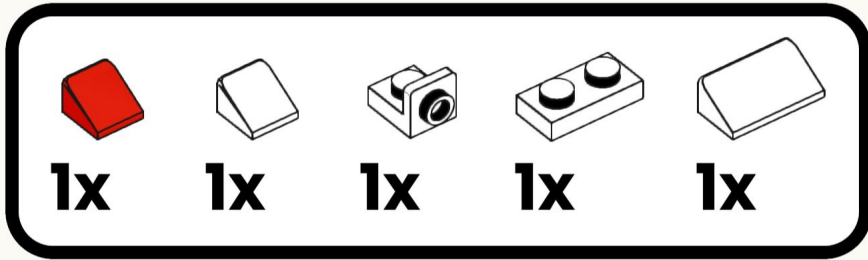

28

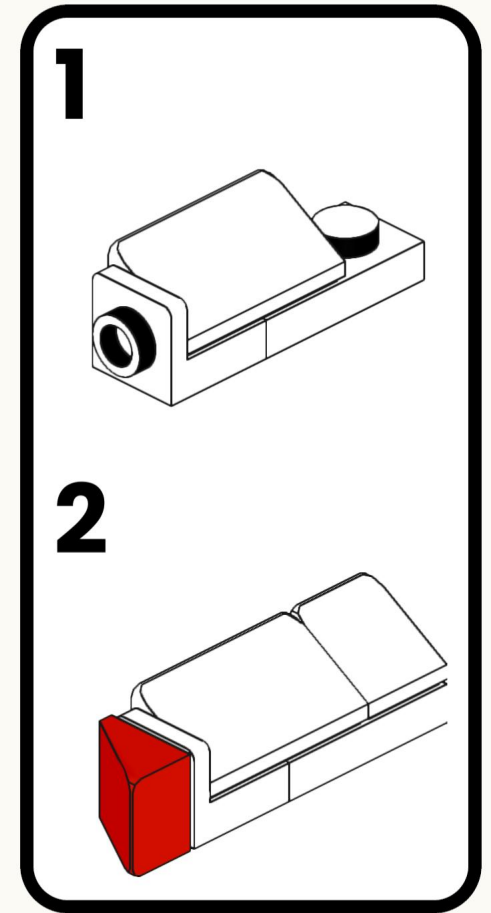
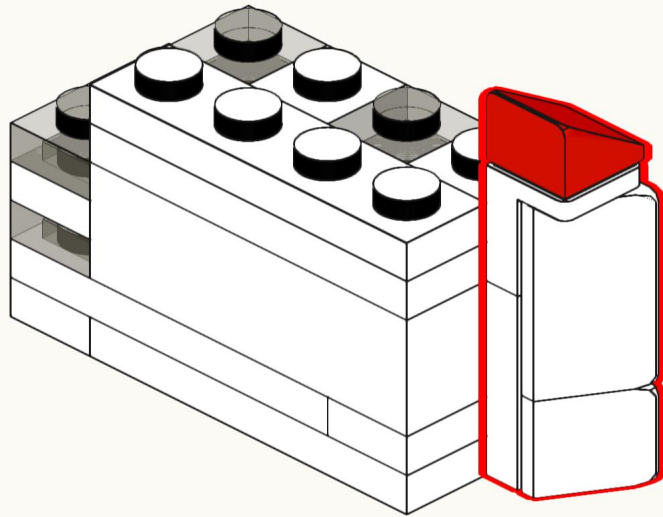

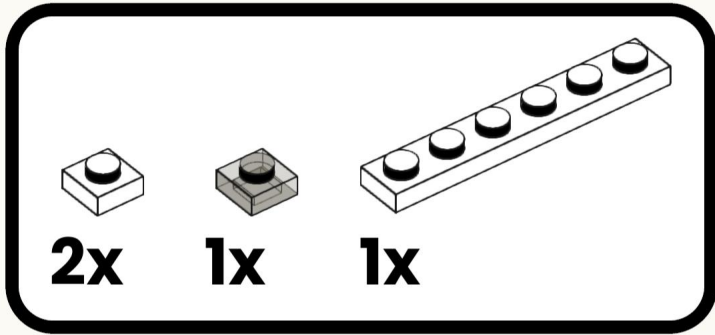

29

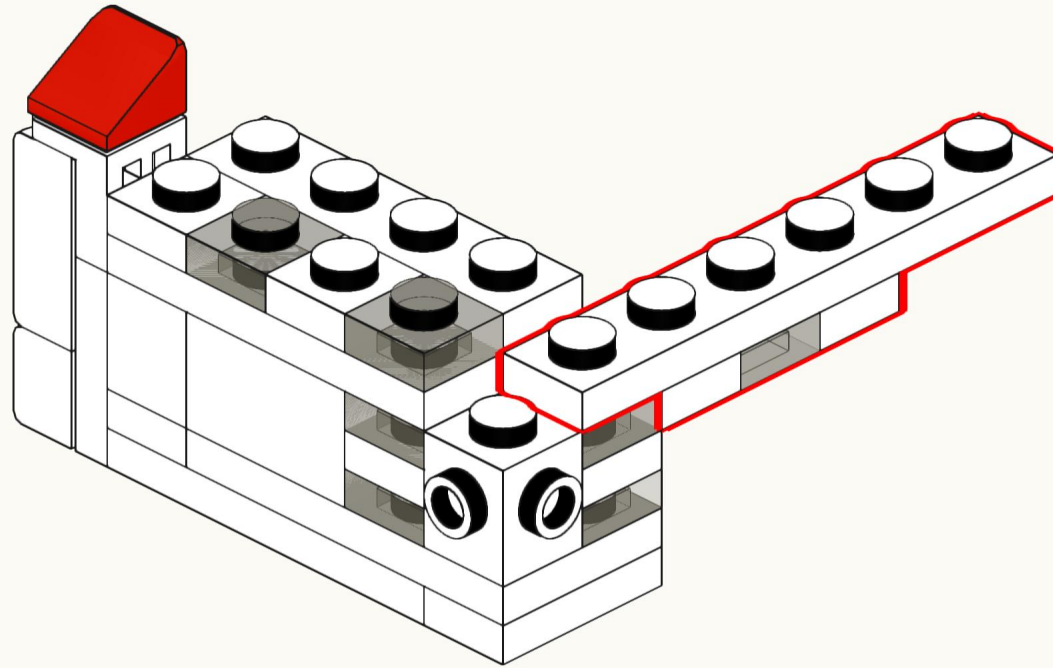

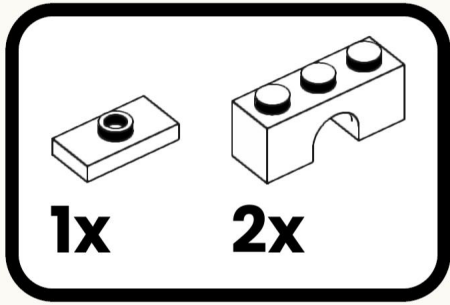

30

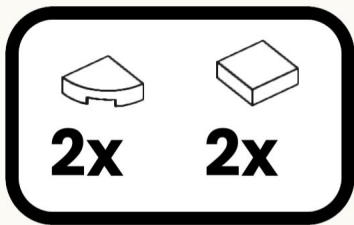
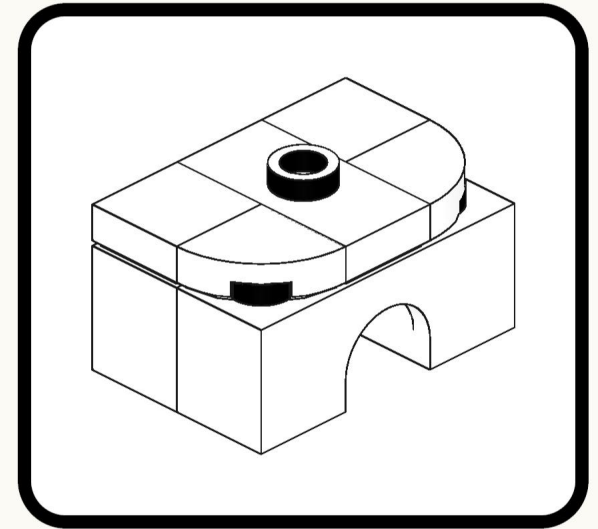
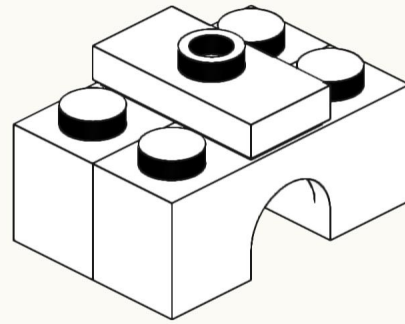

31

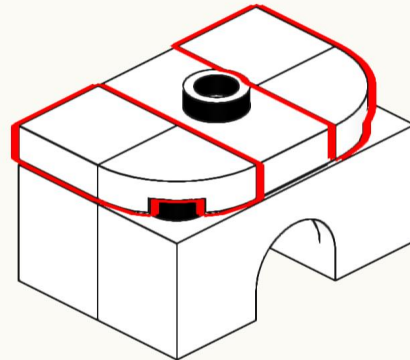

32

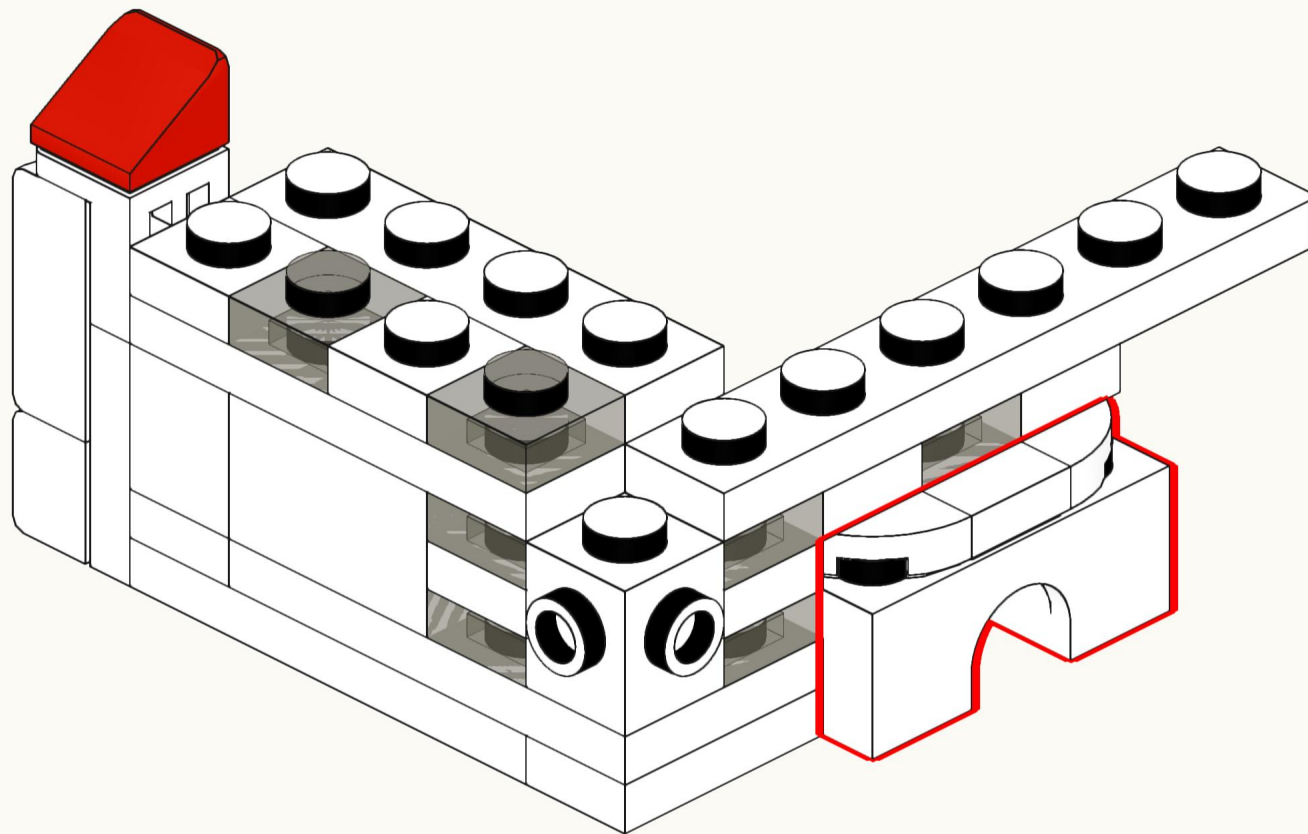

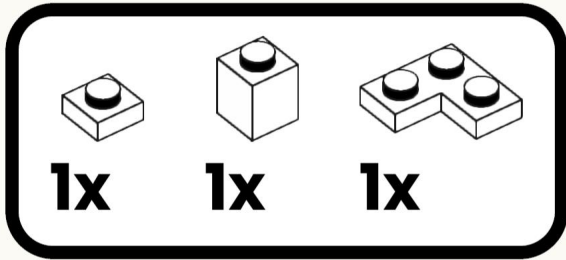

33

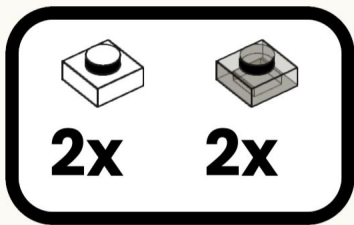
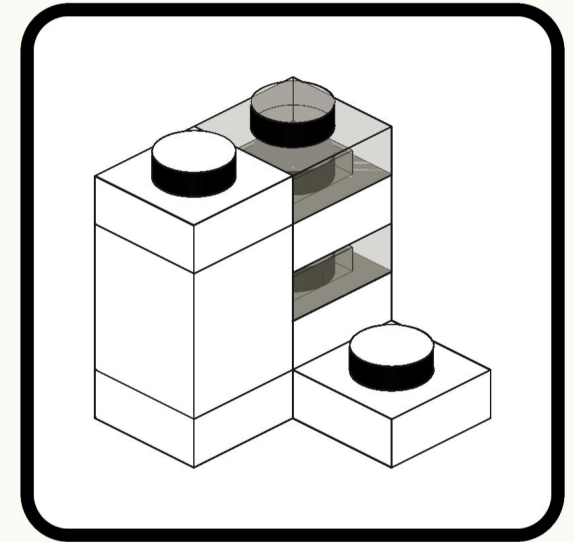
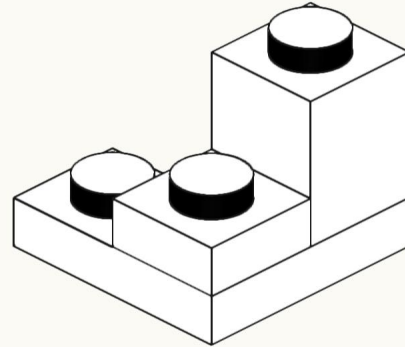

34

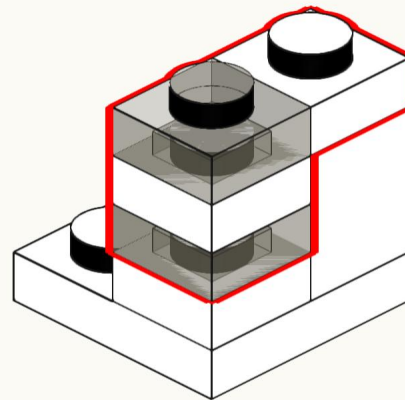

35

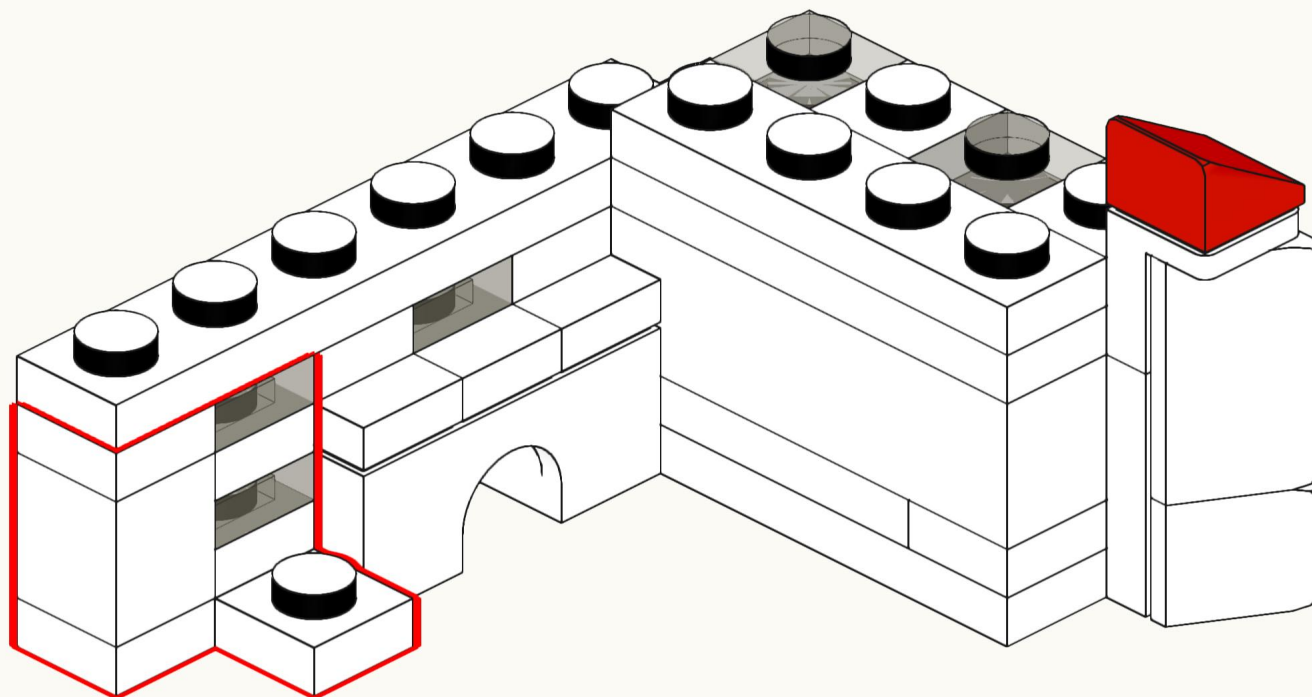

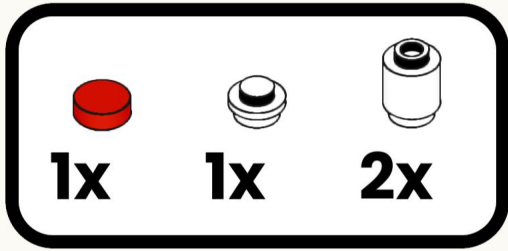

36

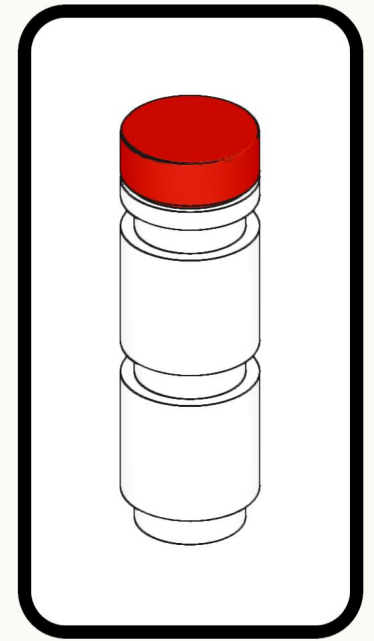
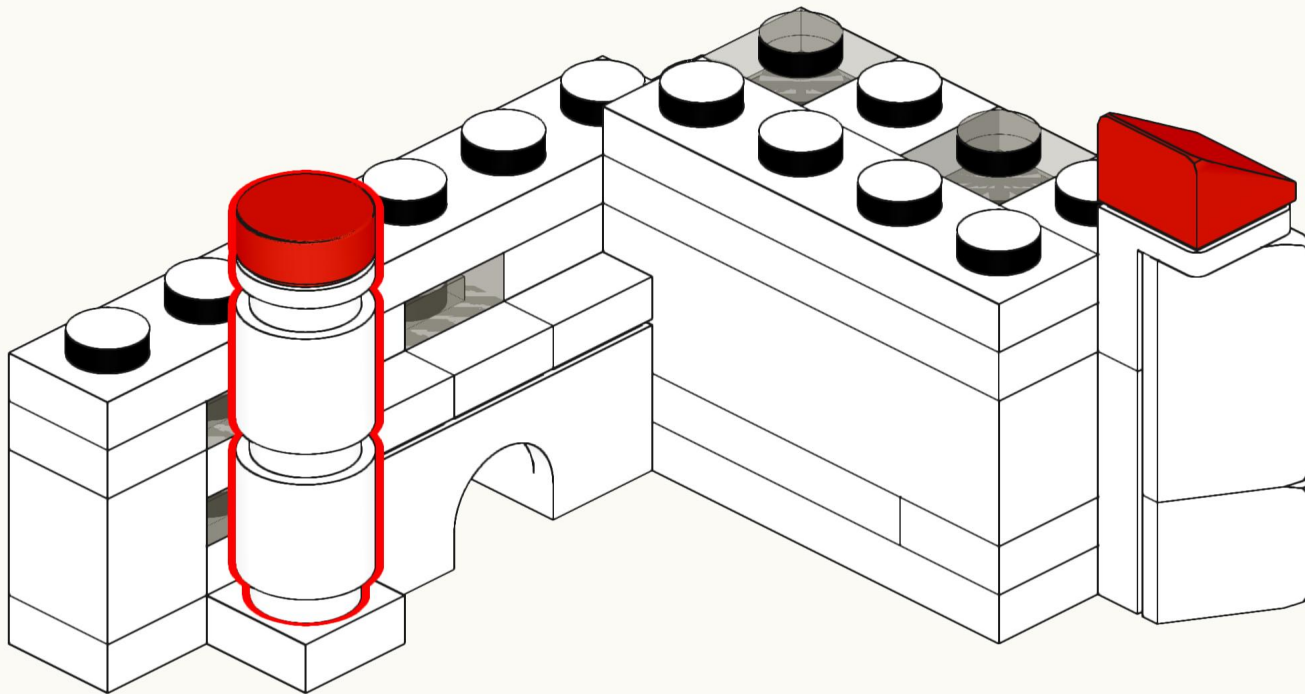

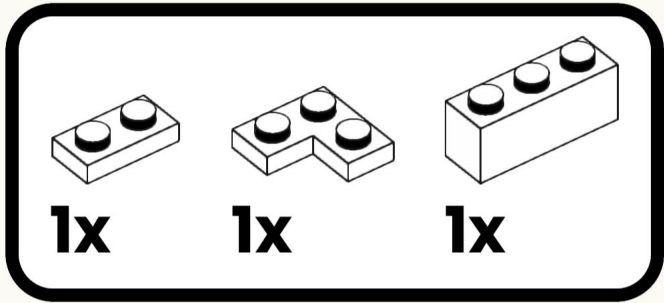

37

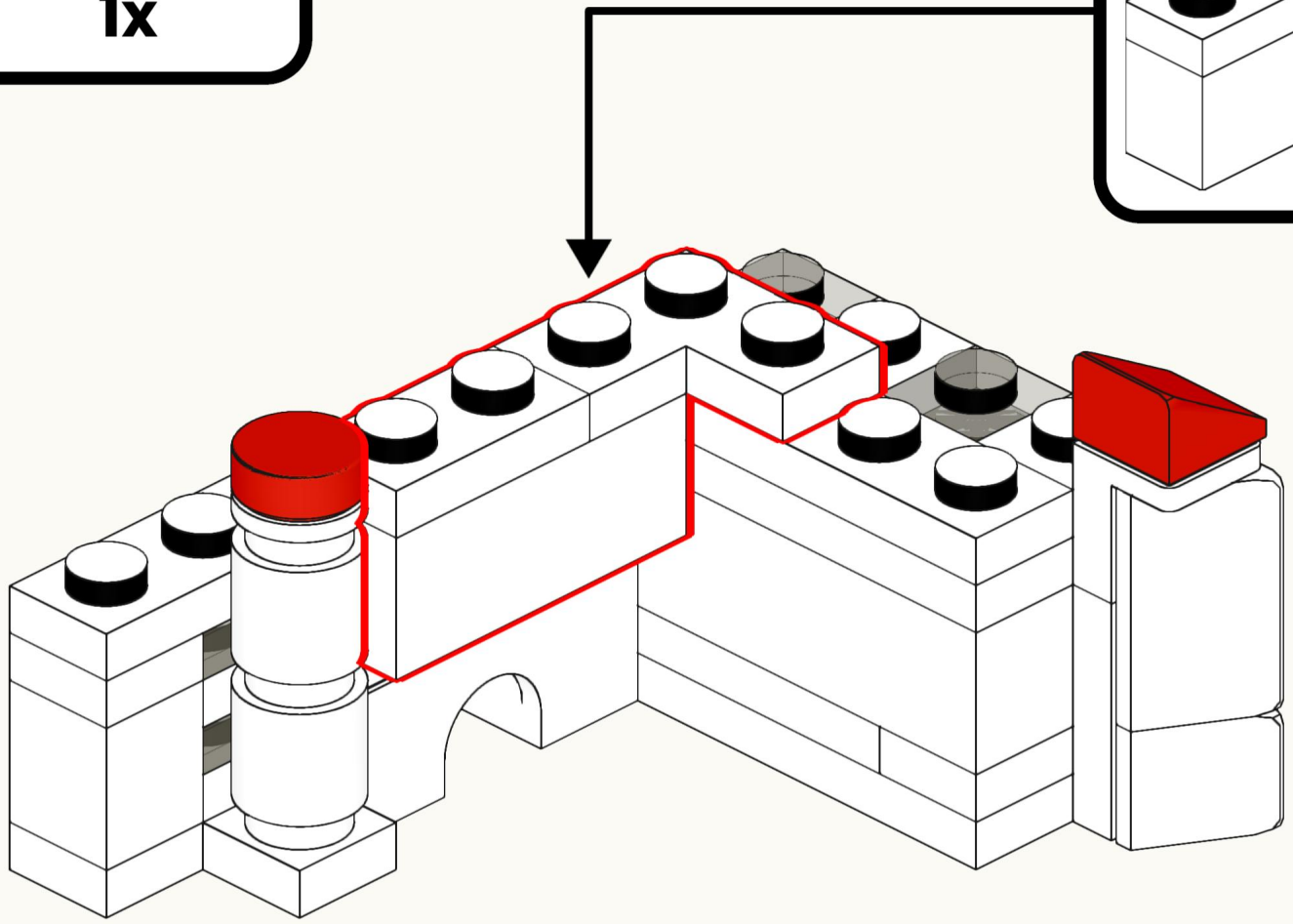
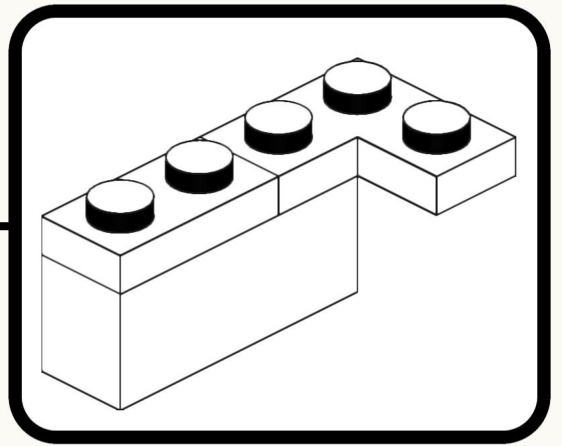

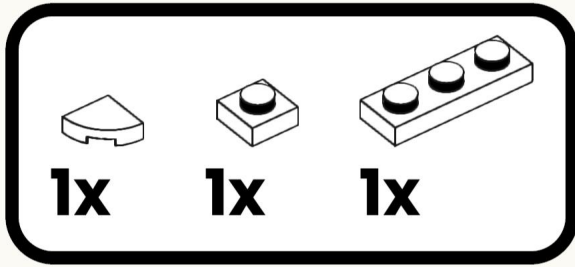

38

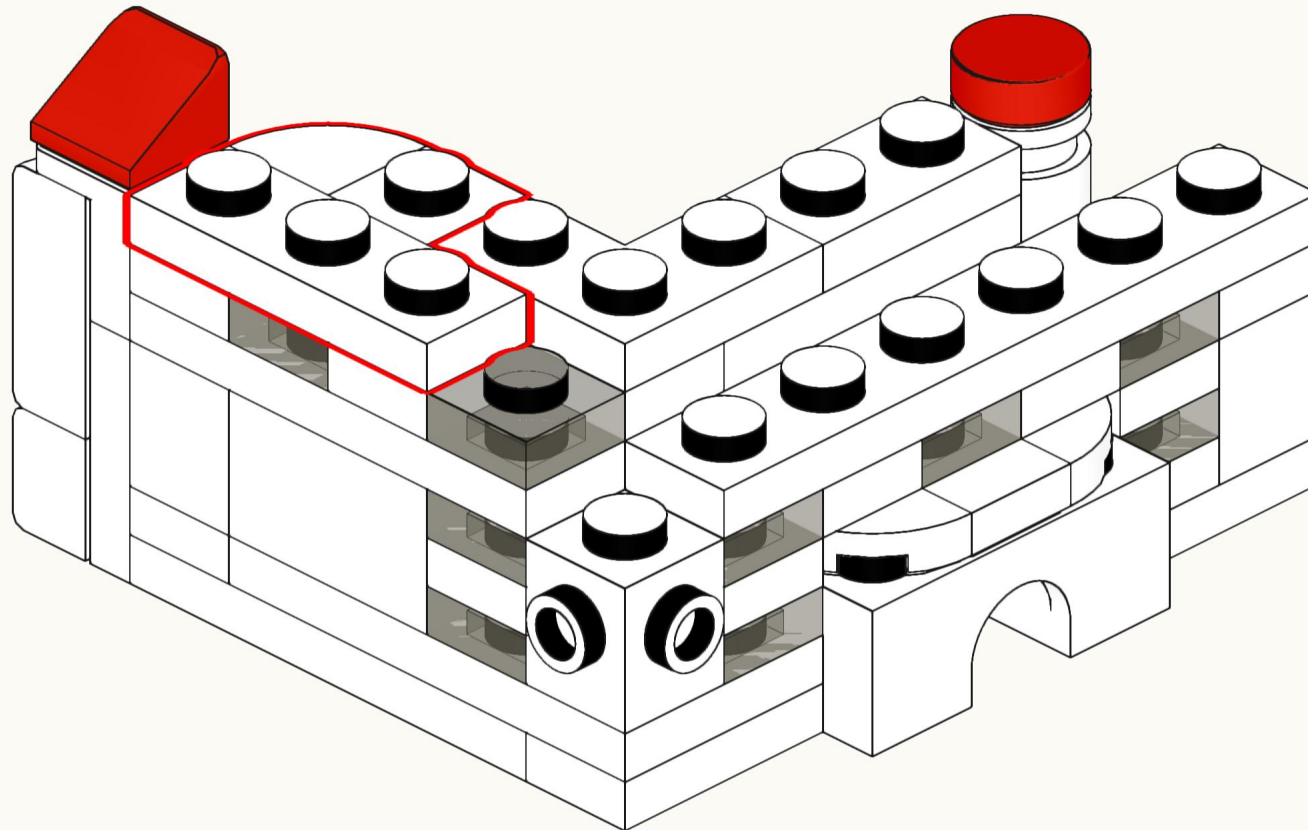

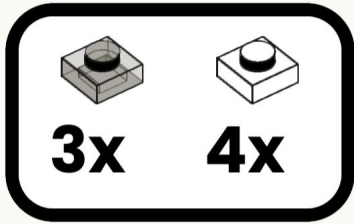

39

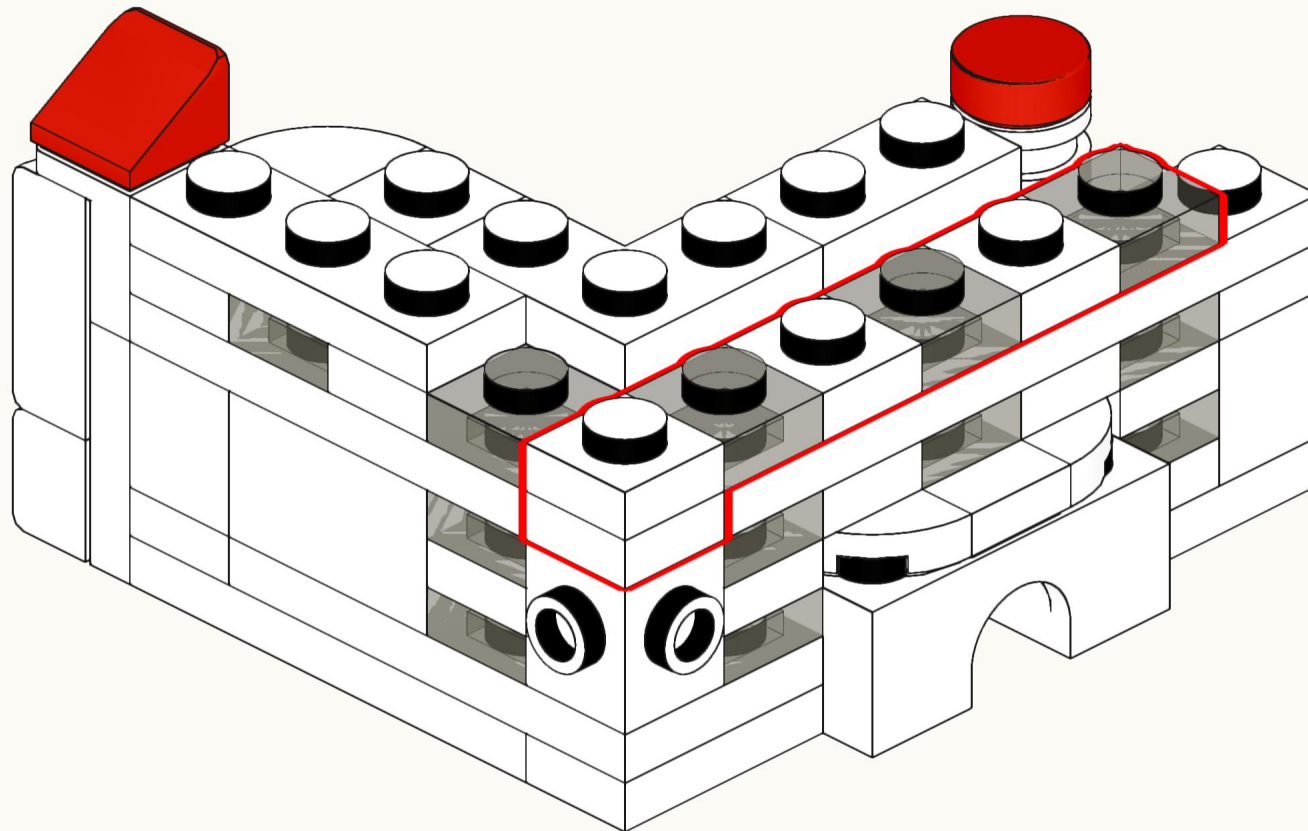

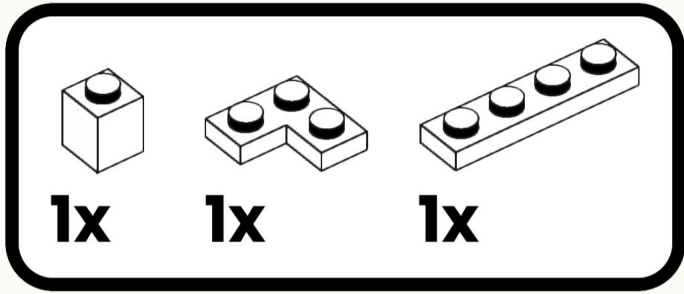

40

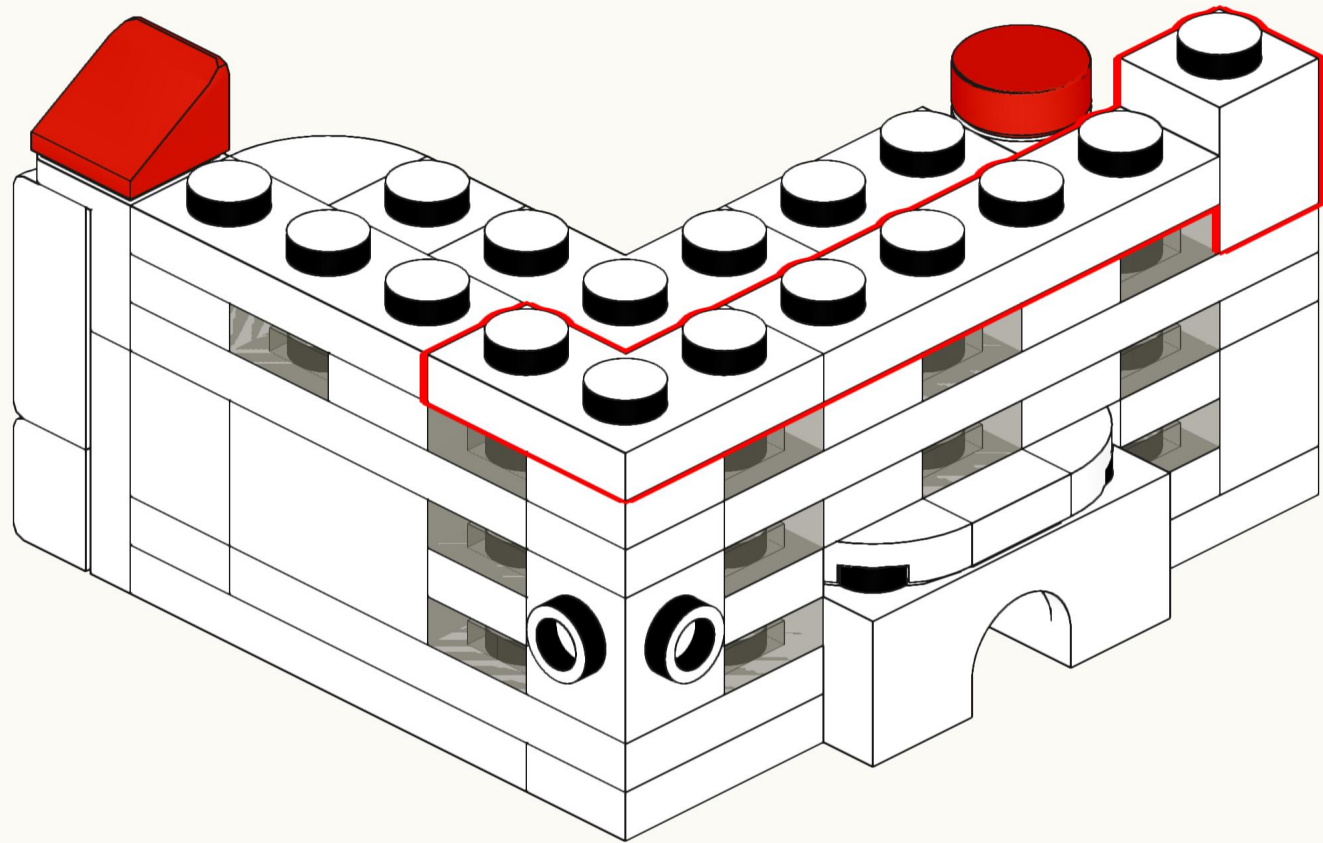

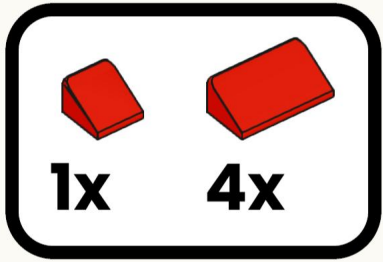

41

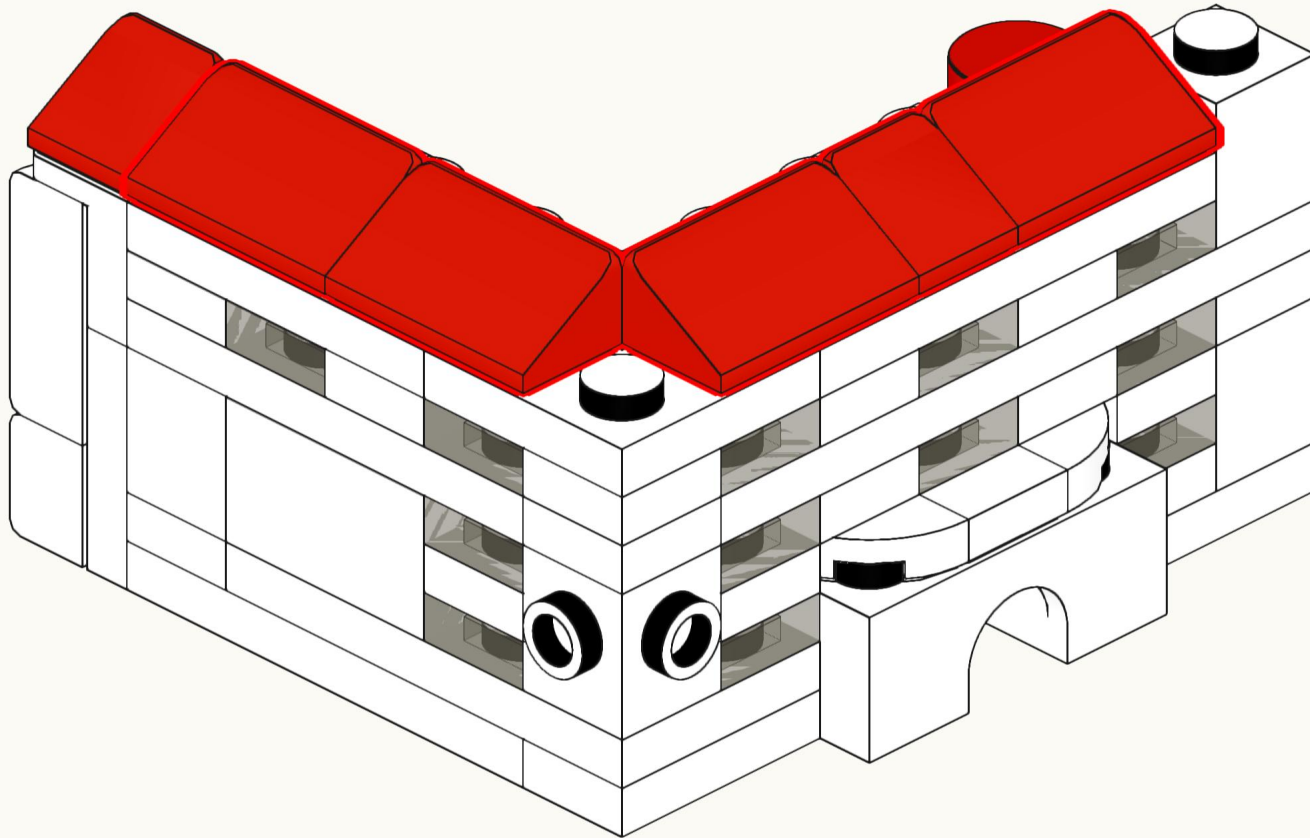

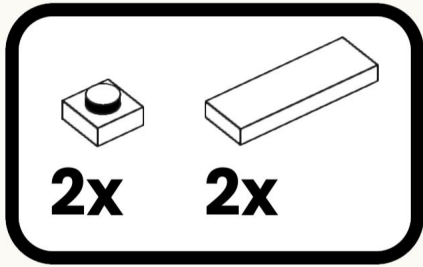

42

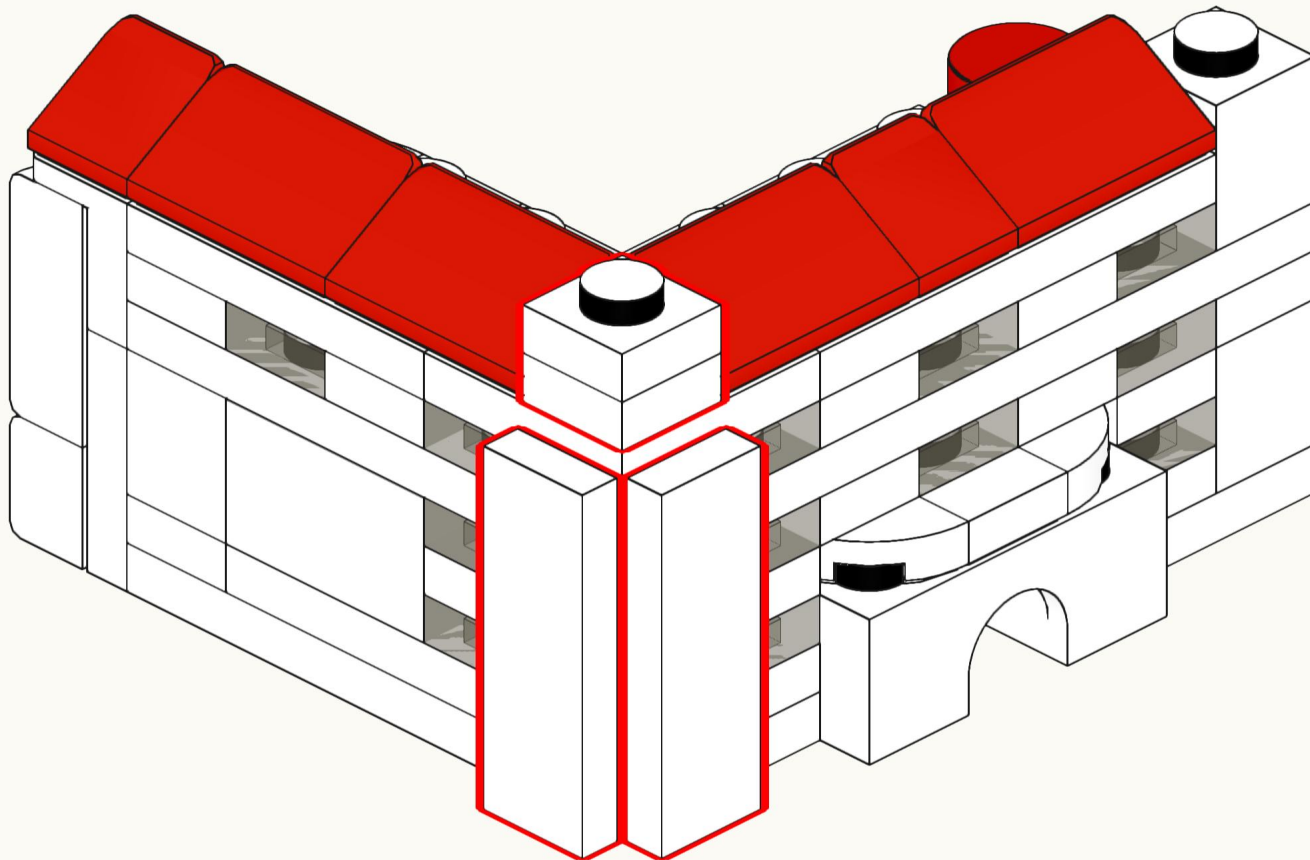

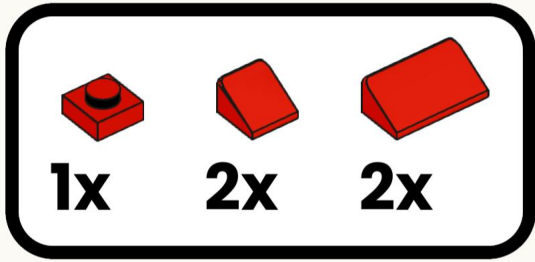

43

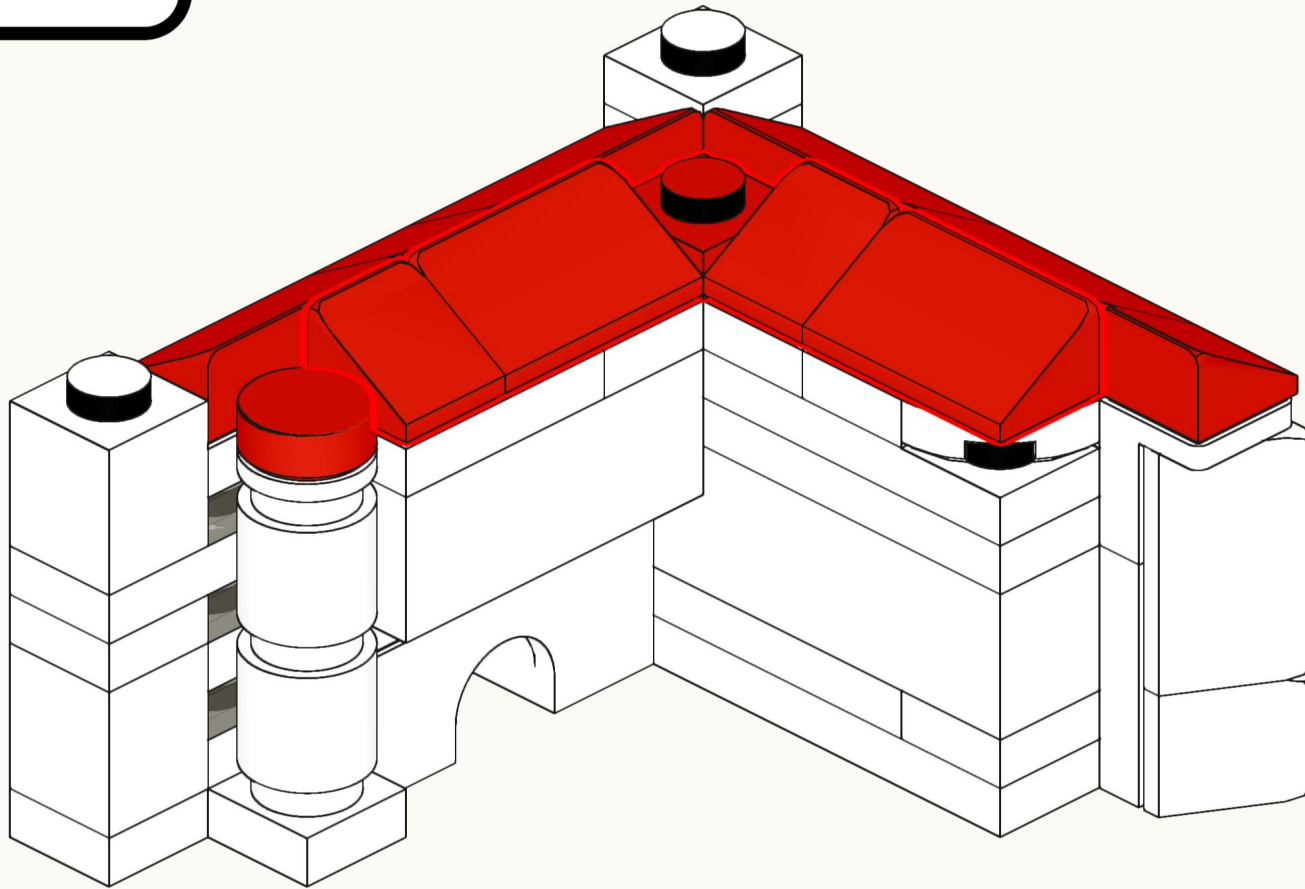

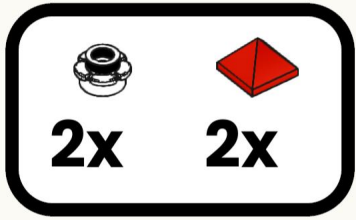

44

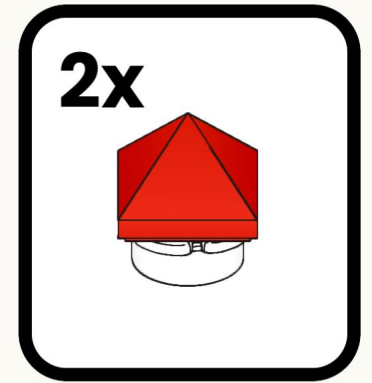
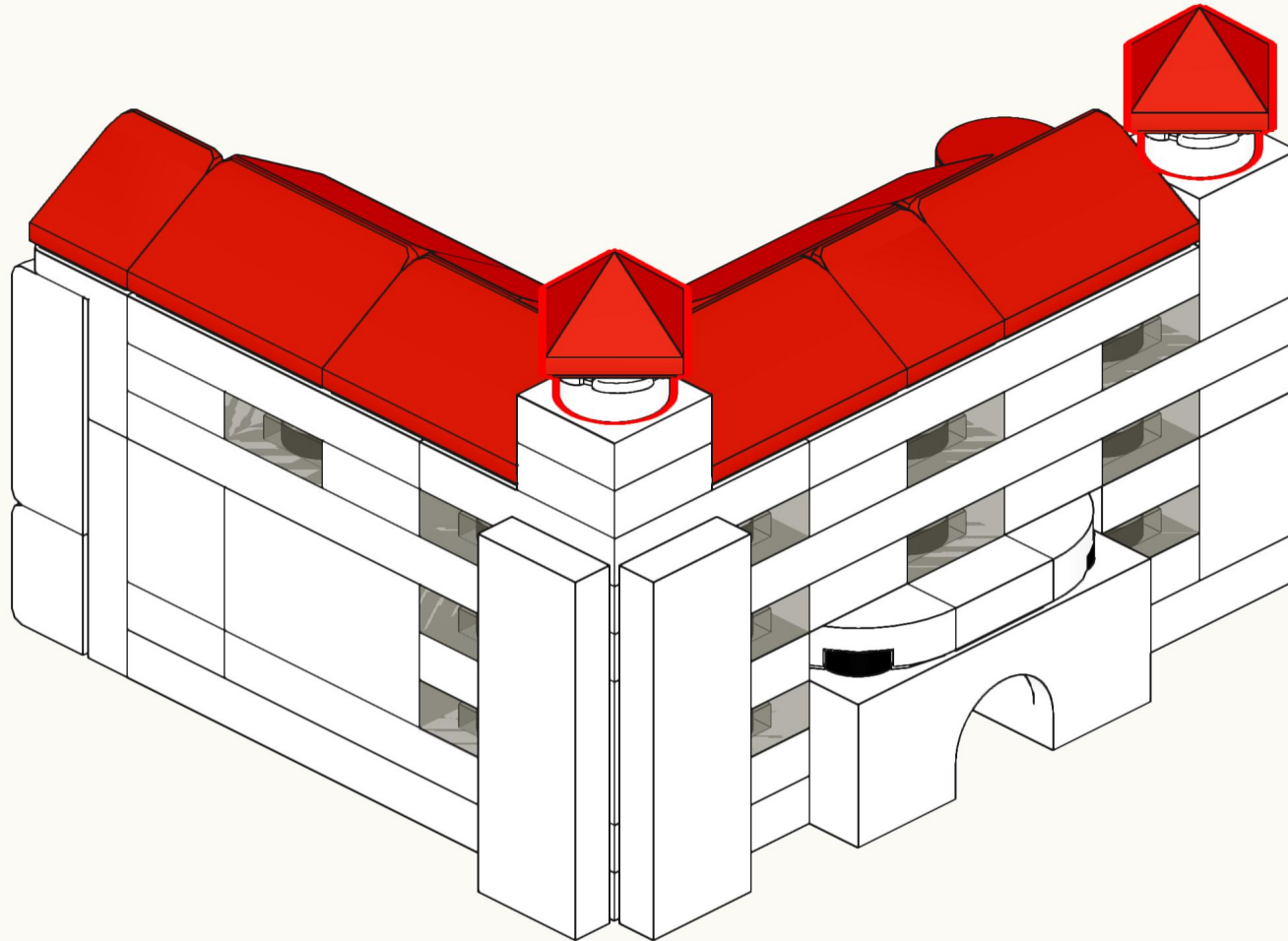

45

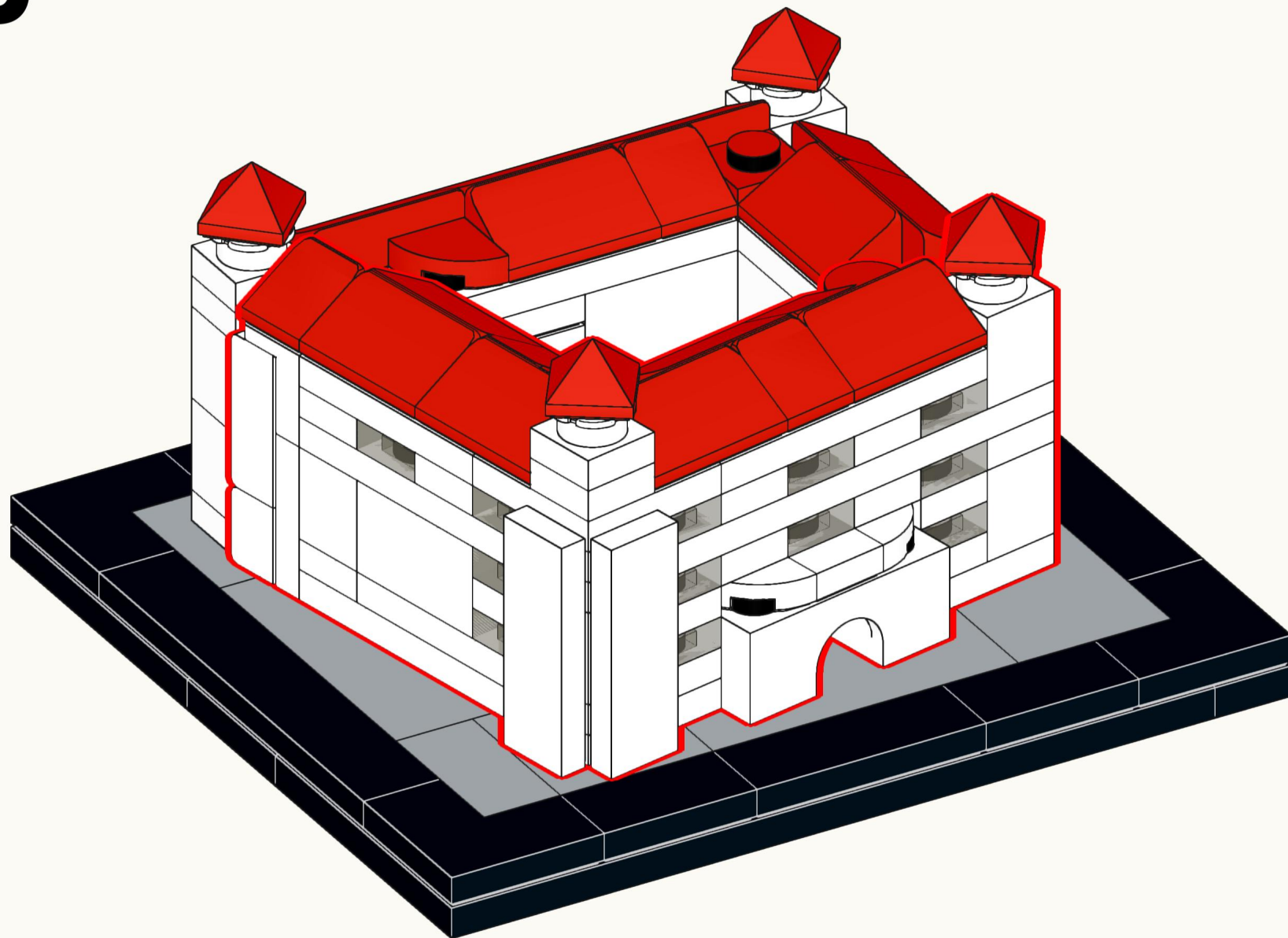

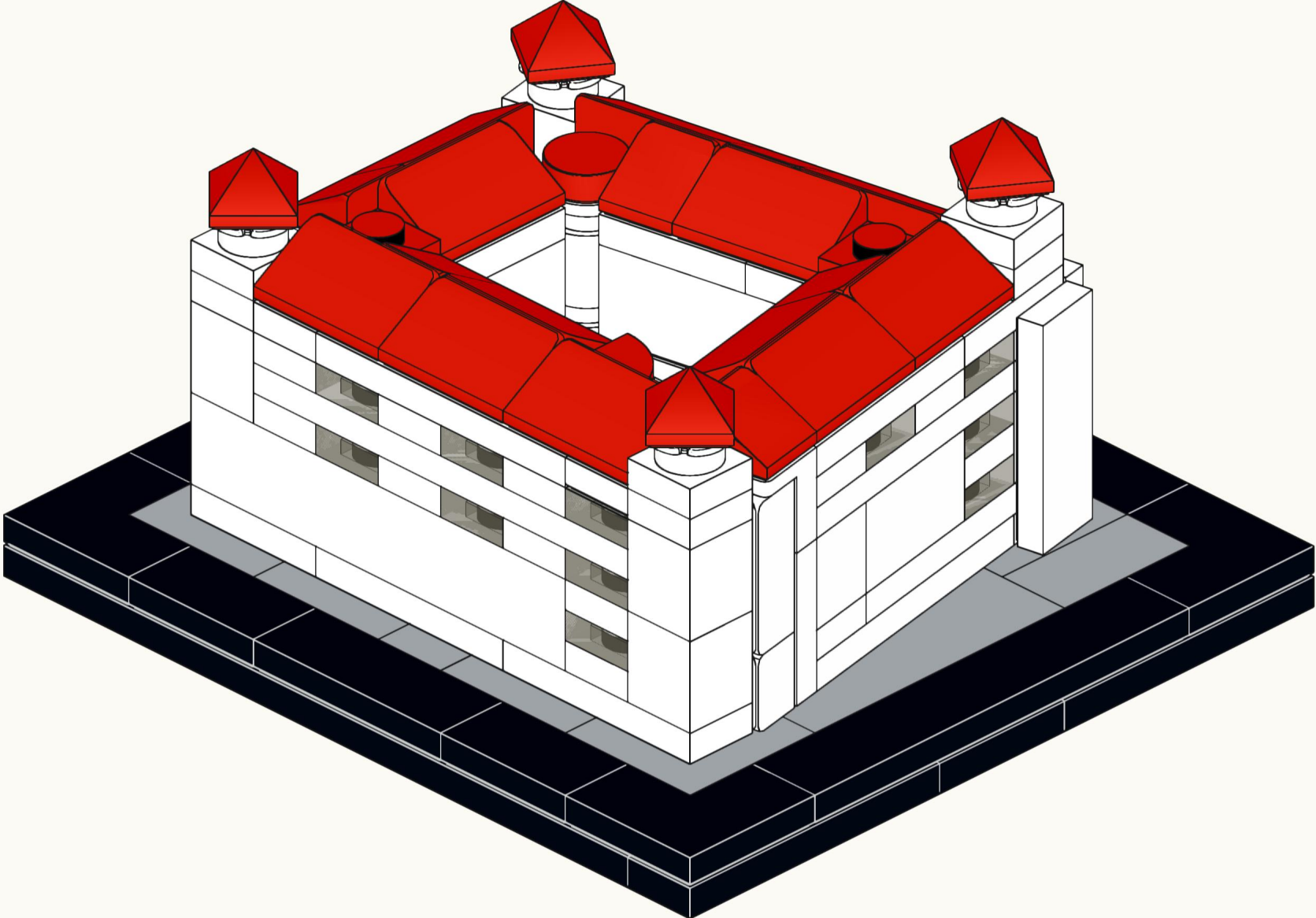



2x

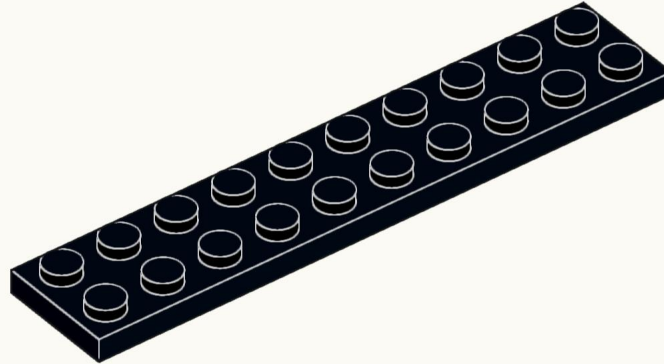

1x

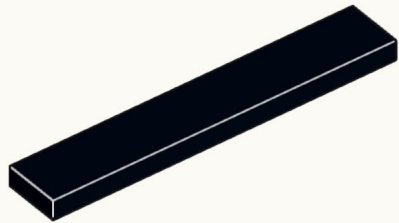

2x

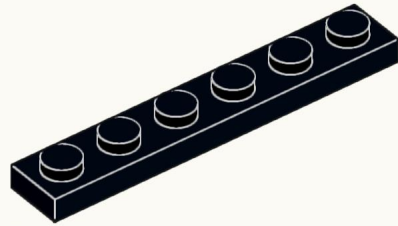

1x

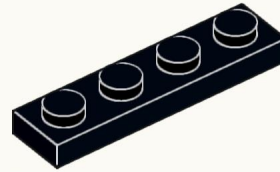

1x

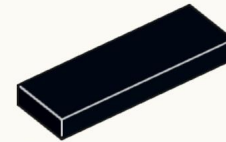

2x

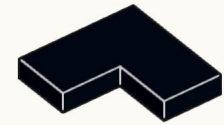

4x



4x

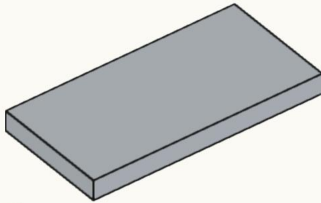

2x

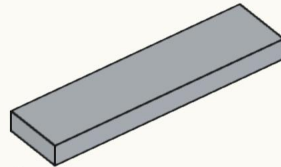

2x

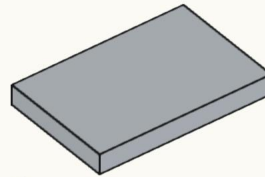

2x

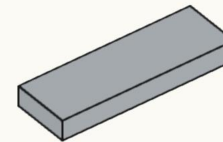

1x

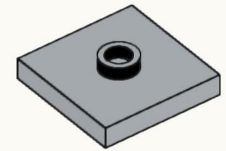

4x

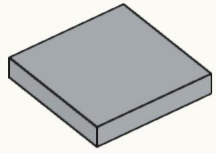

2x

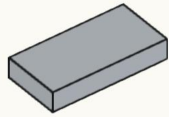

4x

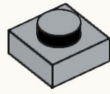

1x

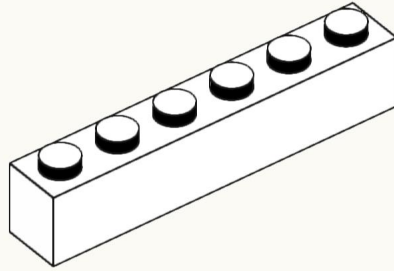

1x

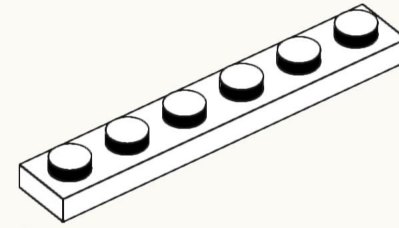

2x

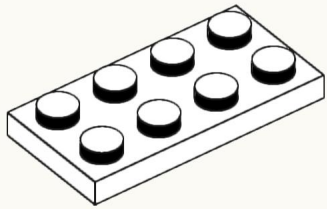

4x

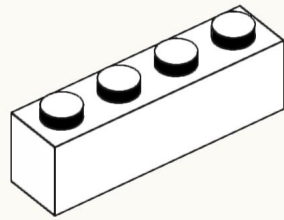

1x

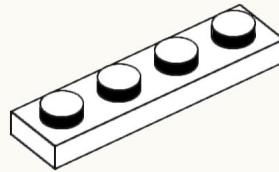

3x

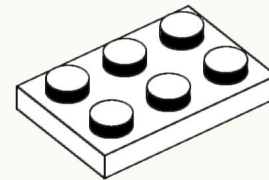

2x

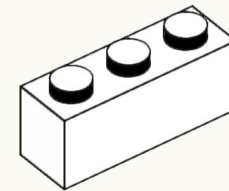

3x

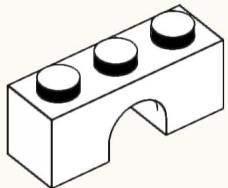

2x

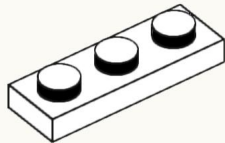

3x

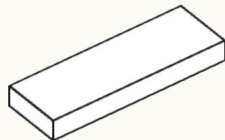

2x

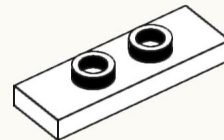

1x

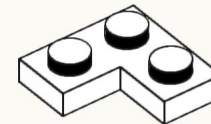

3x

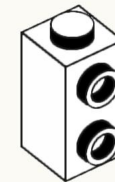

2x

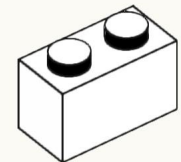

4x

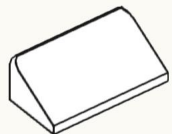

3x

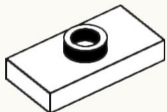

1x

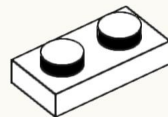

3x

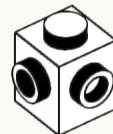

1x

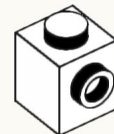

1x

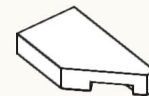

2x



2x



1x

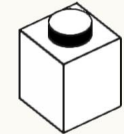

5x



2x

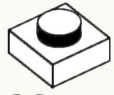

32x



3x



4x



1x

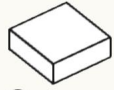

2x

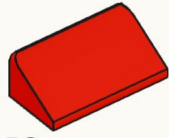

12x

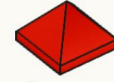

4x

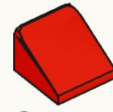

6x



2x



1x



1x



1x

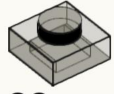

22x

