

BOBBY BRIX

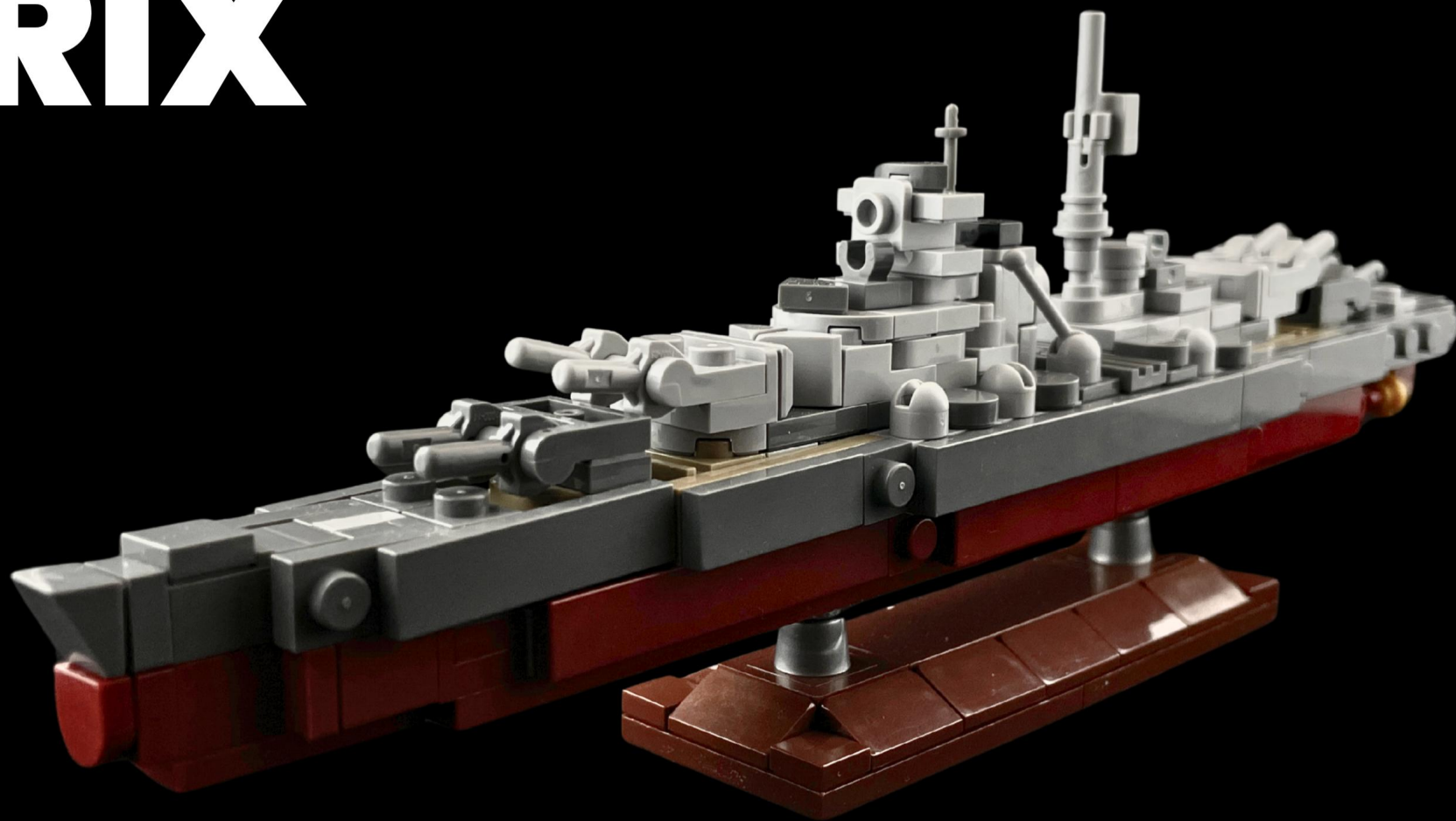

GB-009 | MOC #0354

Tirpitz was the second of the two *Bismarck-class* battleships built for Nazi Germany's Kriegsmarine and was commissioned in **1941**. Slightly heavier than her sister ship, she became the **largest battleship** ever built by a European power.

Stationed mainly in Norwegian waters, Tirpitz served as a powerful deterrent to Allied convoys bound for the Soviet Union. Her presence alone forced the Royal Navy to keep large forces on standby, even though she rarely engaged in direct combat.

Despite her limited action, Tirpitz participated in several operations along the Norwegian coast before becoming the target of repeated Allied attacks. British submarines damaged her in **1943**, and later air raids from Royal Air Force bombers finally sank her near **Tromsø** on **12 November 1944**.

The sinking of Tirpitz ended the threat of German surface ships in the Arctic.

TIRPITZ BATTLESHIP MOC + DISPLAY STAND

MODEL #0354B	UNITS	WIDTH	LENGTH	HEIGHT
1:1000 SCALE	STUDS	4.4	31.2	10.6
257 PARTS + SPARES	INCHES	1.4	9.8	3.3
DESIGNED IN 2026	CENTIMETERS	3.5	24.9	8.5

This My Own Creation (MOC) is an original design and product by BOBBY BRIX.

- Usage: For personal and non-commercial use only. Redistribution or reselling without permission is prohibited.
- Attribution: You may reuse, remix, or adapt this product with proper credit to the creator and original design.
- Ownership: All designs, images, and materials are owned by BOBBY BRIX & The Bobby Brix Channel unless stated otherwise.

For inquiries about public display, commercial use, or resale, please contact BOBBY BRIX.

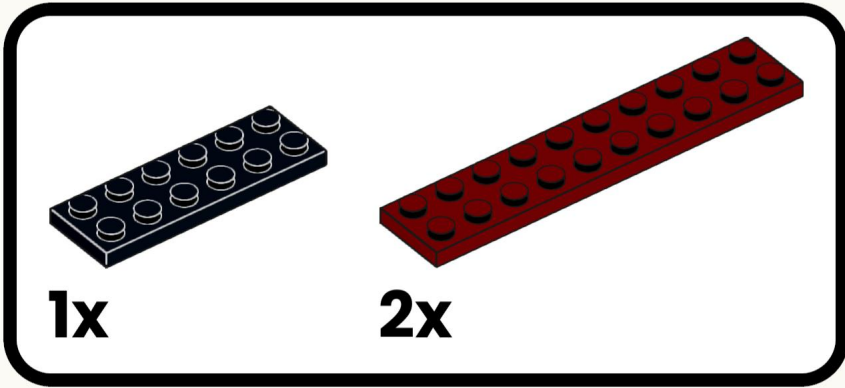
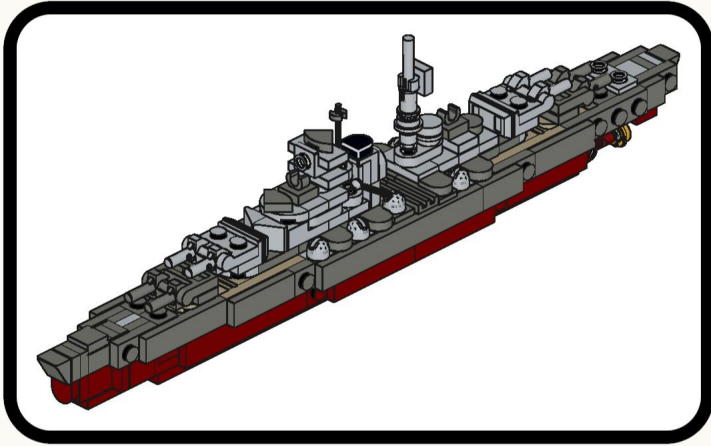

1

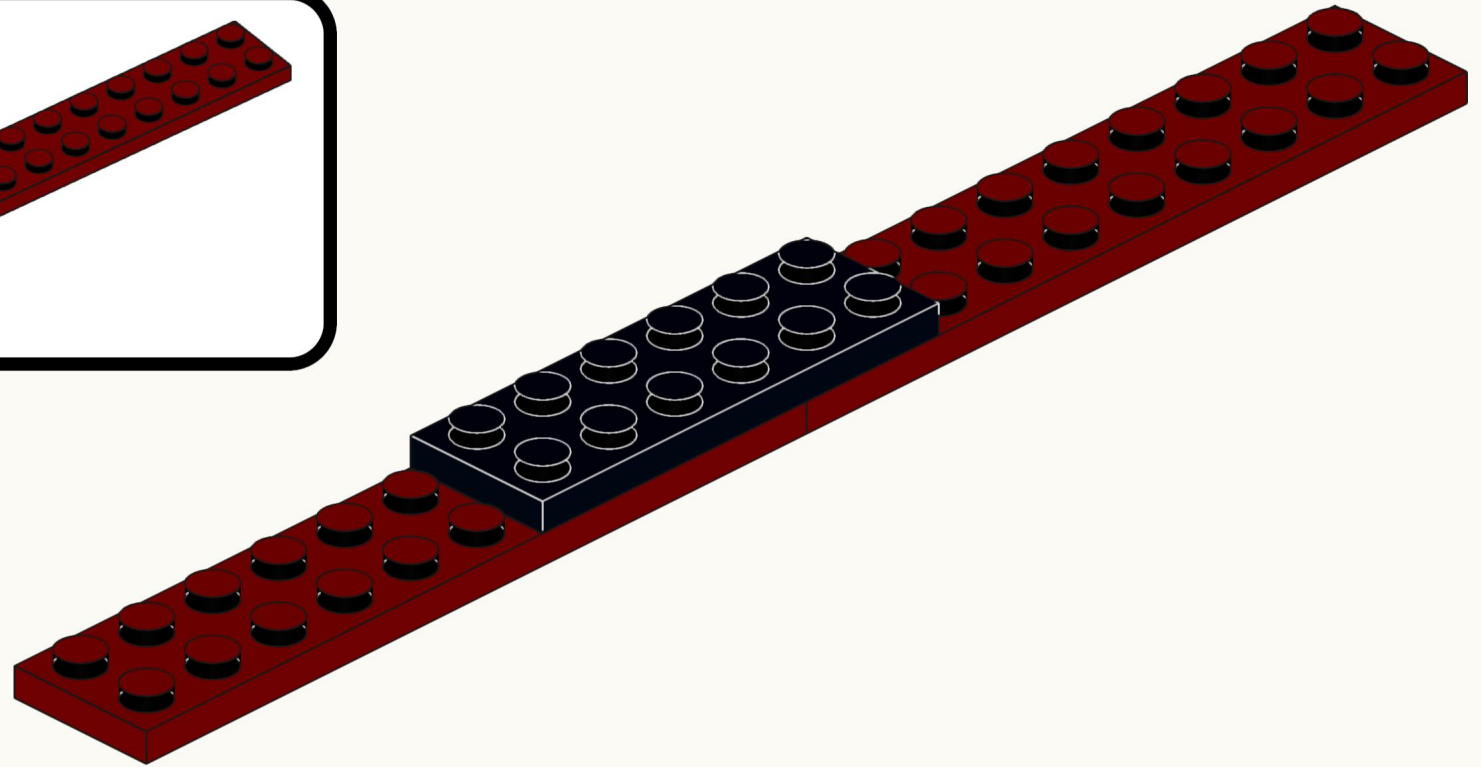

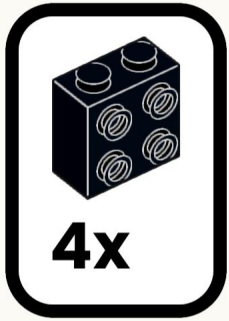

2

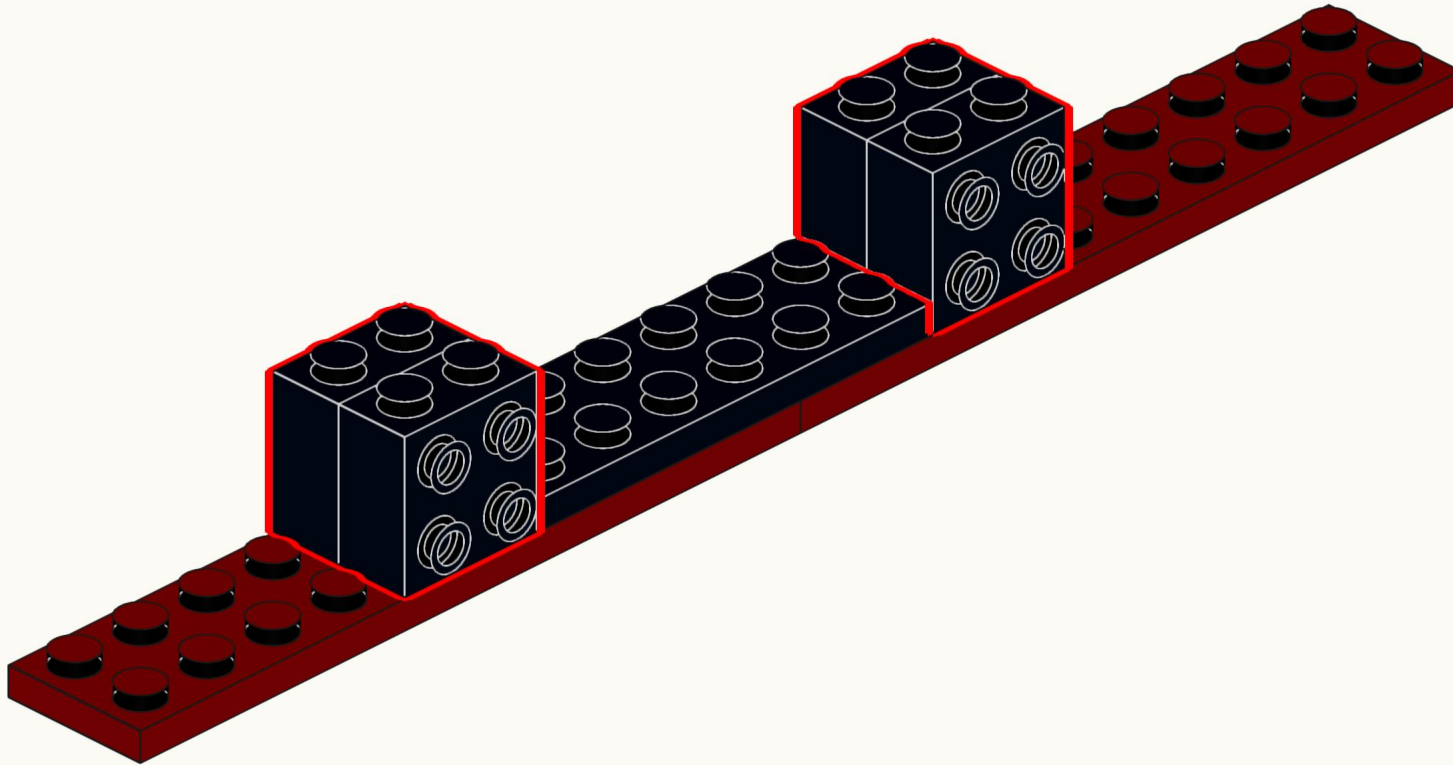

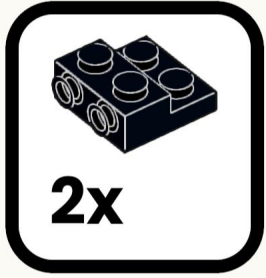

3

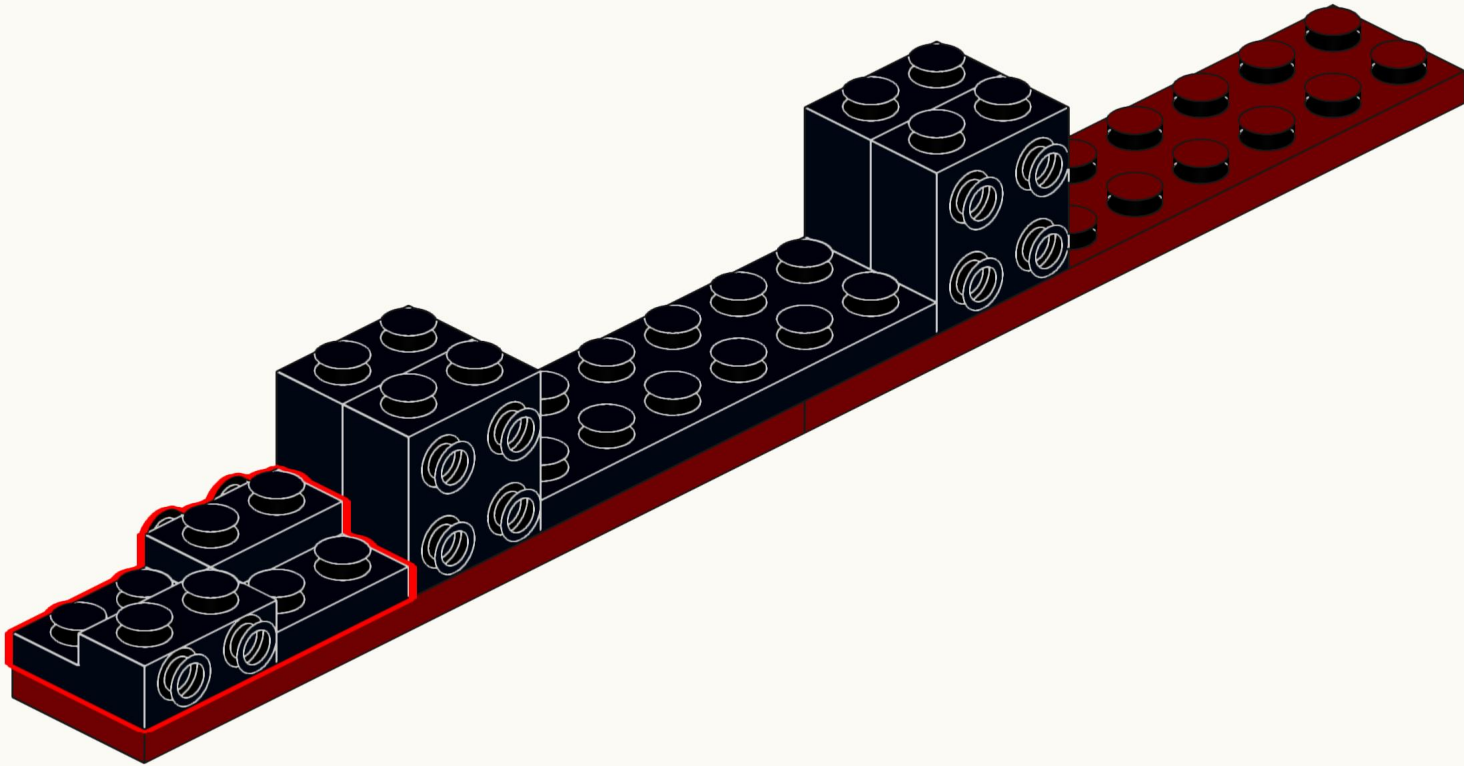

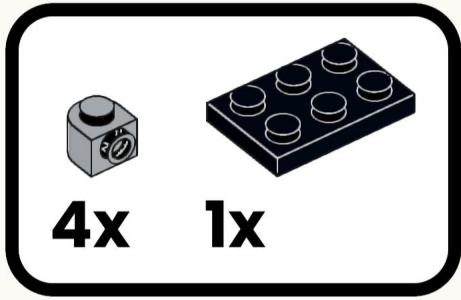

4

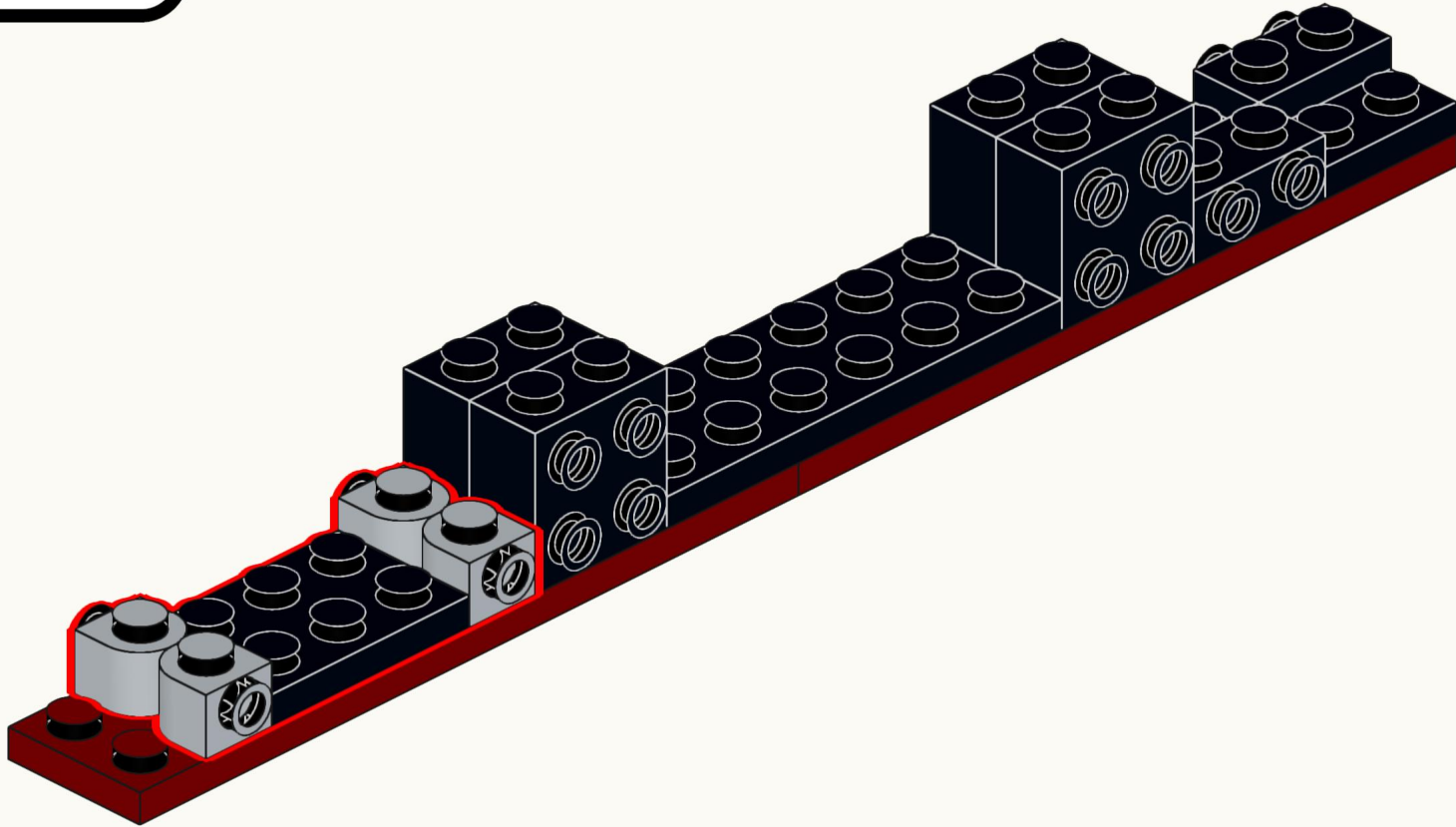

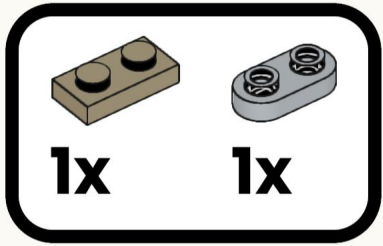

6

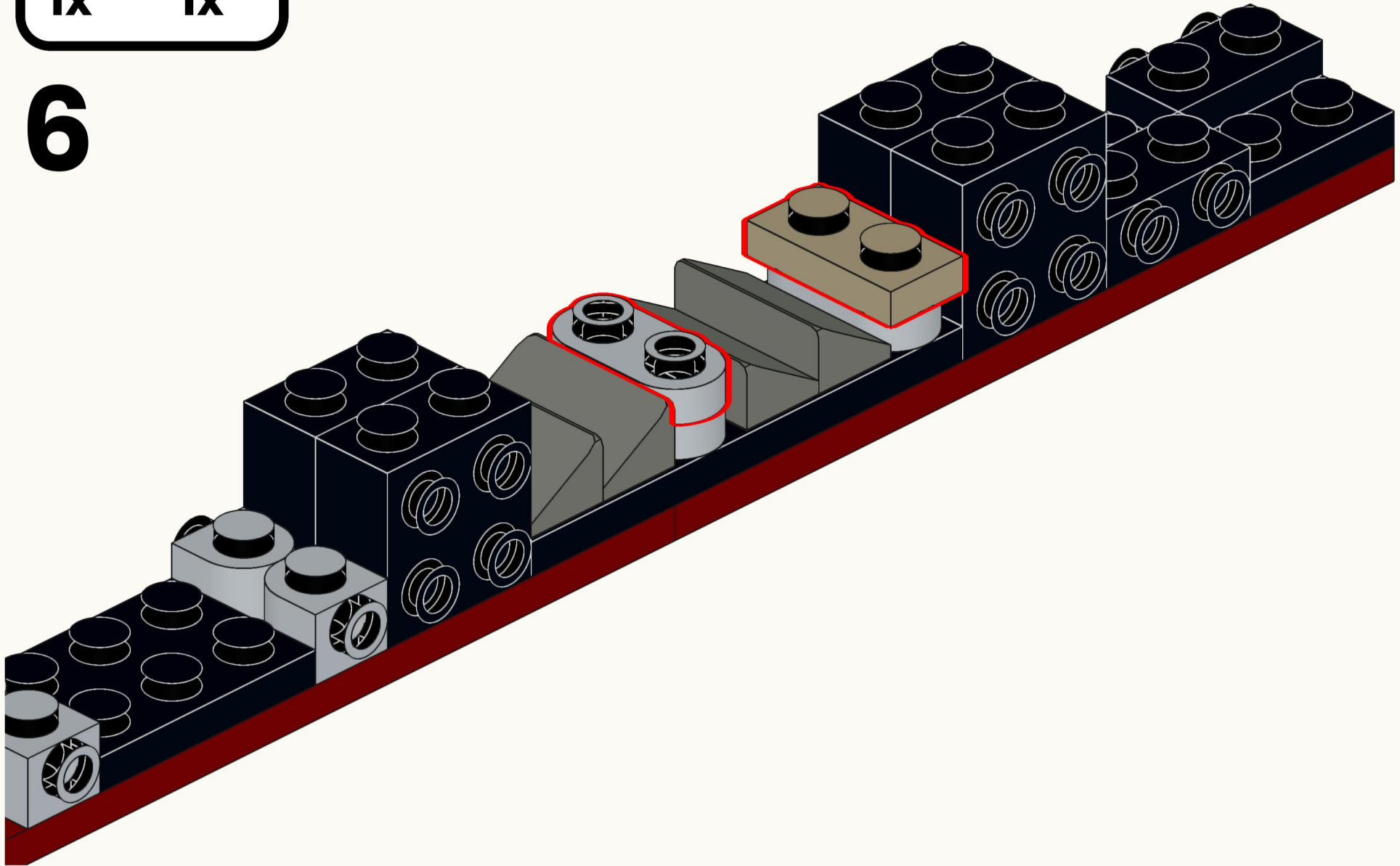

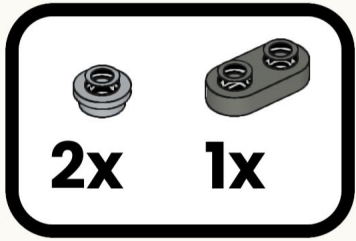

7

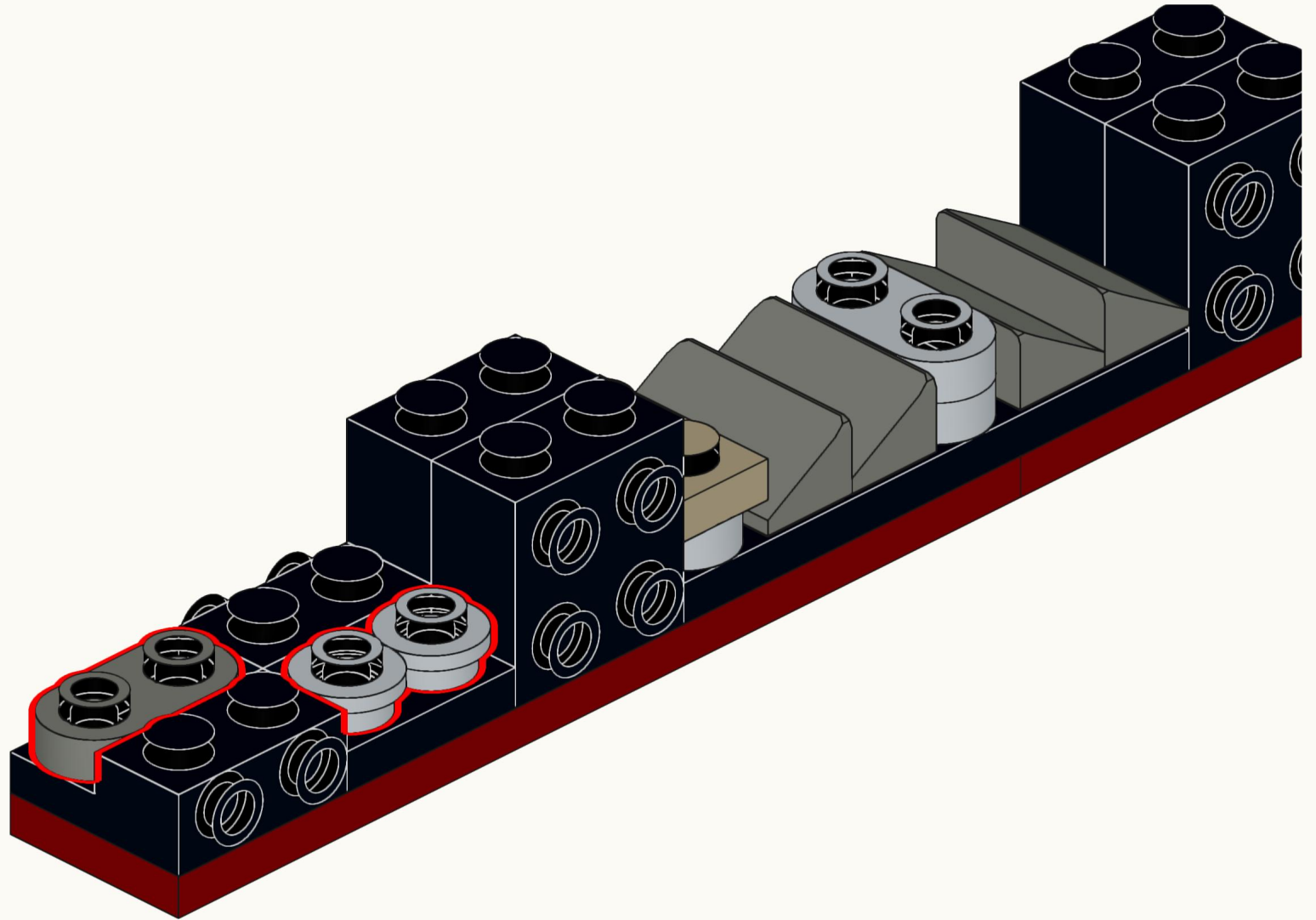

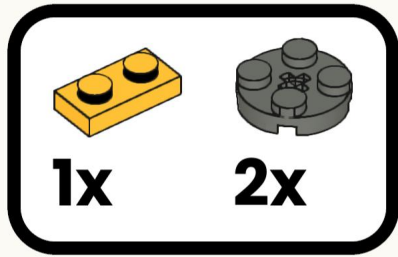

9

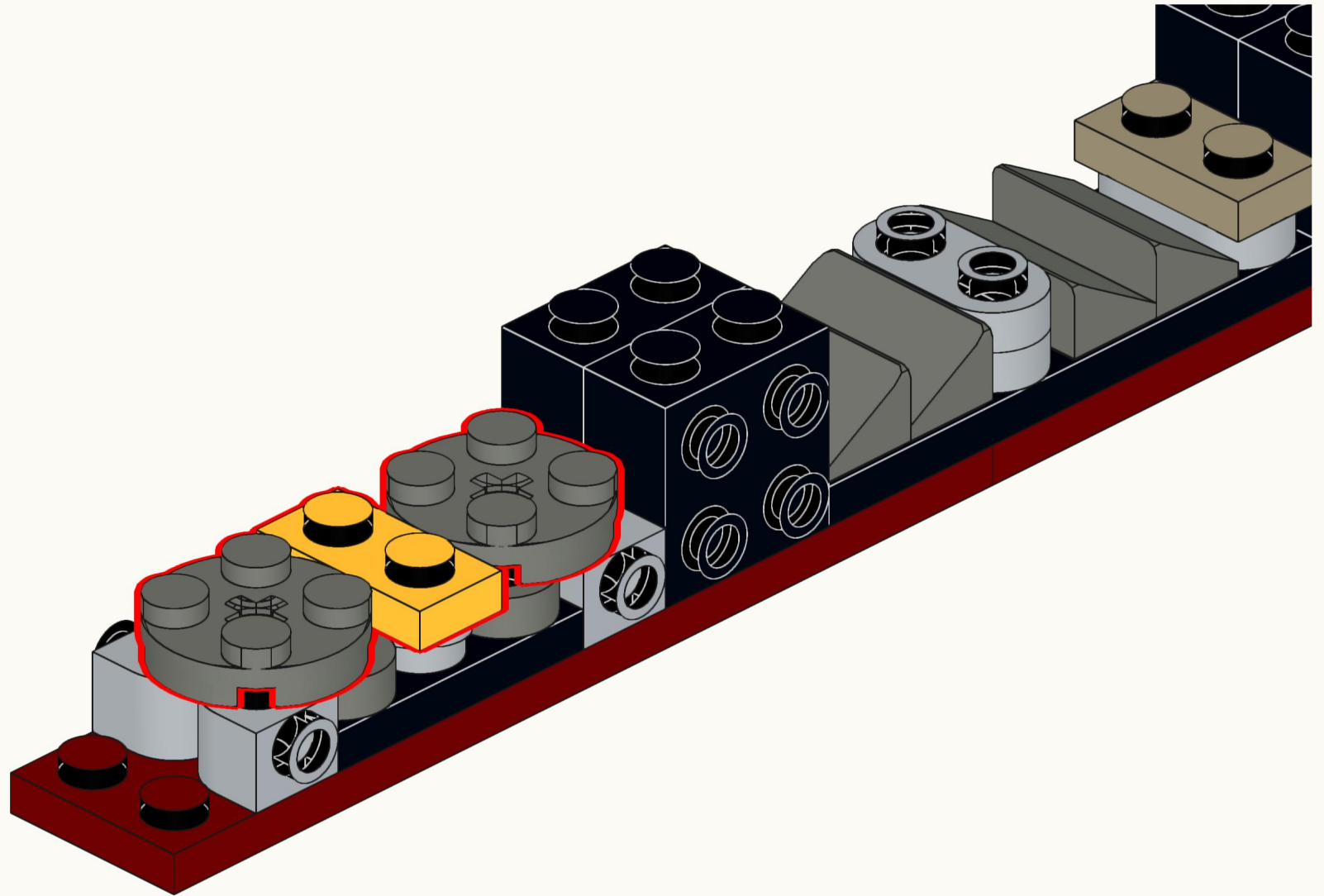

The main gun turrets were protected by 360 mm of armour on their forward faces, much thicker than the main belt armour on many contemporary warships.

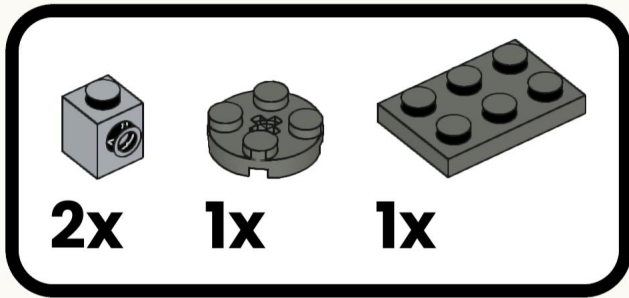

10

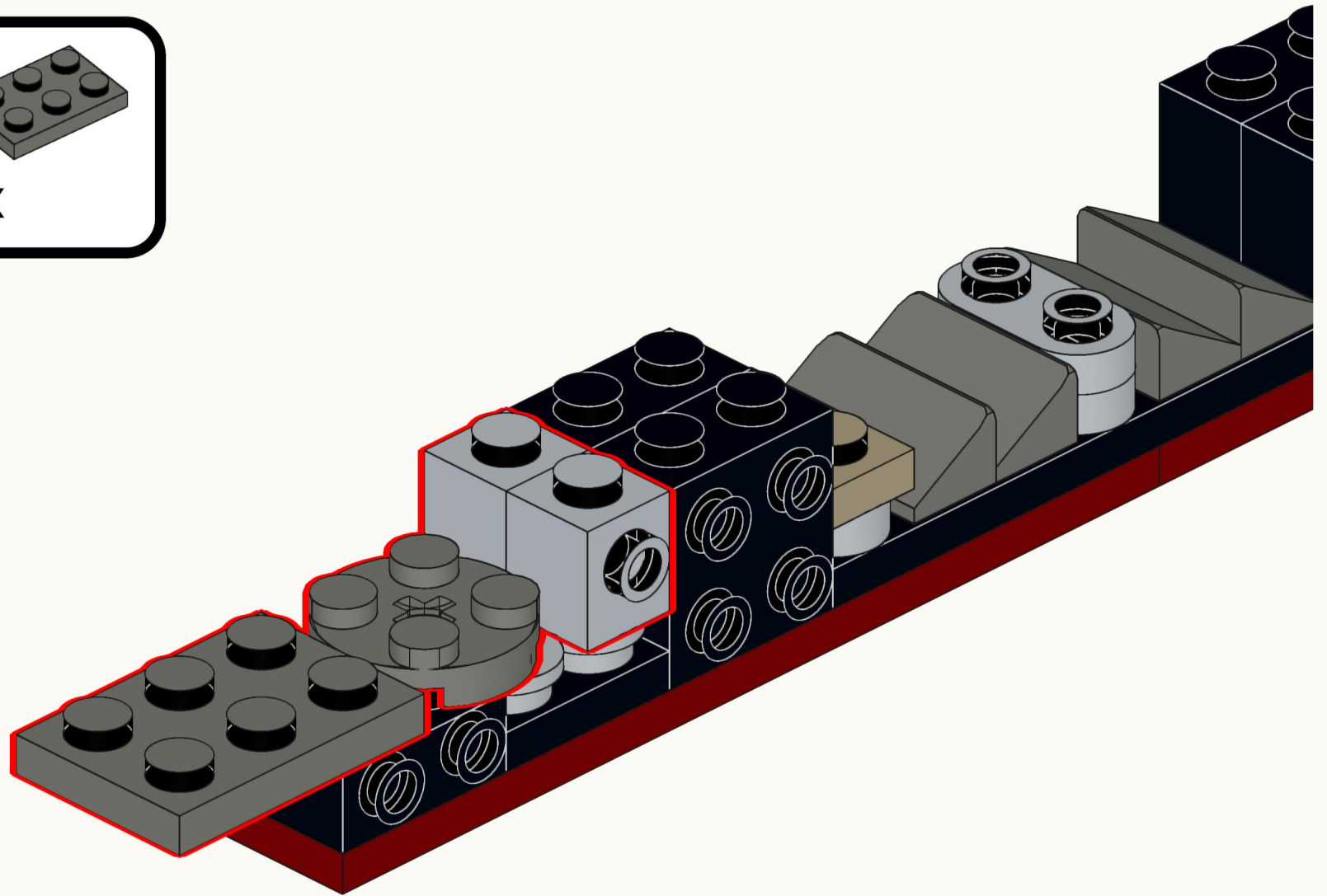

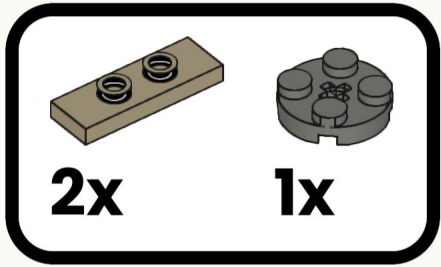

11

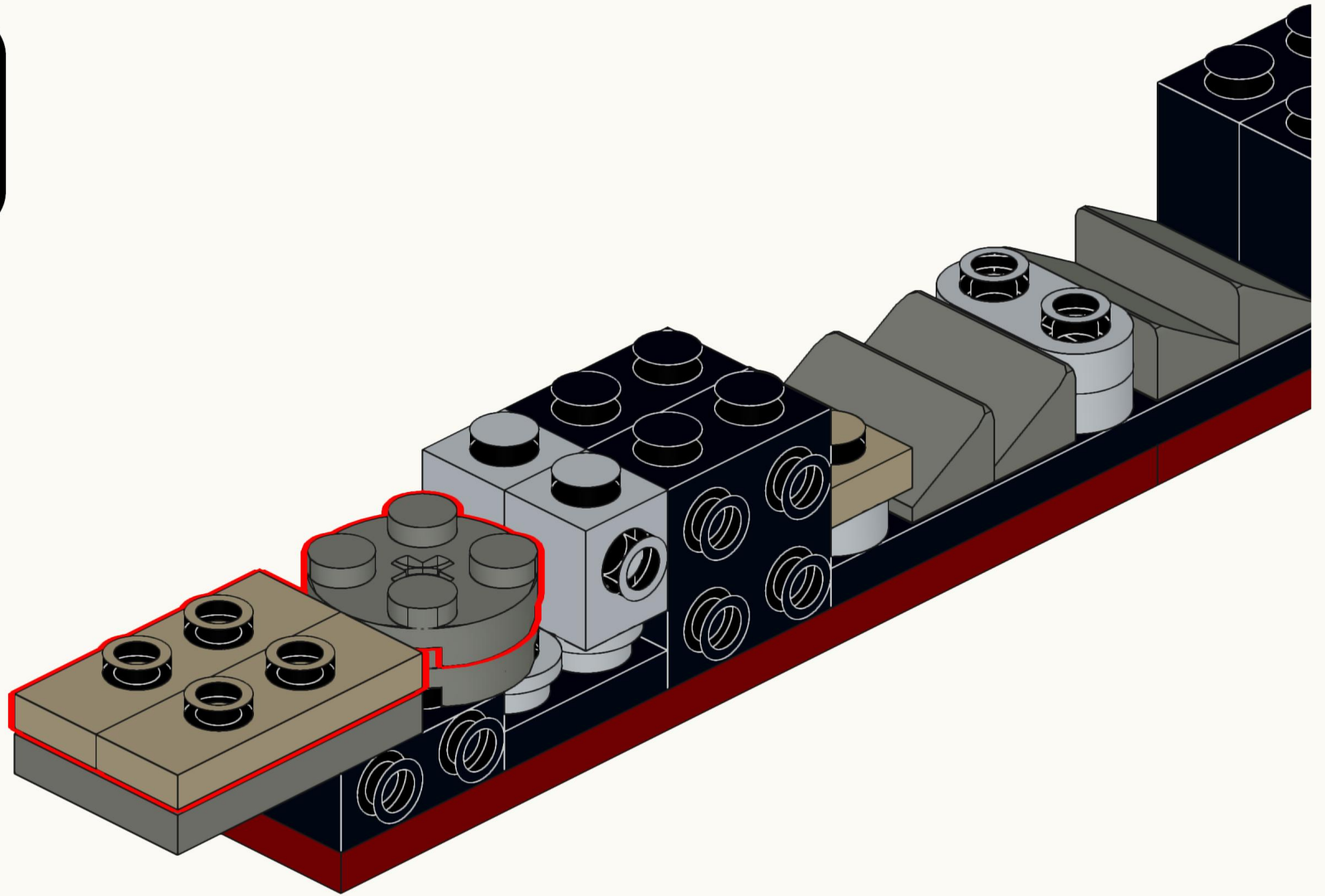

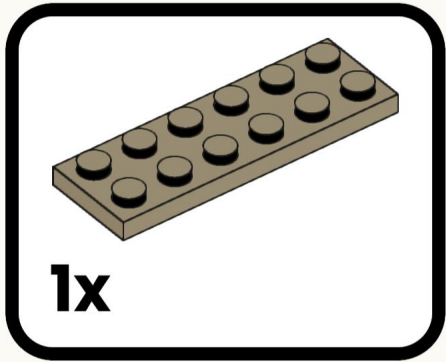

1x

12

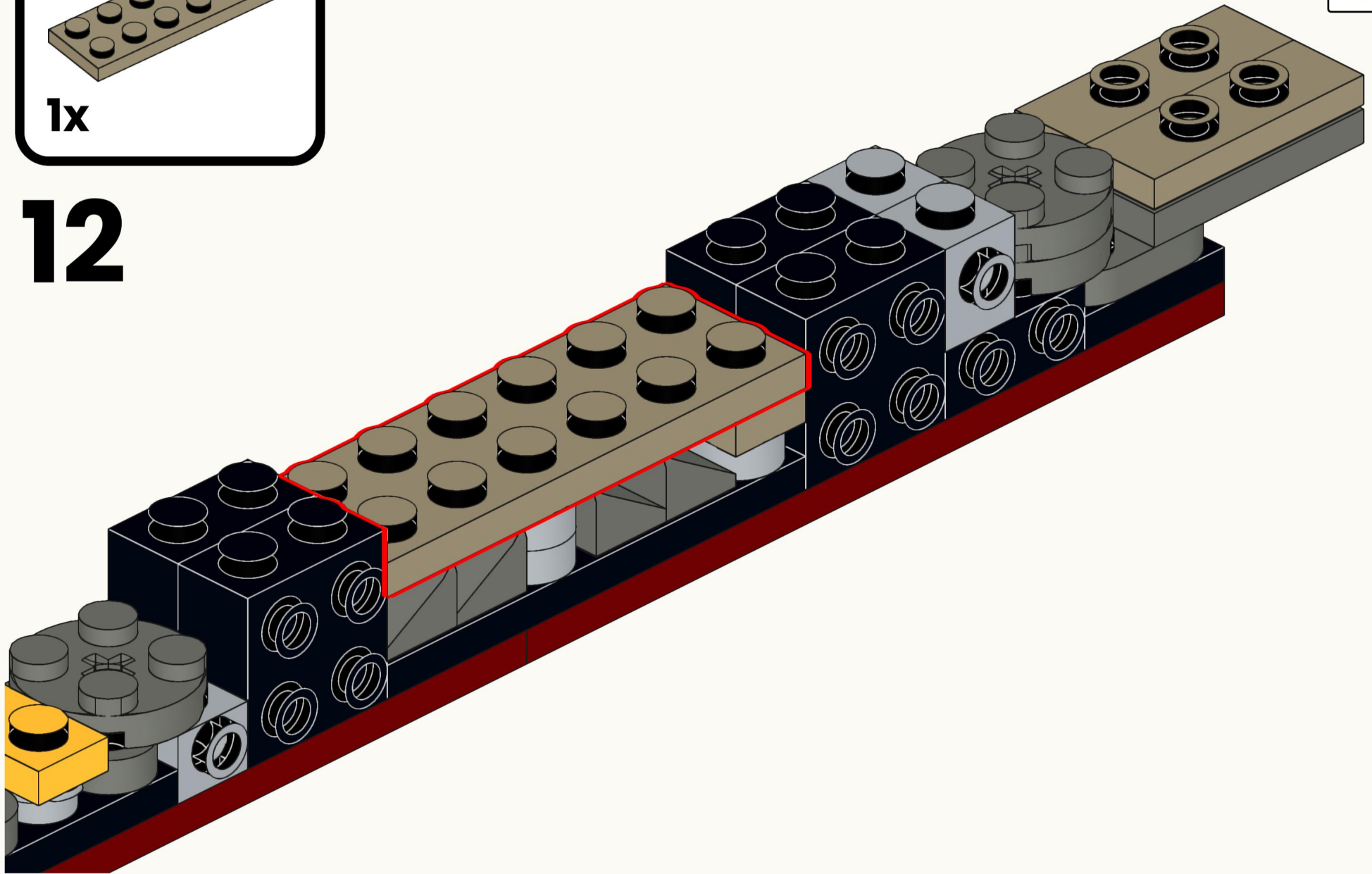

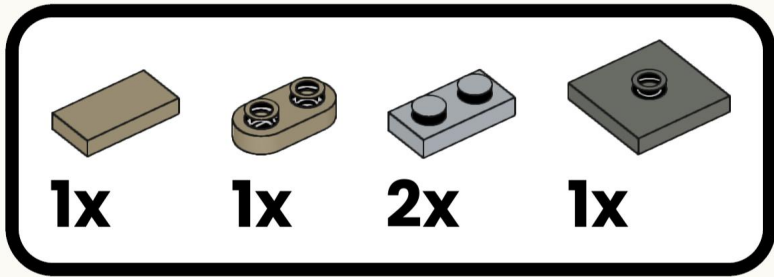

1x 1x 2x 1x

This block contains a parts list for step 13. It features four items: a tan 1x2 Technic brick, a tan 1x2 Technic axle with two holes, two grey 1x2 Technic axles with two holes each, and a grey 1x2 Technic plate with one hole. The quantities are listed below each item as 1x, 1x, 2x, and 1x respectively.

13

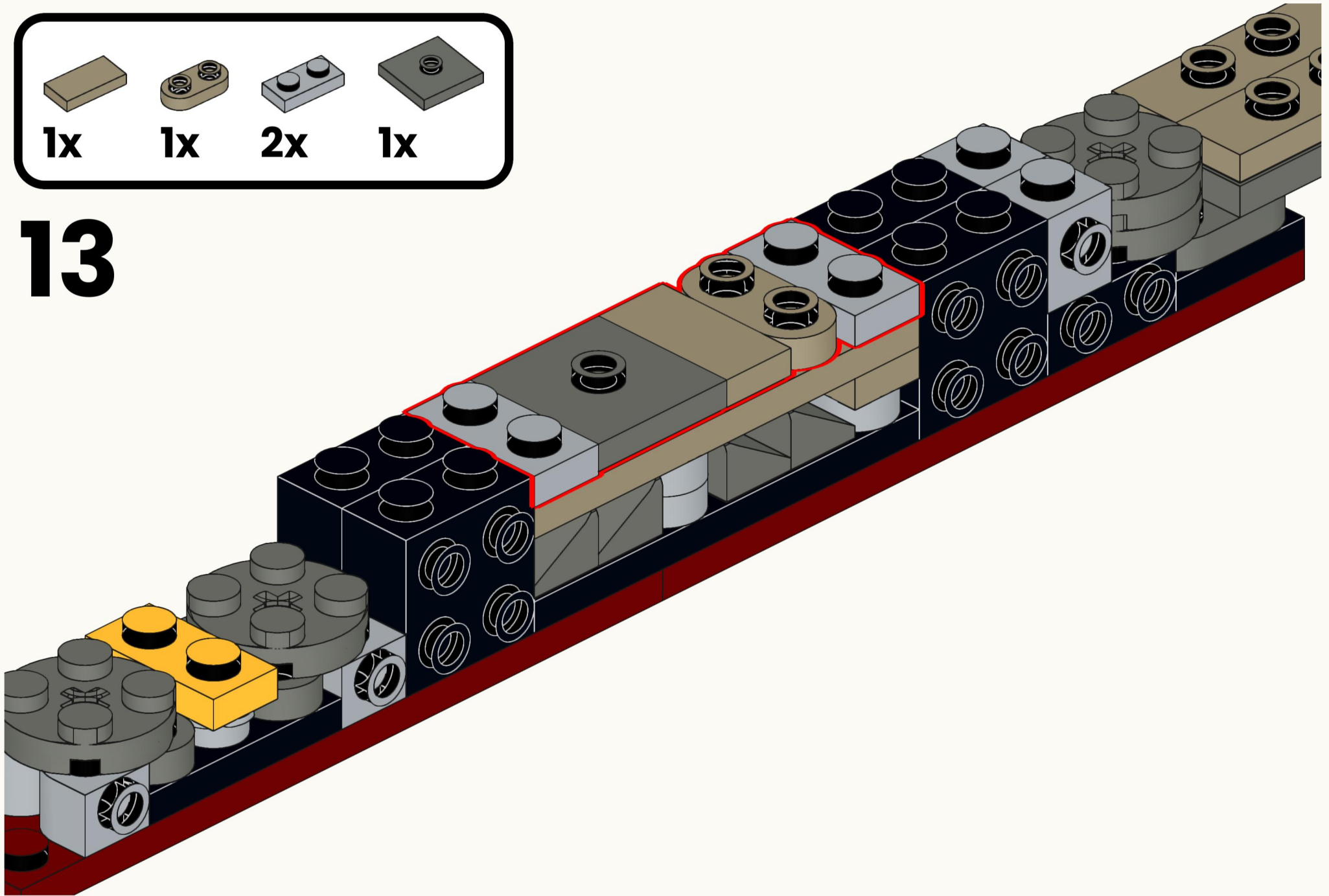

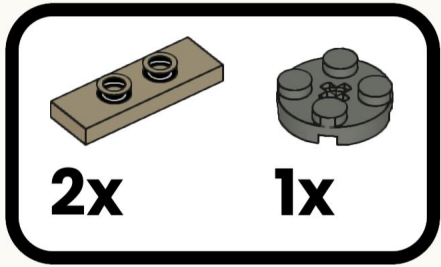

14

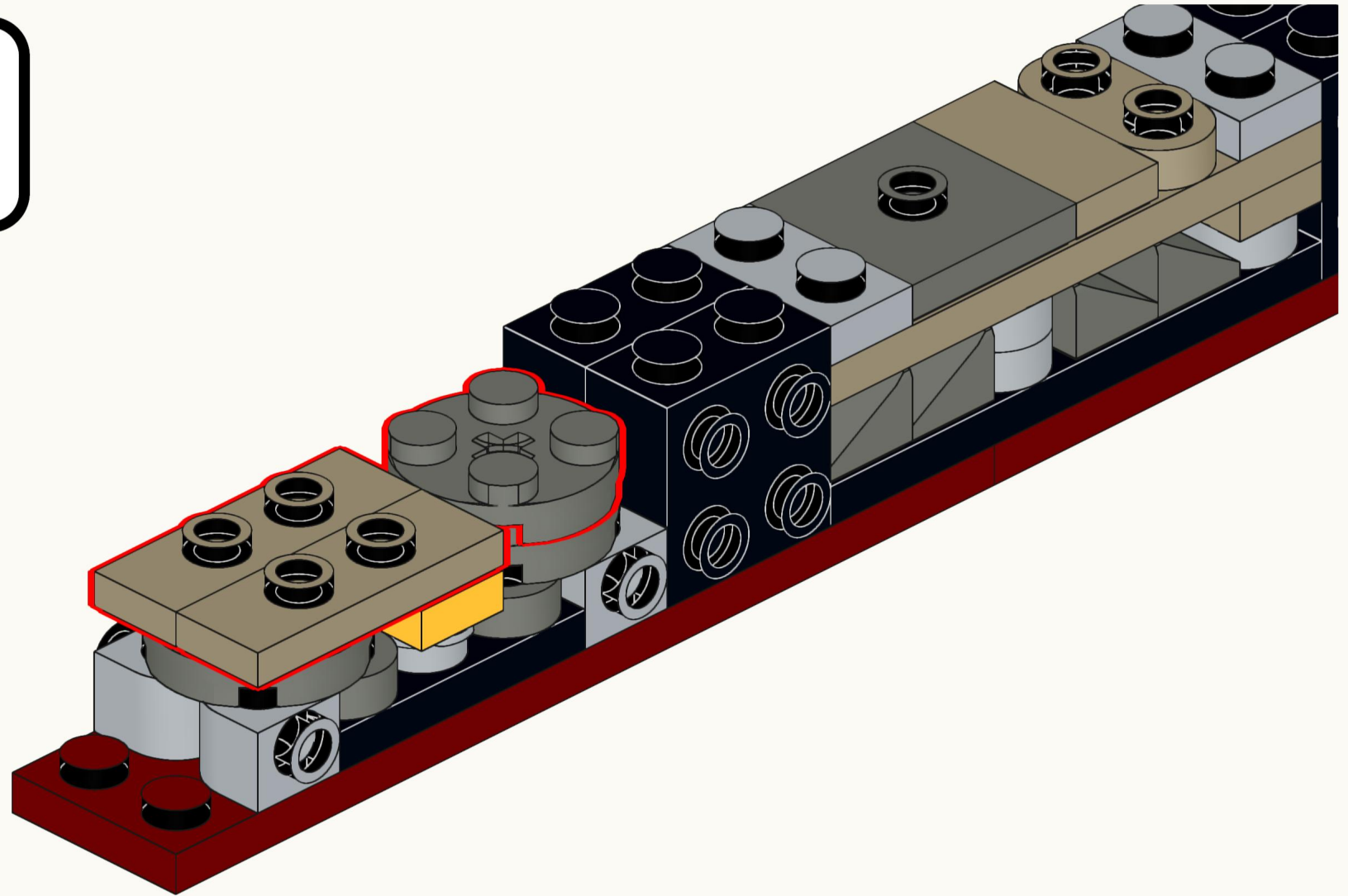

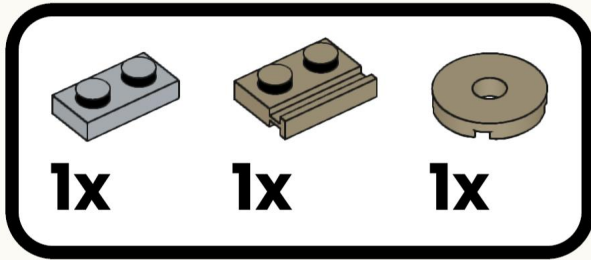

15

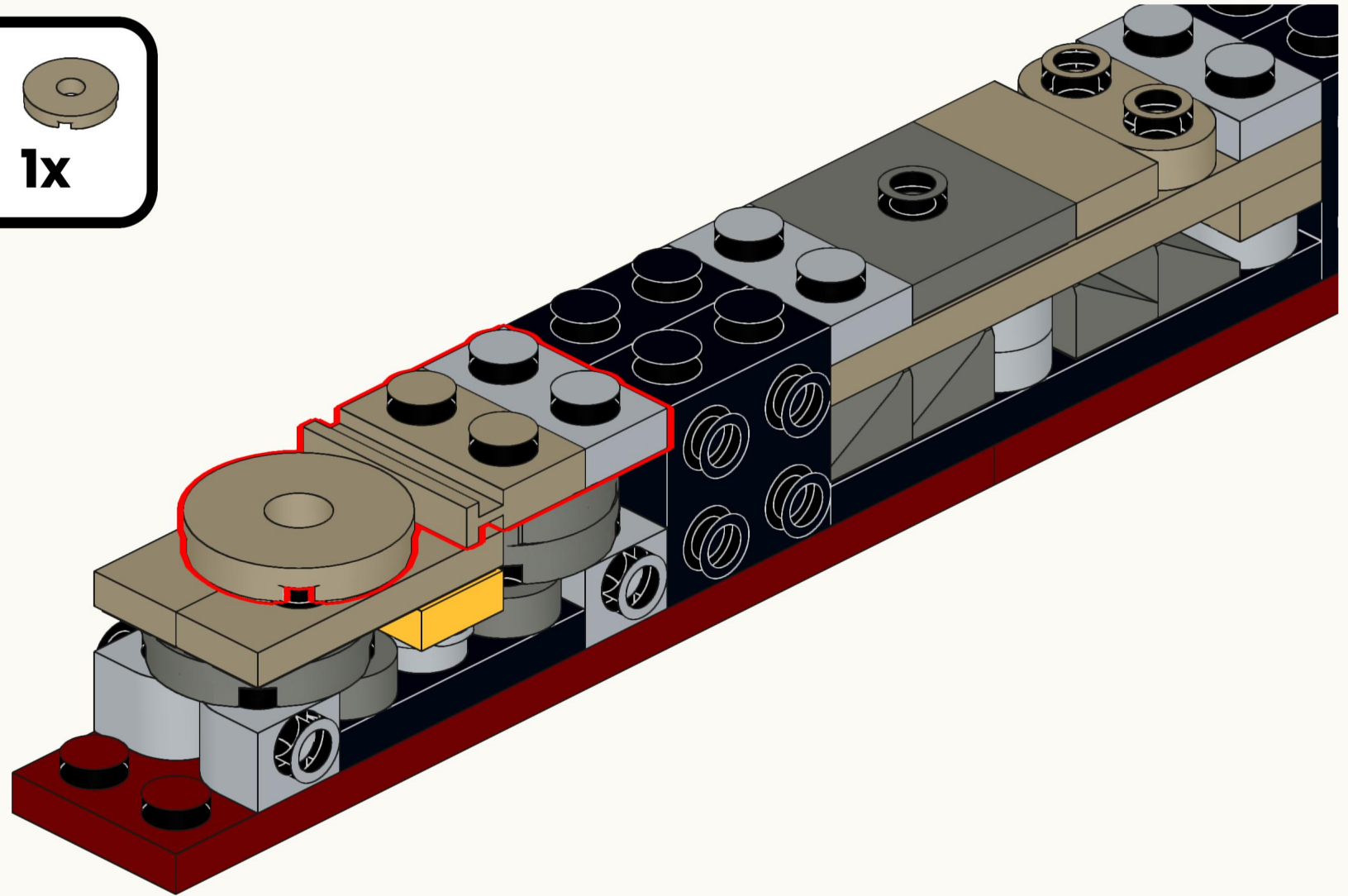

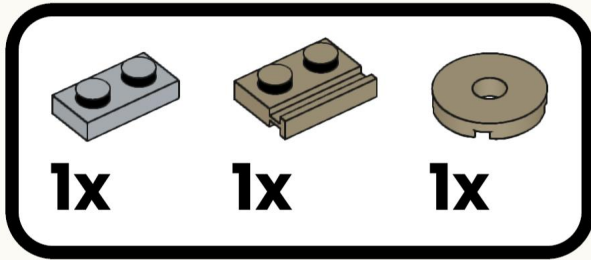

16

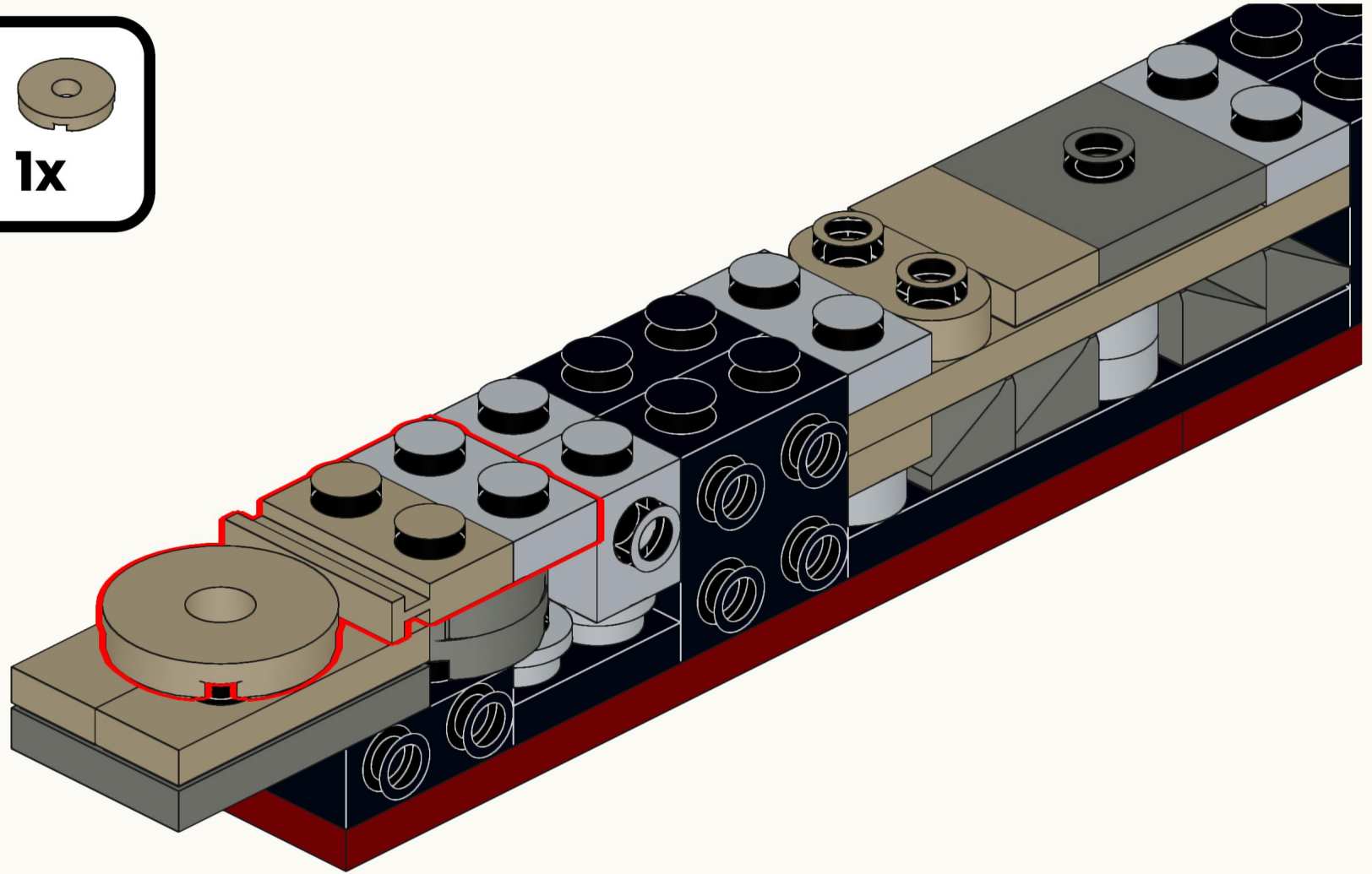

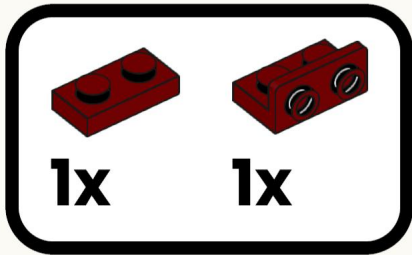
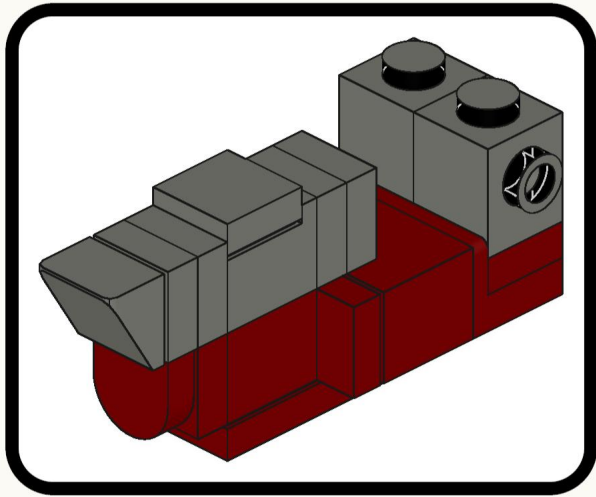

17

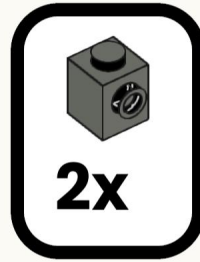
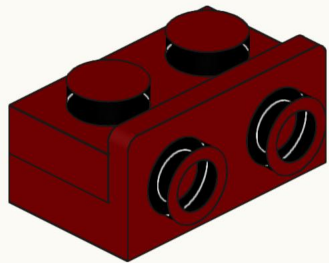

18

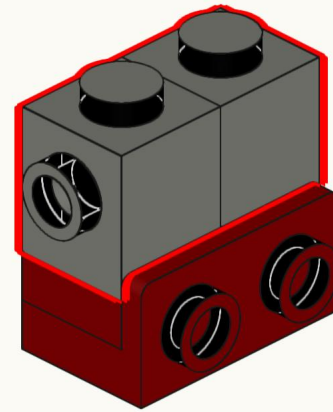

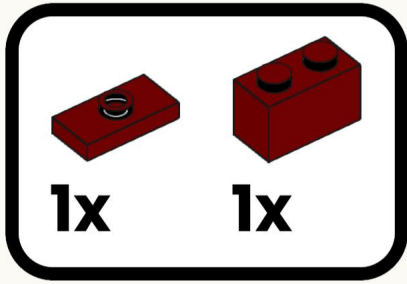

19

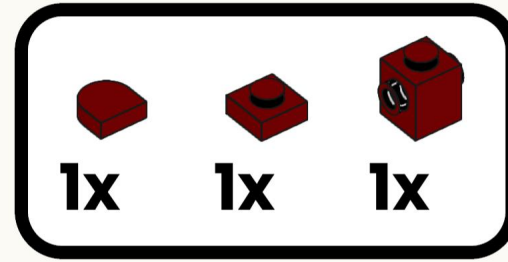
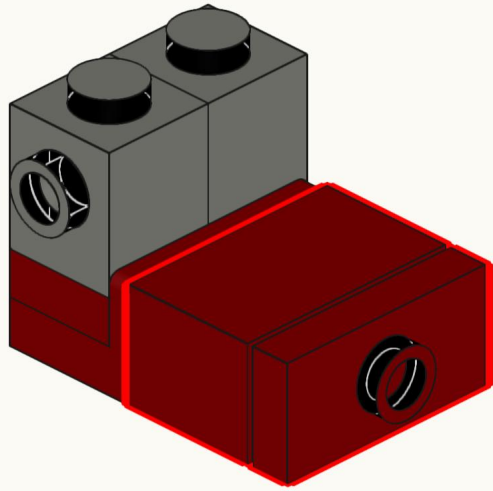

20

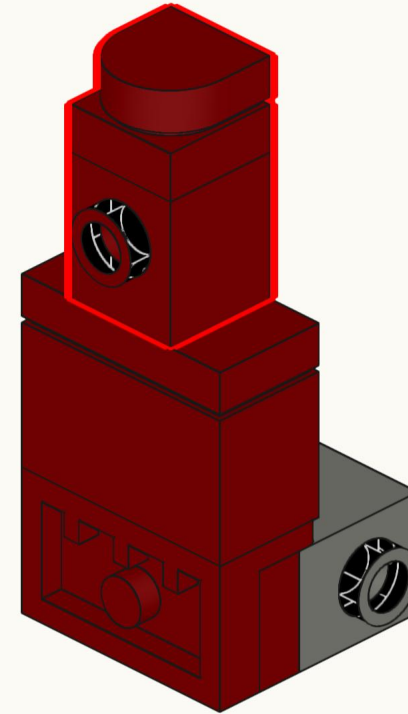

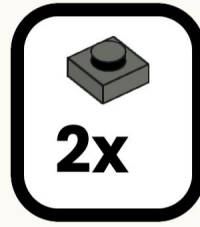
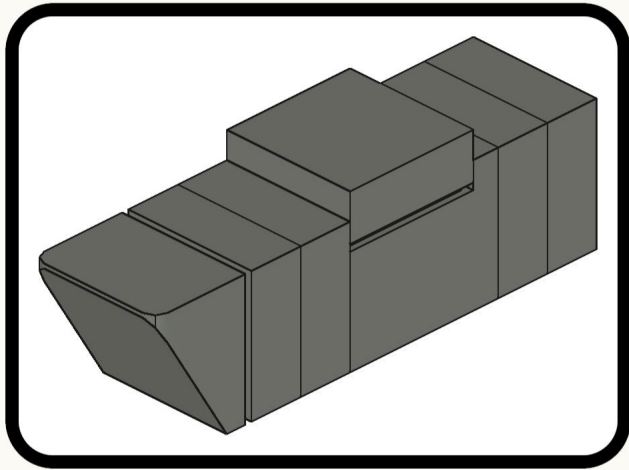

22

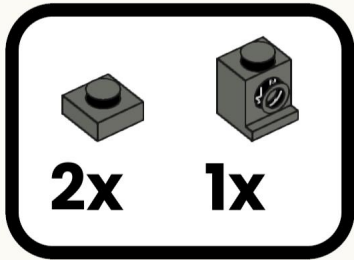

21

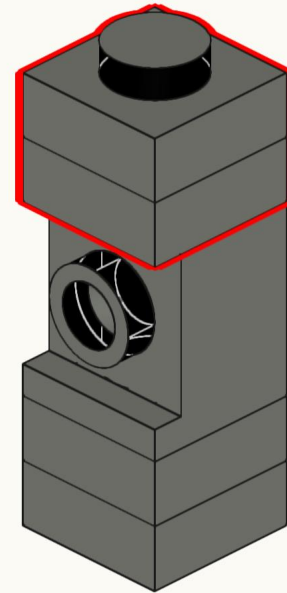
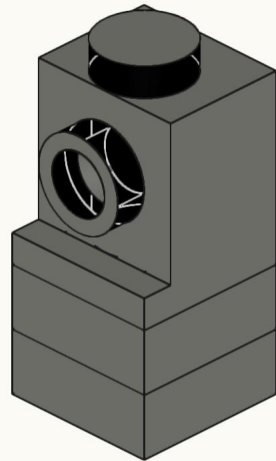

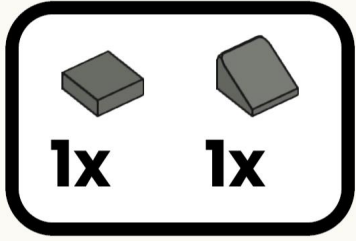

23

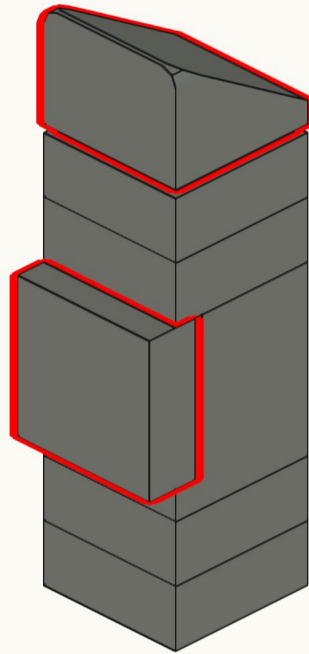

24

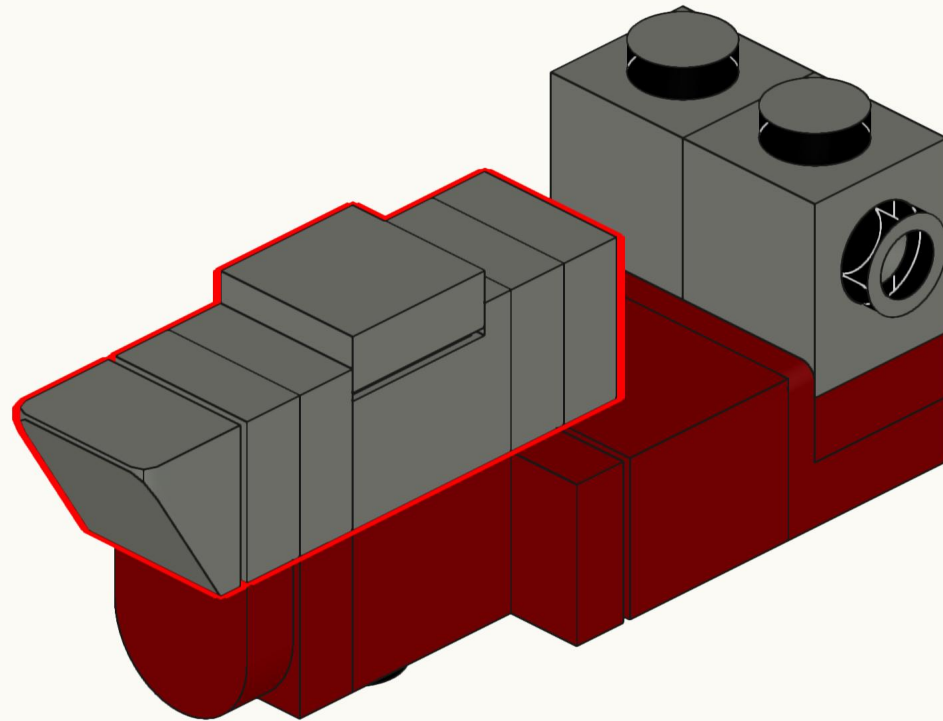

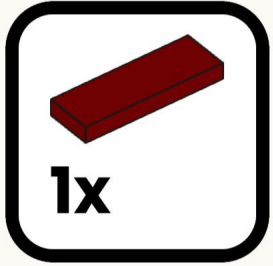

25

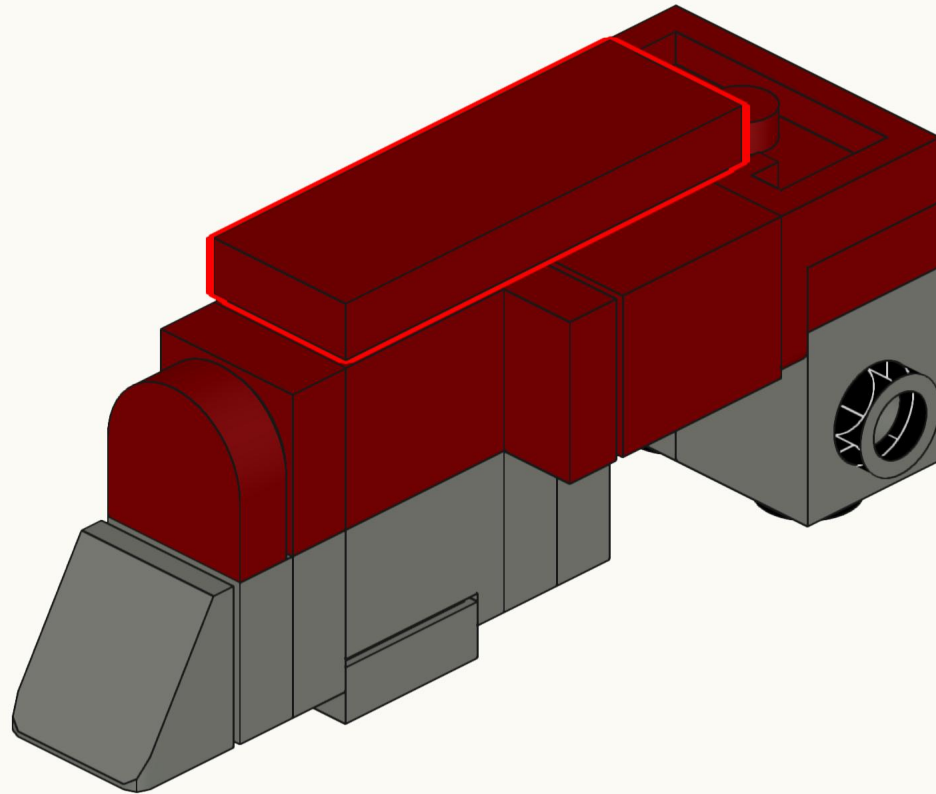

26

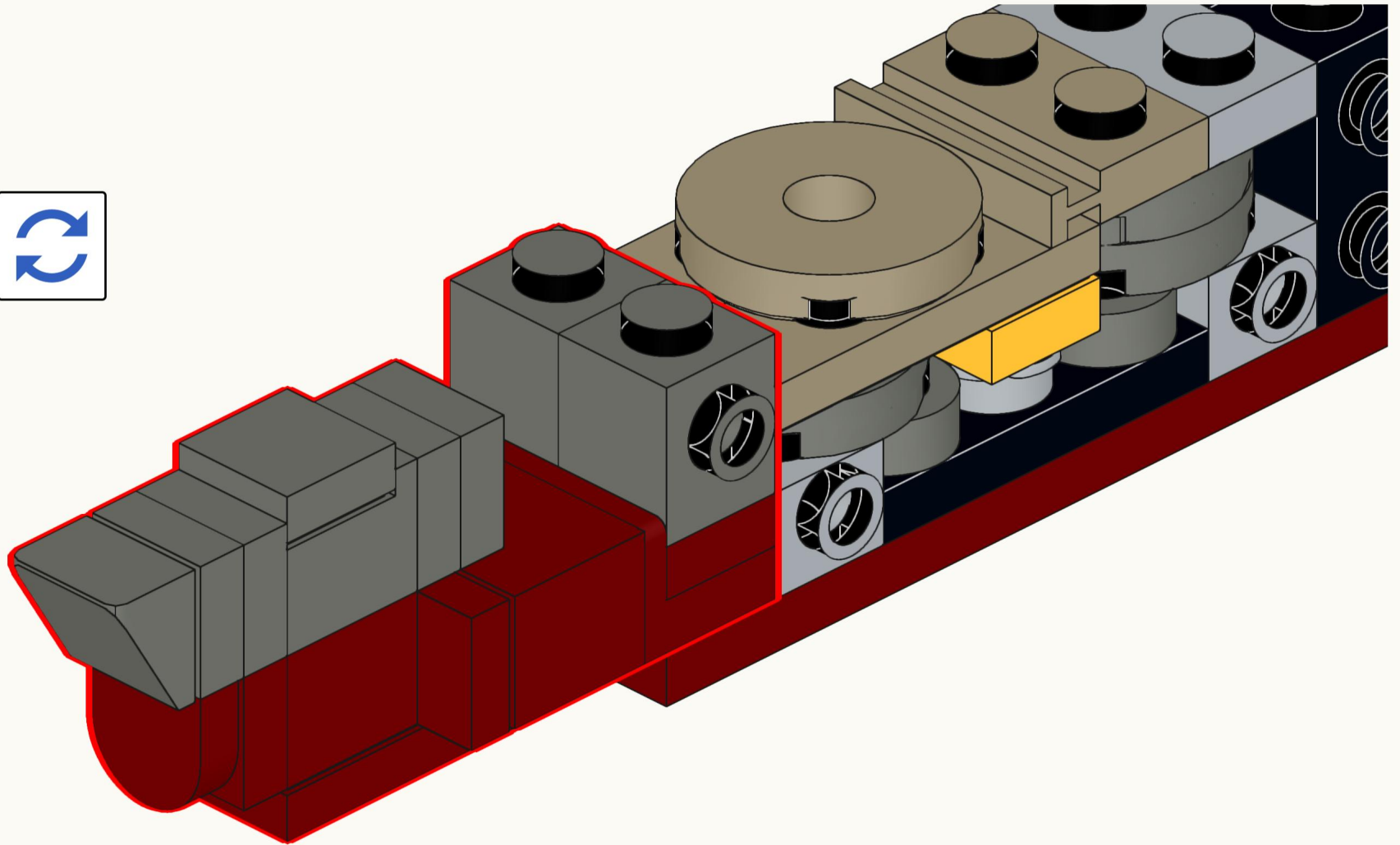

Like Bismarck, her hull used 22 watertight compartments and a double bottom running for 83% of its length. But Tirpitz was built from the start with an "Atlantic bow," the streamlined clipper-shaped prow that Bismarck only received after launch during fitting out.

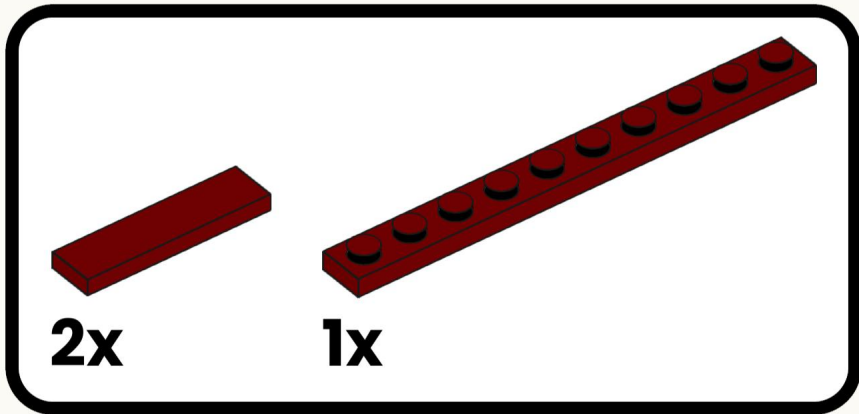
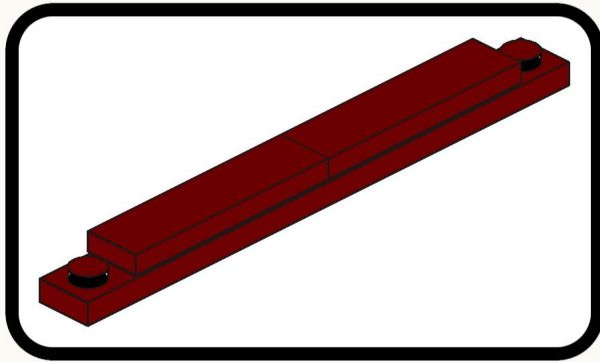

27

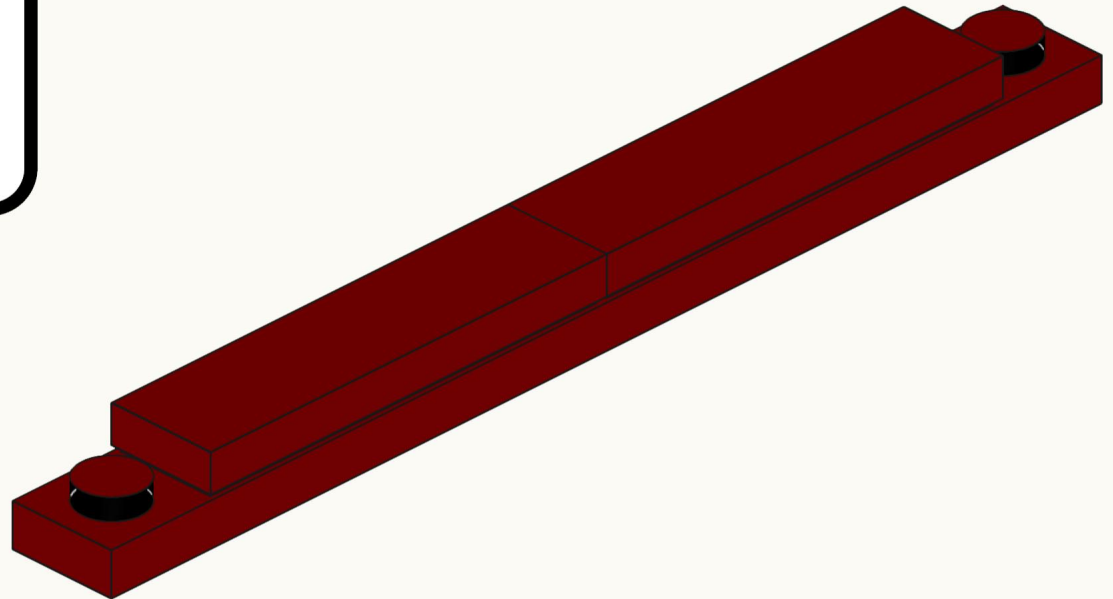

28

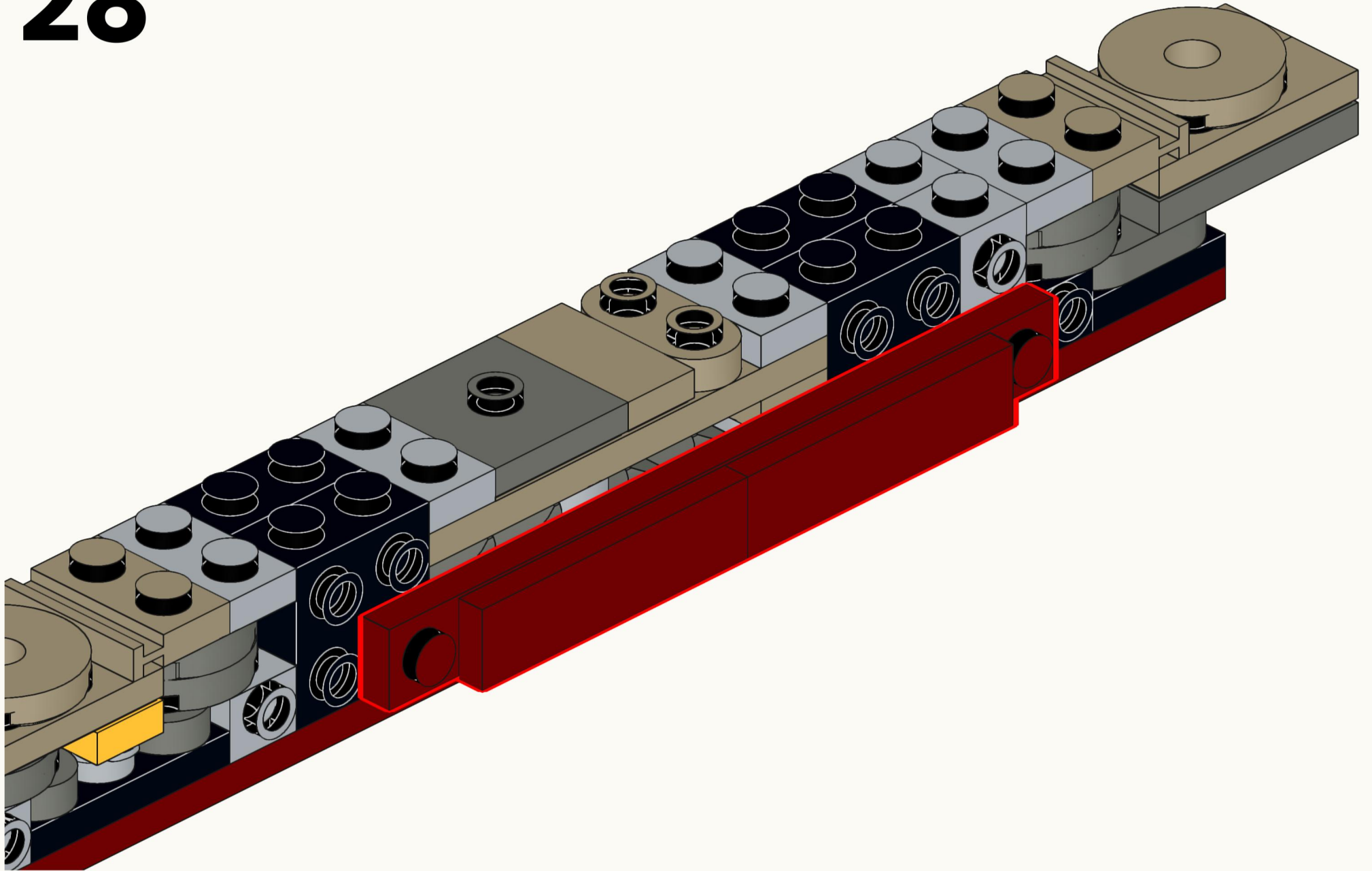

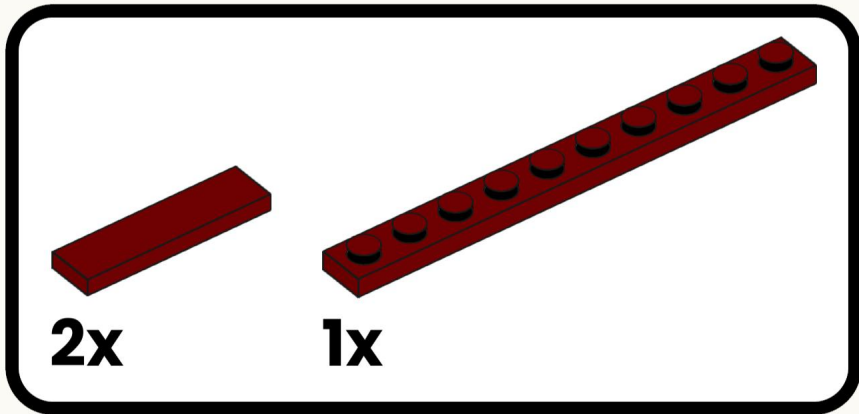
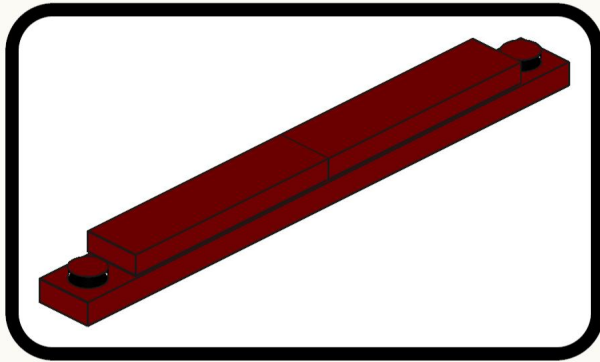

30

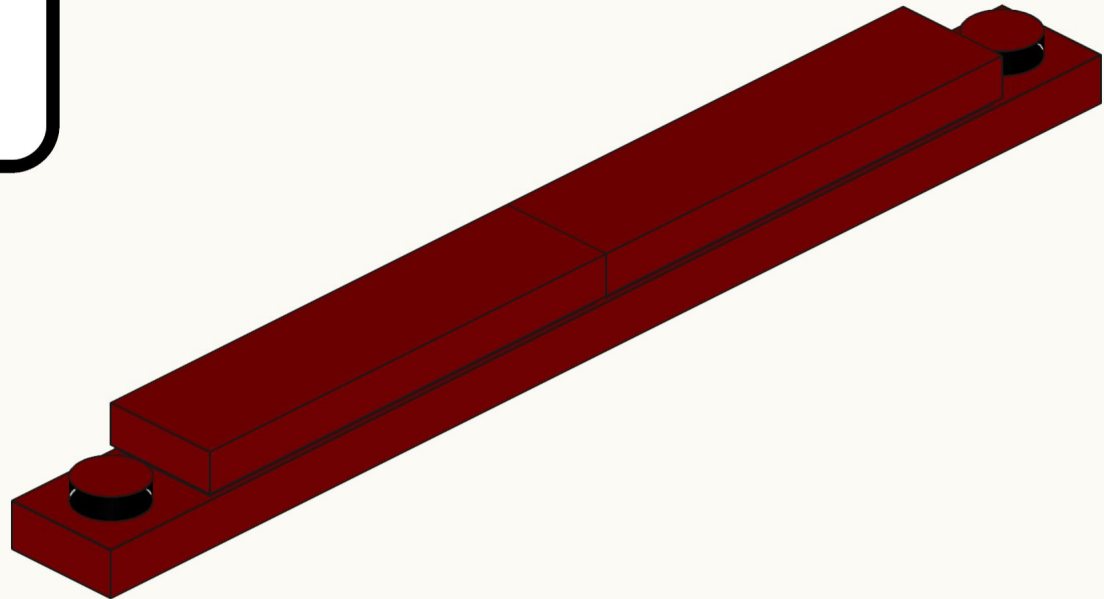

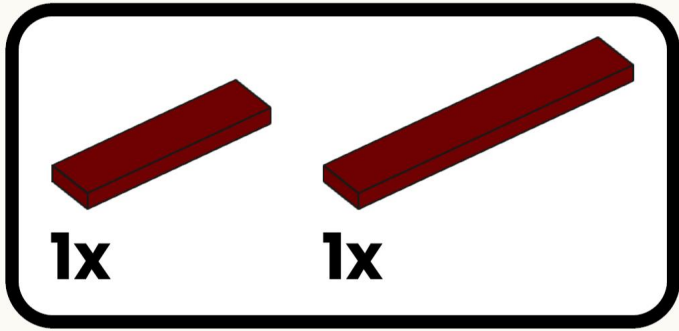

32

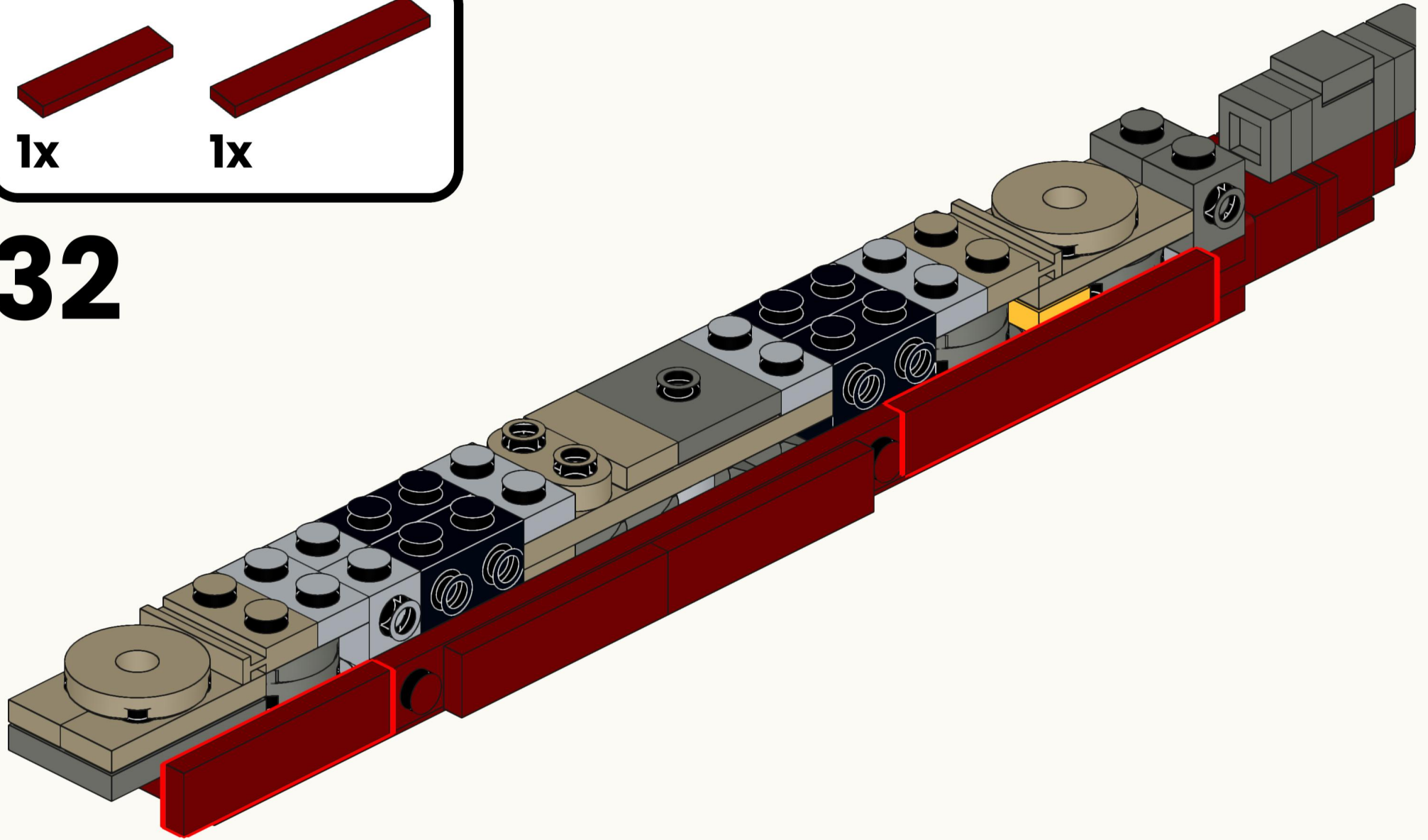

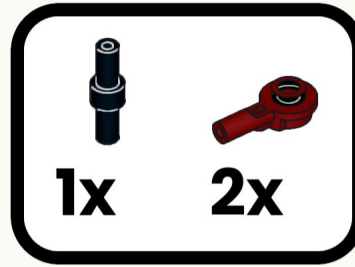
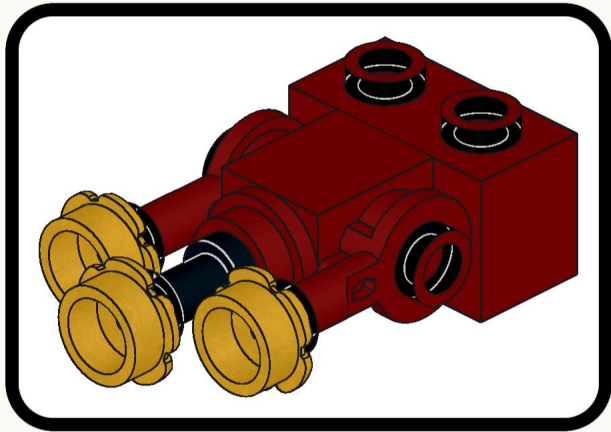

34

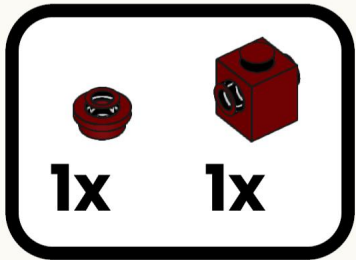

33

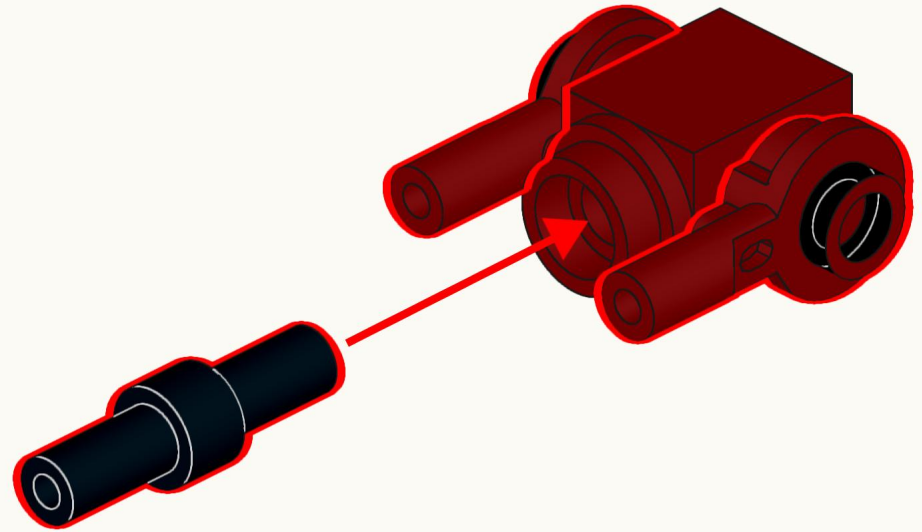
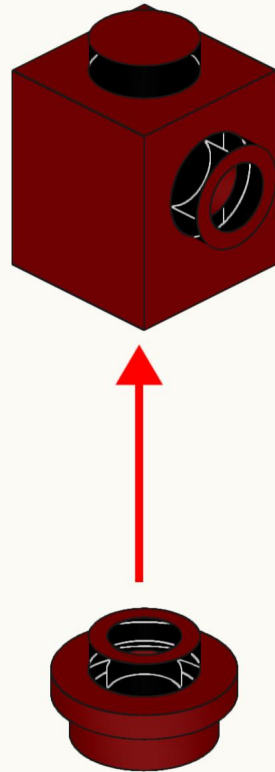



35

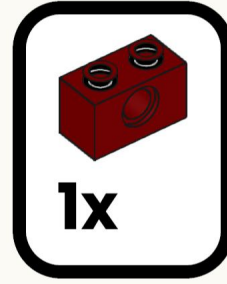
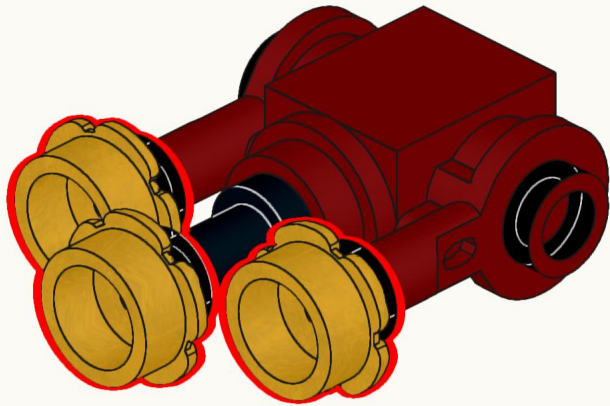

36

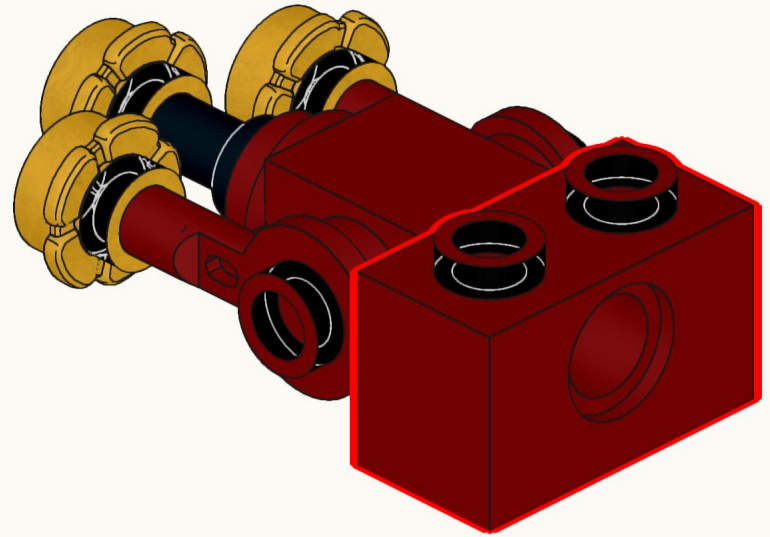

37

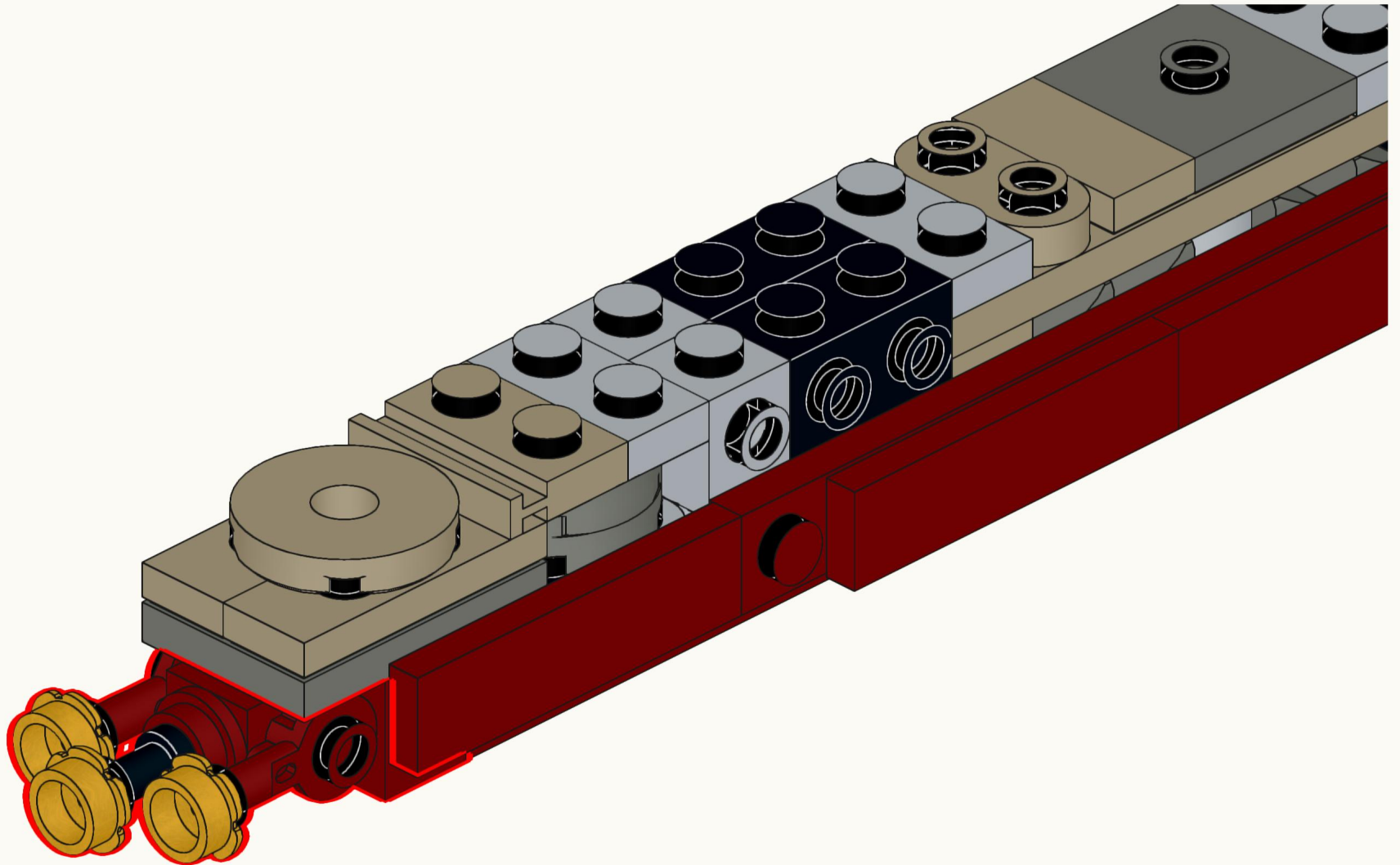

Unlike Bismarck which used Blohm & Voss turbines, Tirpitz was powered by Brown, Boveri & Cie geared steam turbines. It used the same triple-shaft arrangement but produced 160,793 shaft horsepower — notably more than Bismarck's 150,170.

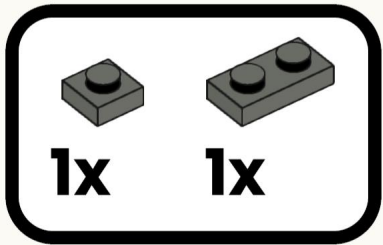
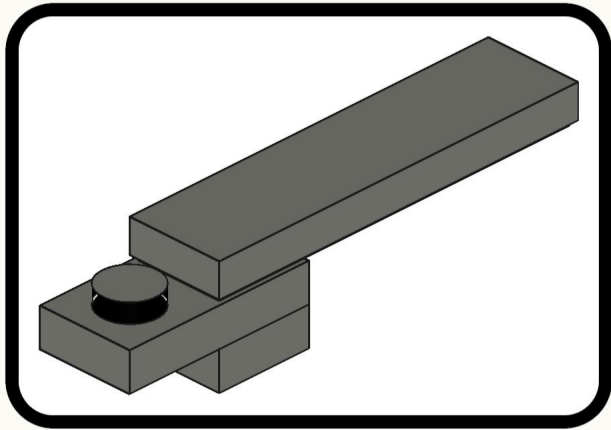

38

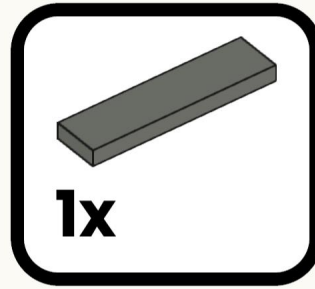
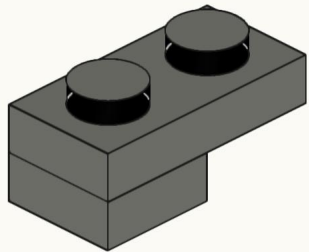

39

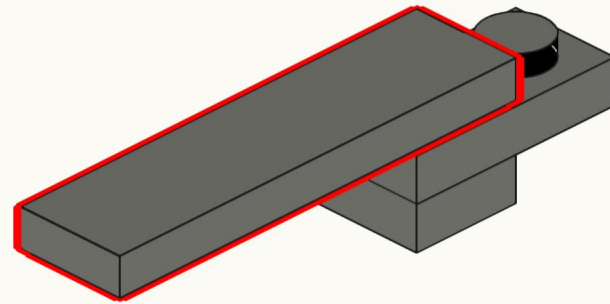

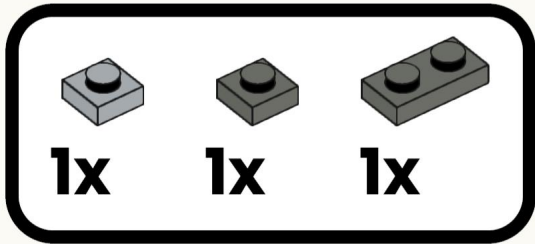
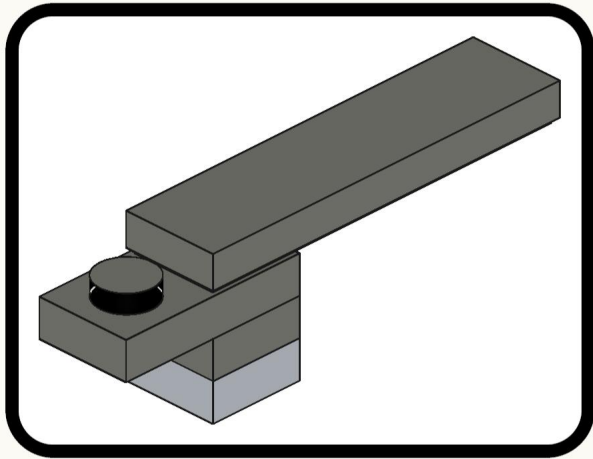

41

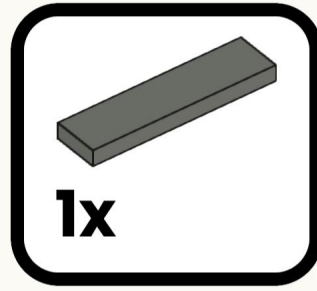
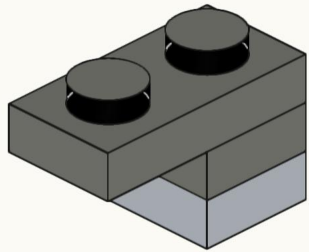

42

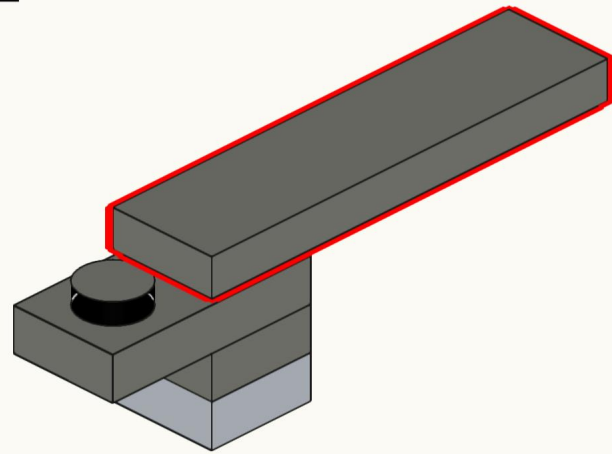

43

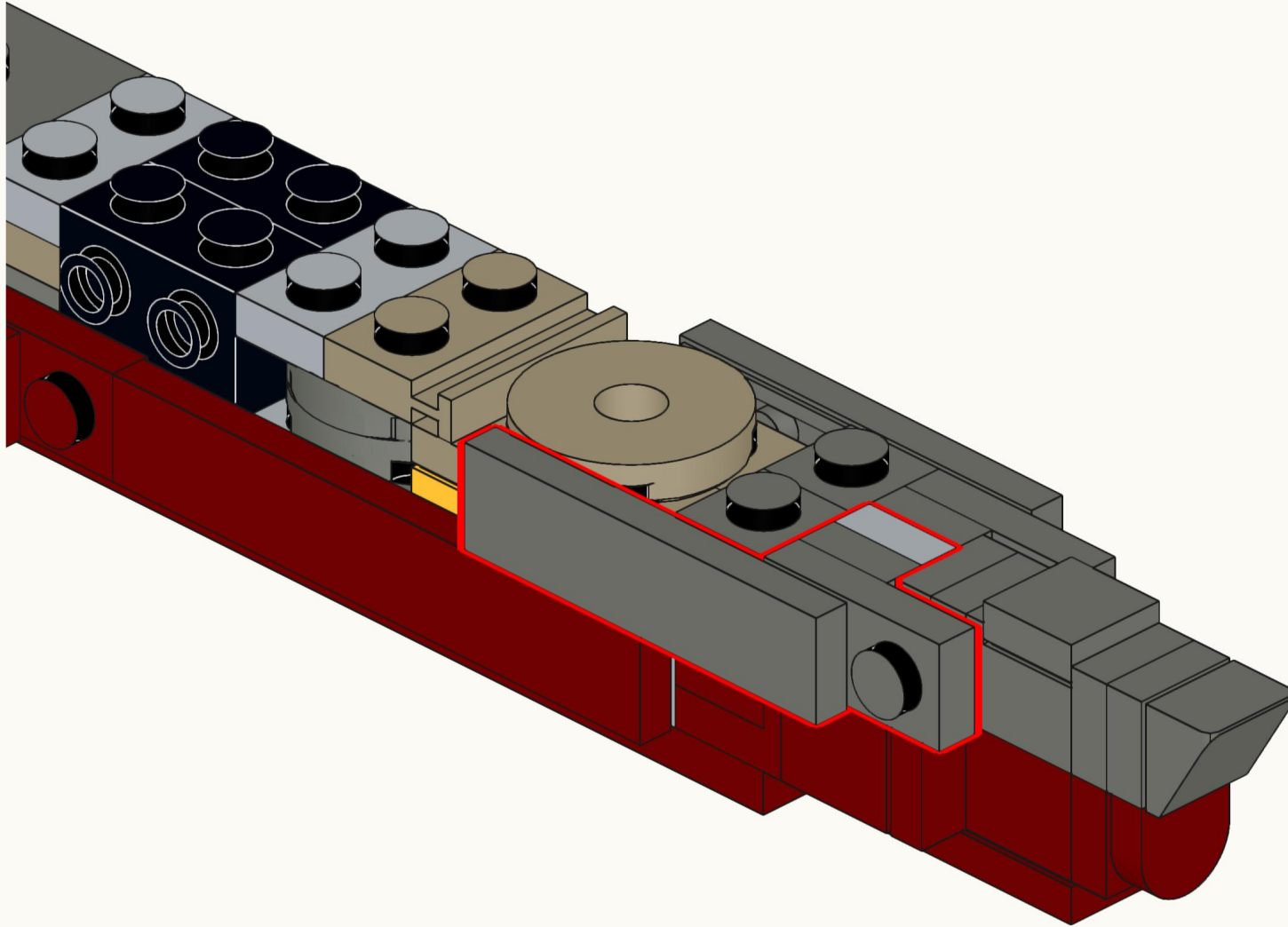

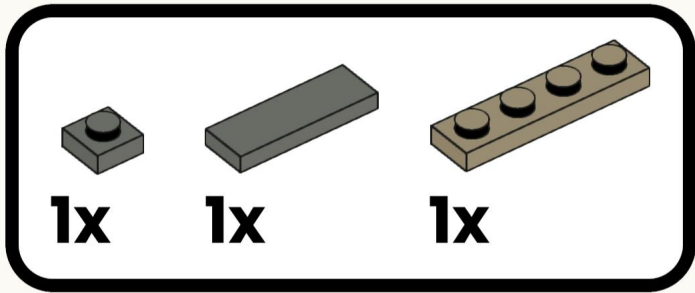

44

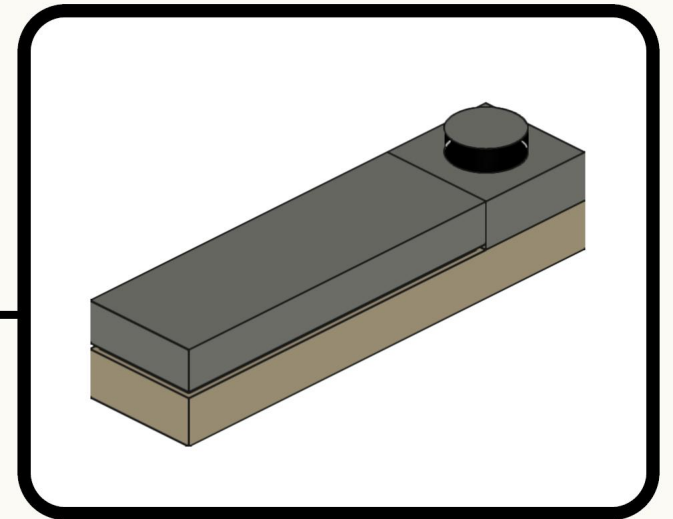
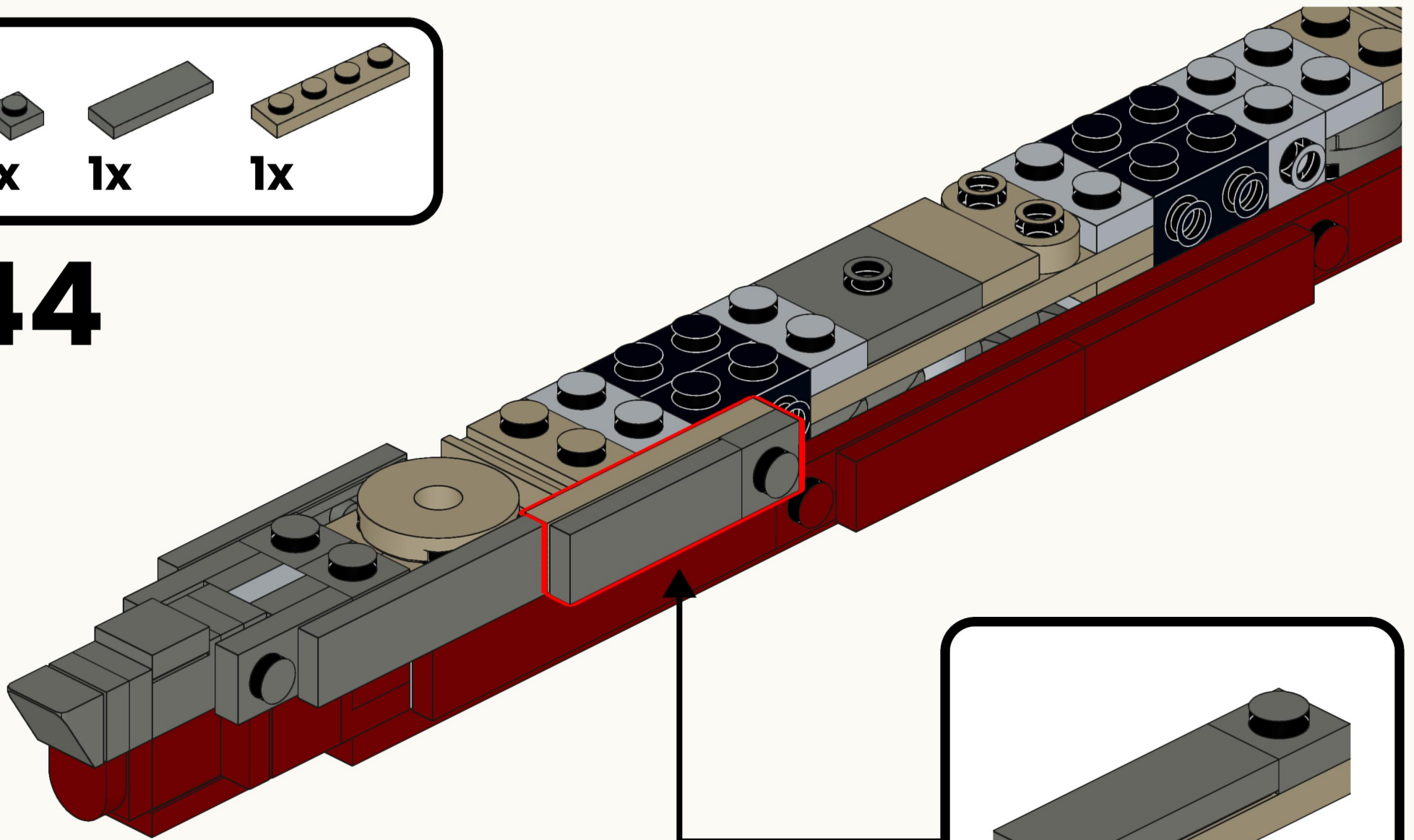



1x 1x 1x

A callout box containing three items: a small grey 1x1 brick with a hole, a grey 1x3 Technic brick, and a tan 1x3 Technic brick with three holes. Each item is accompanied by the text "1x".

45

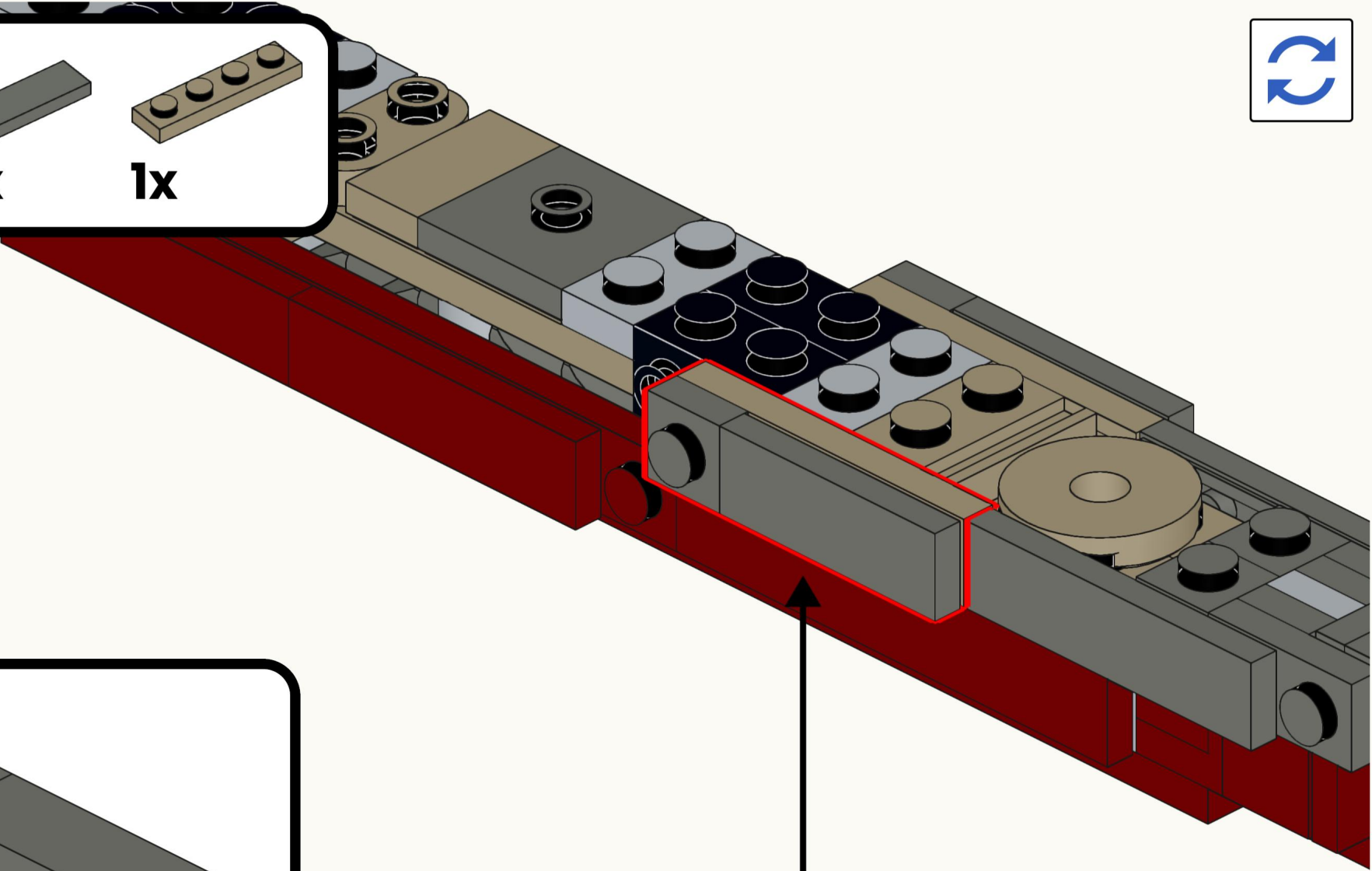
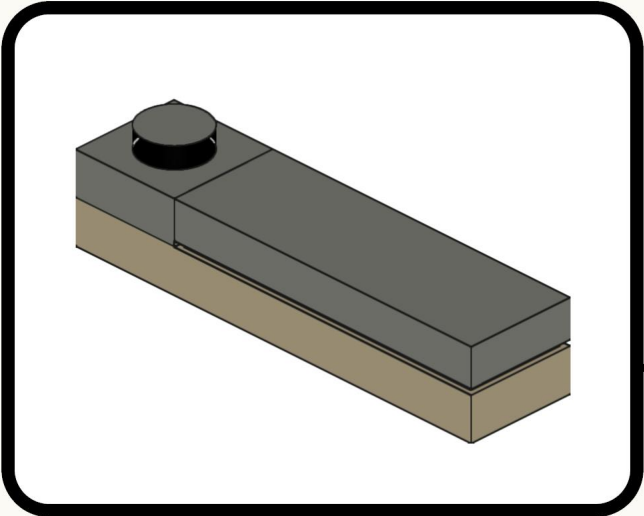

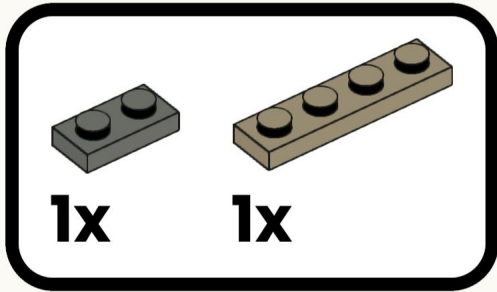
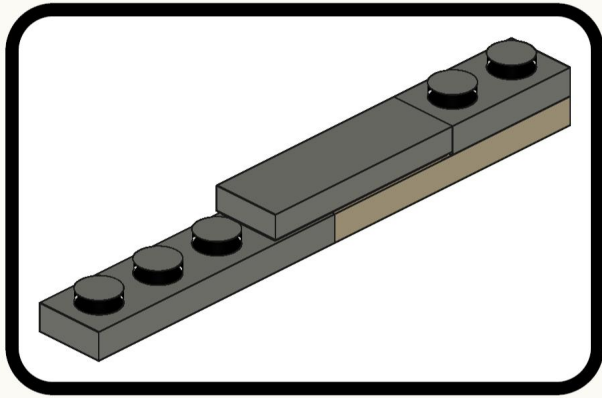

46

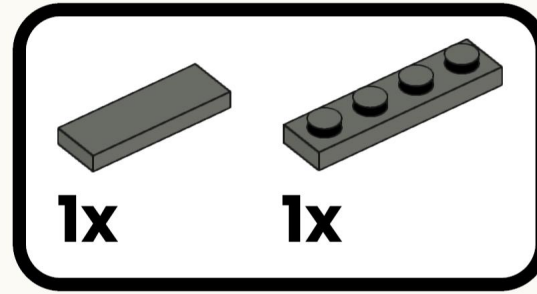
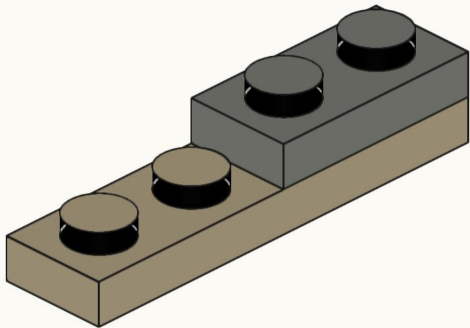

47

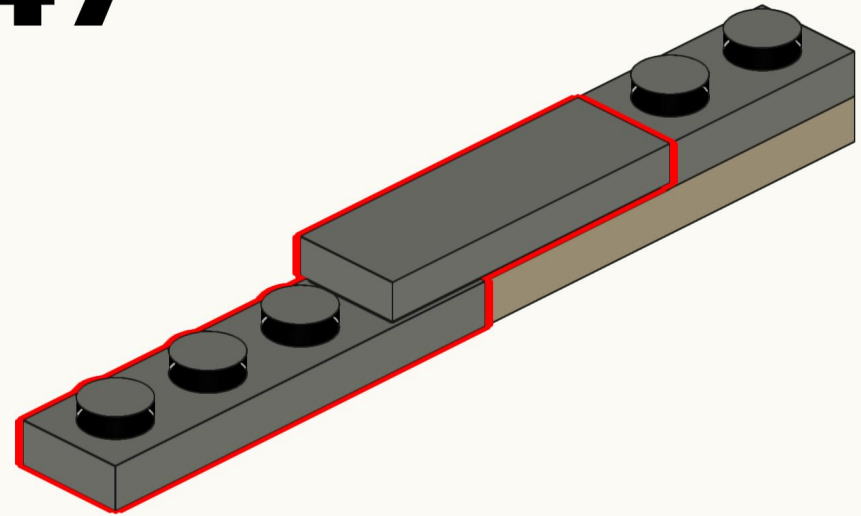

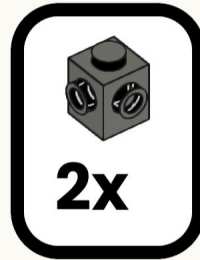
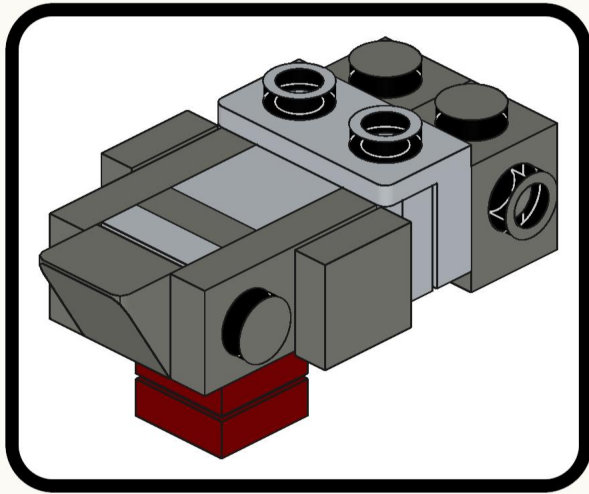

50

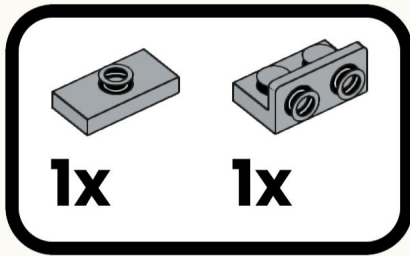

49

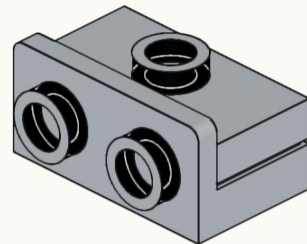
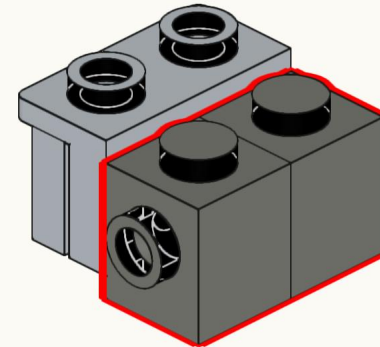

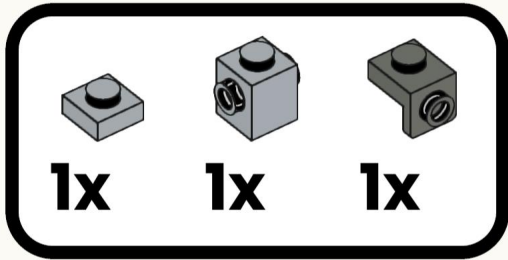

51

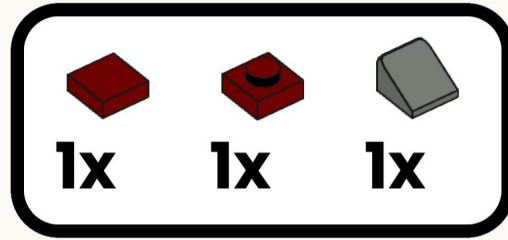
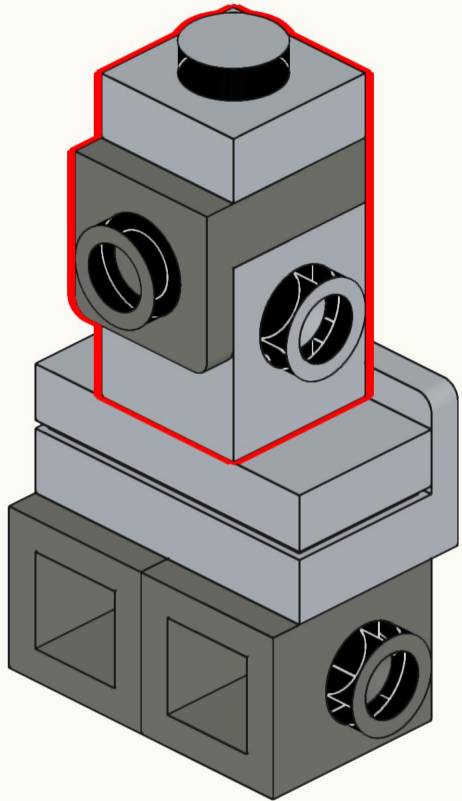

52

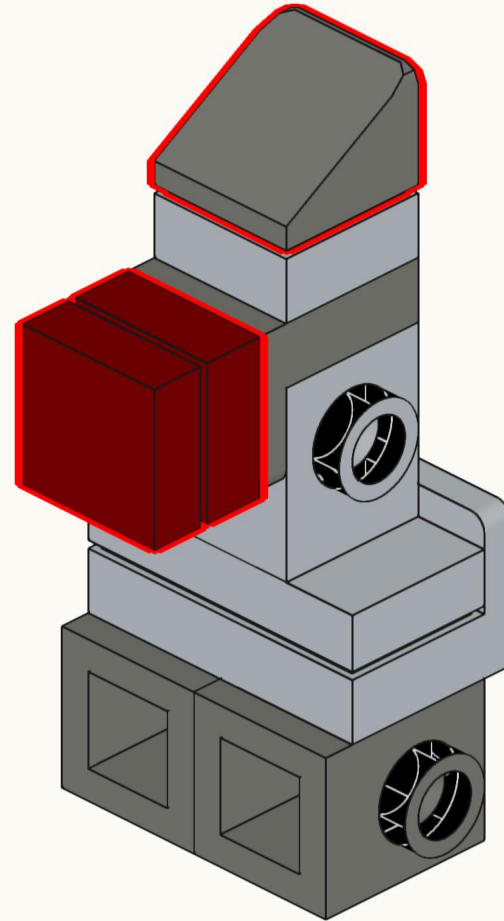

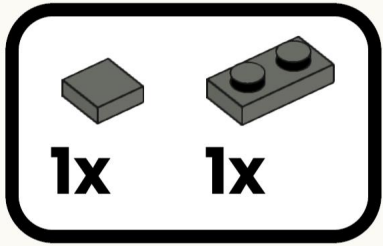

53

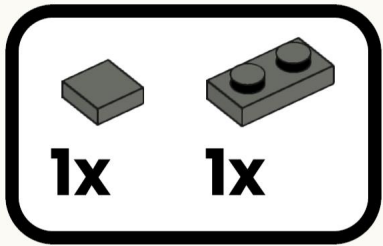
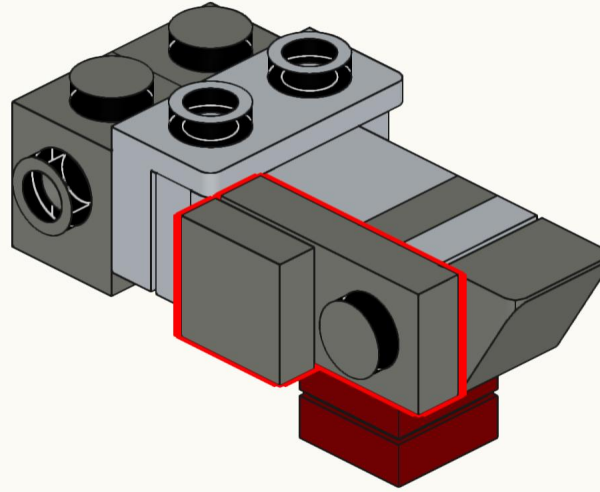

54

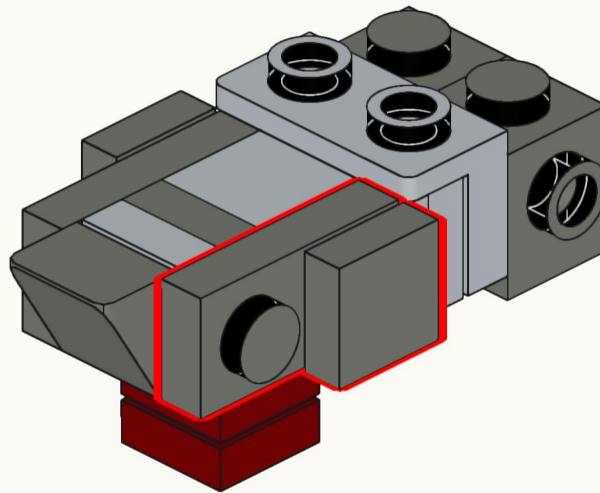

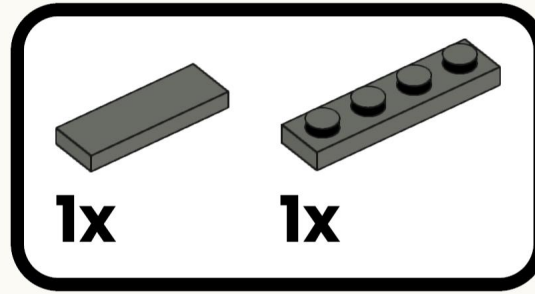
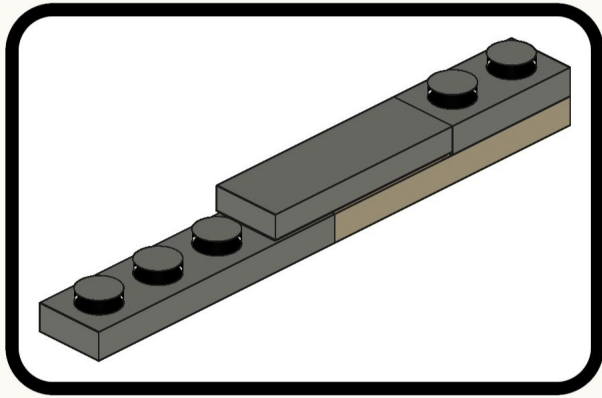

57

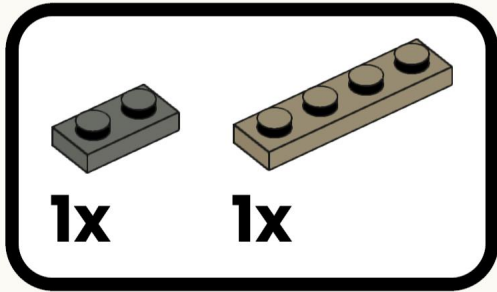

56

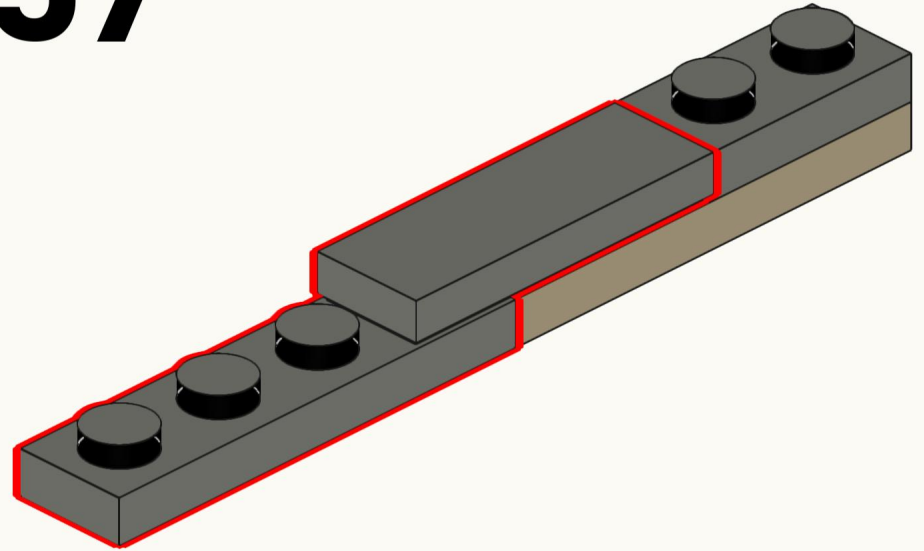
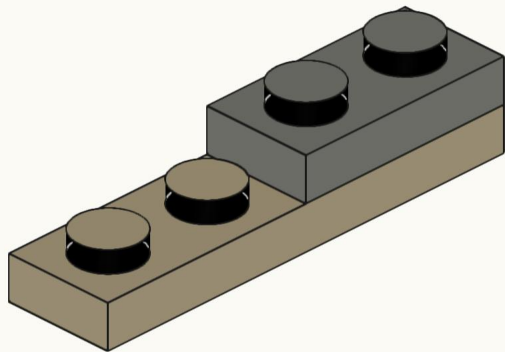

58

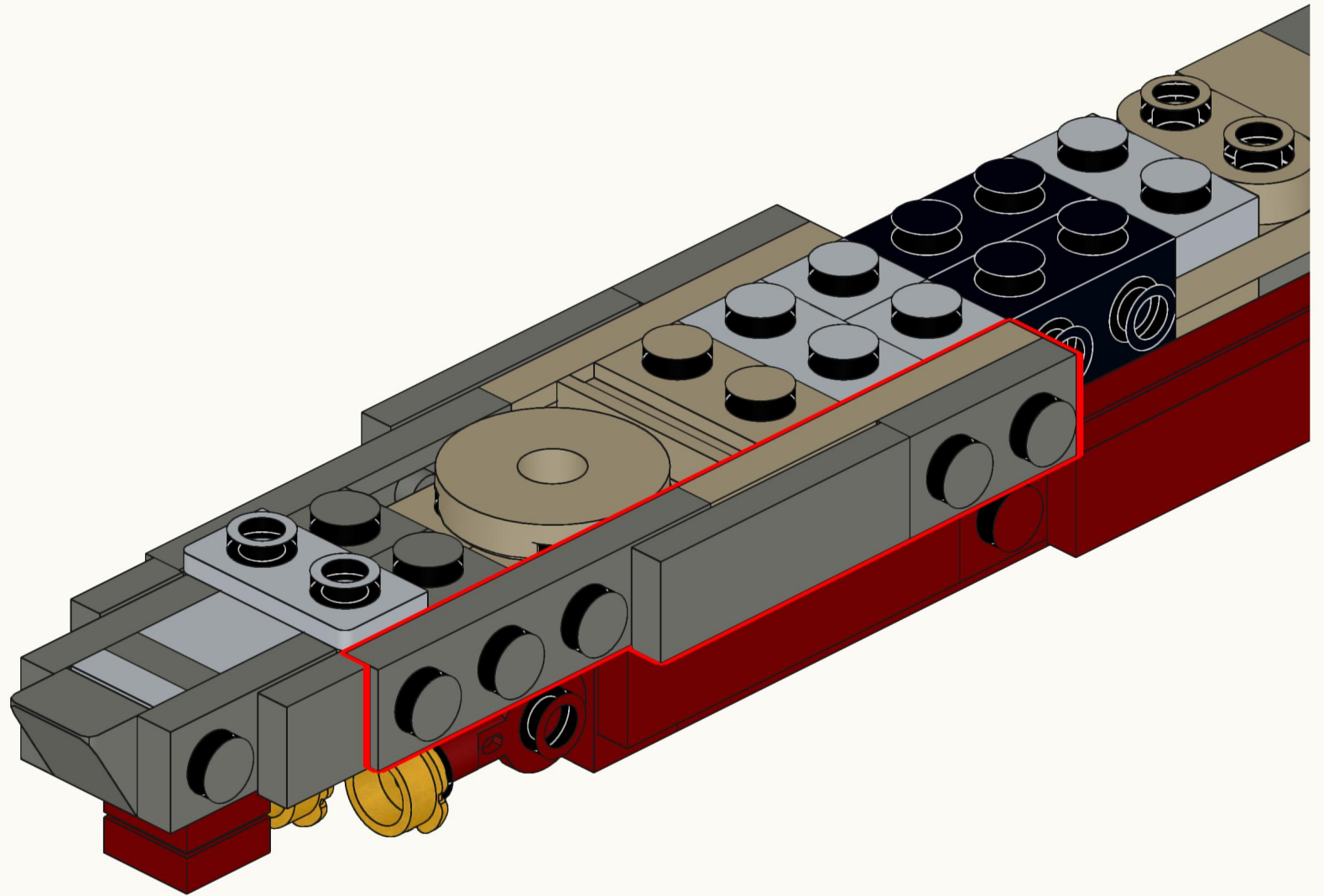

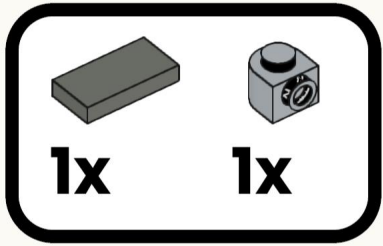

59

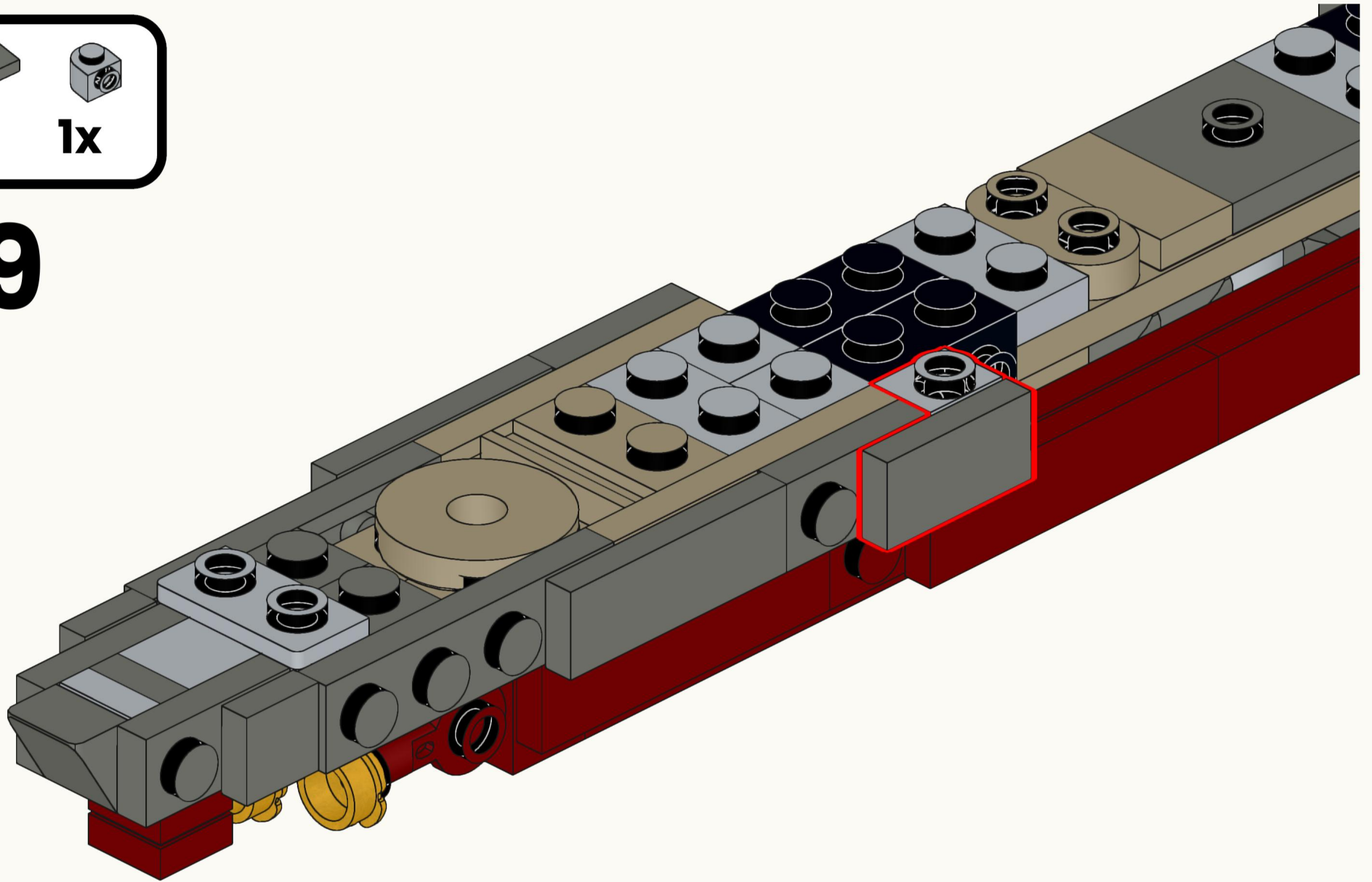

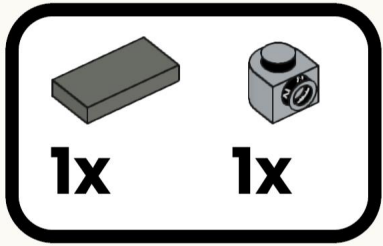

60

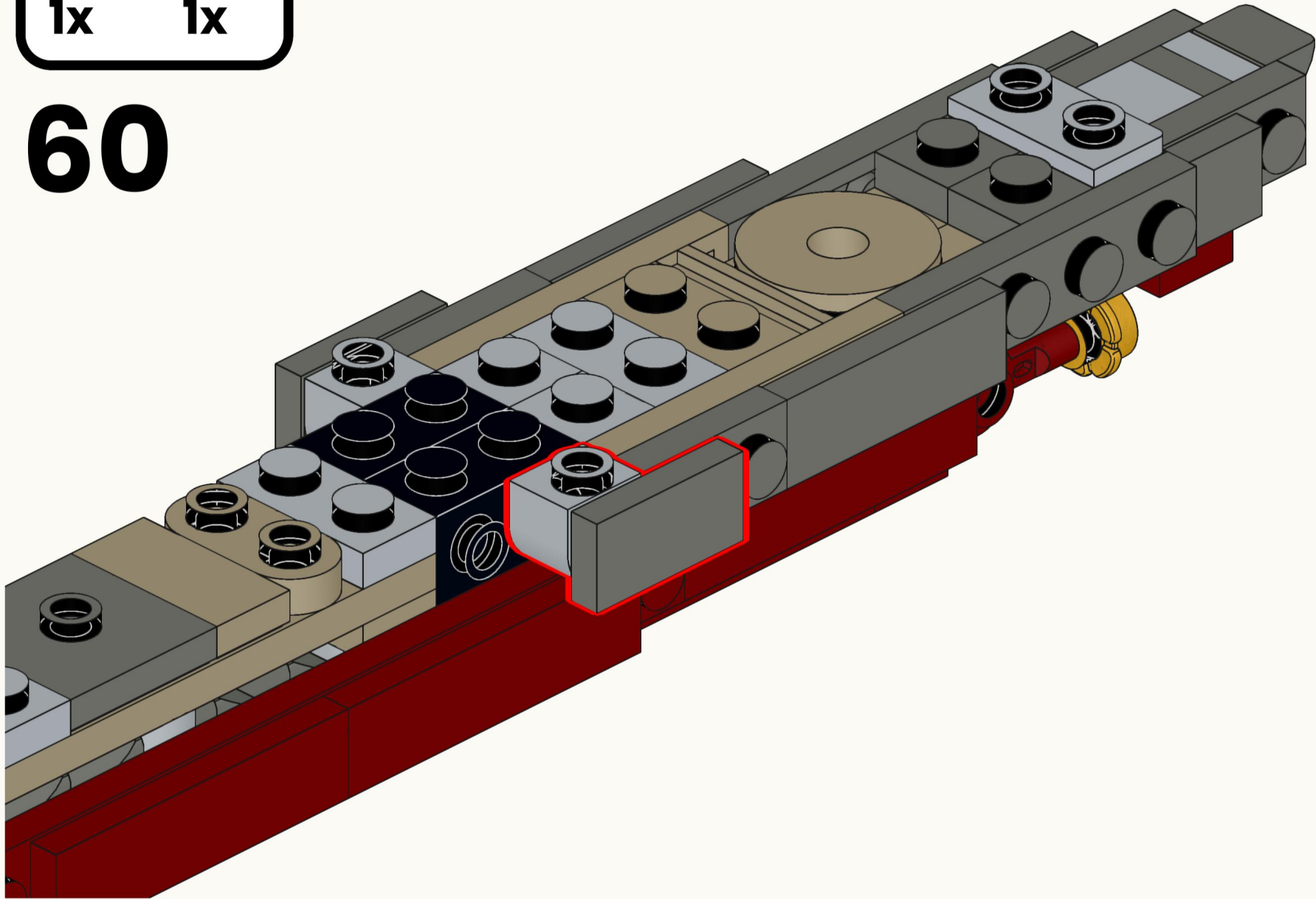

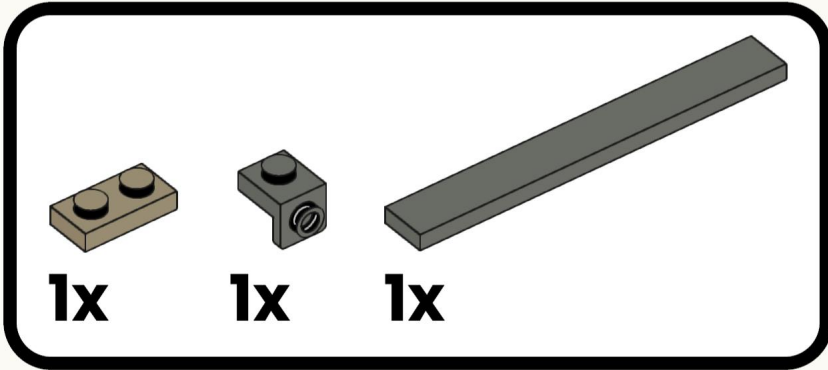
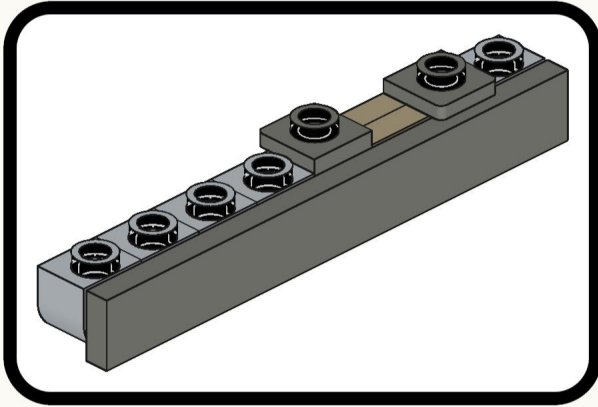

61

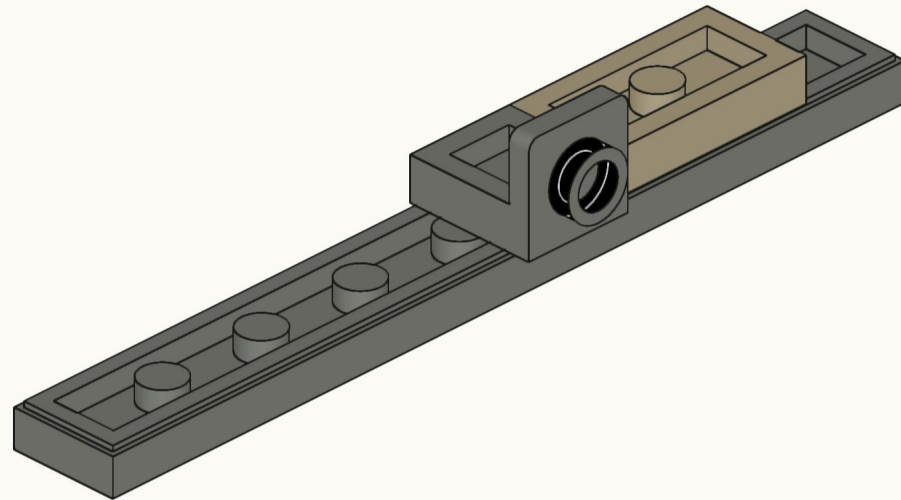

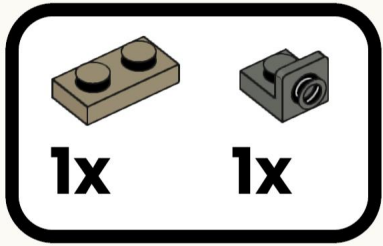

62

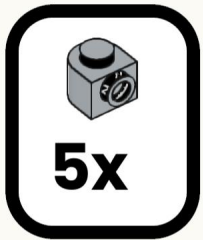
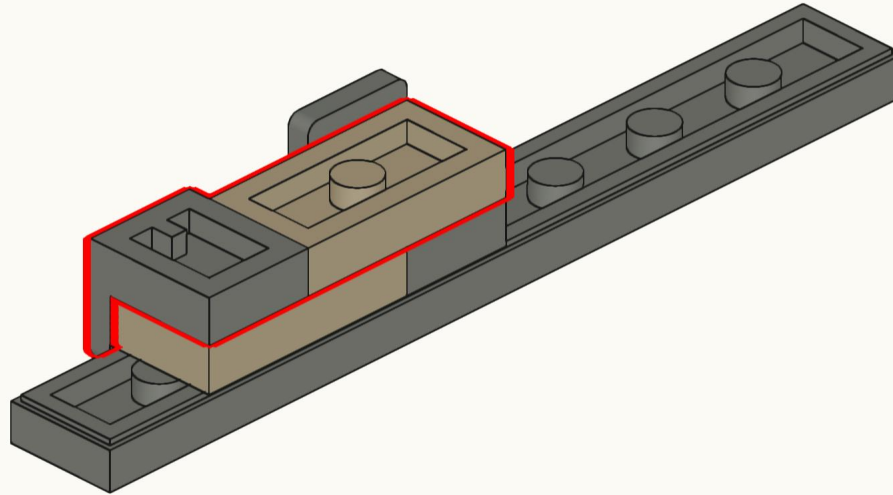

63

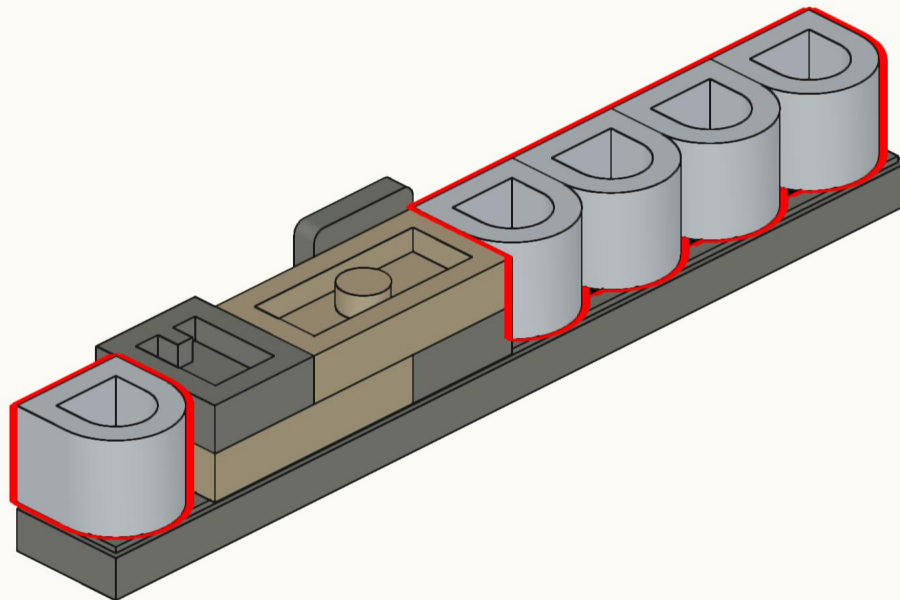

64

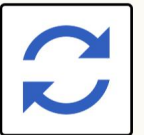
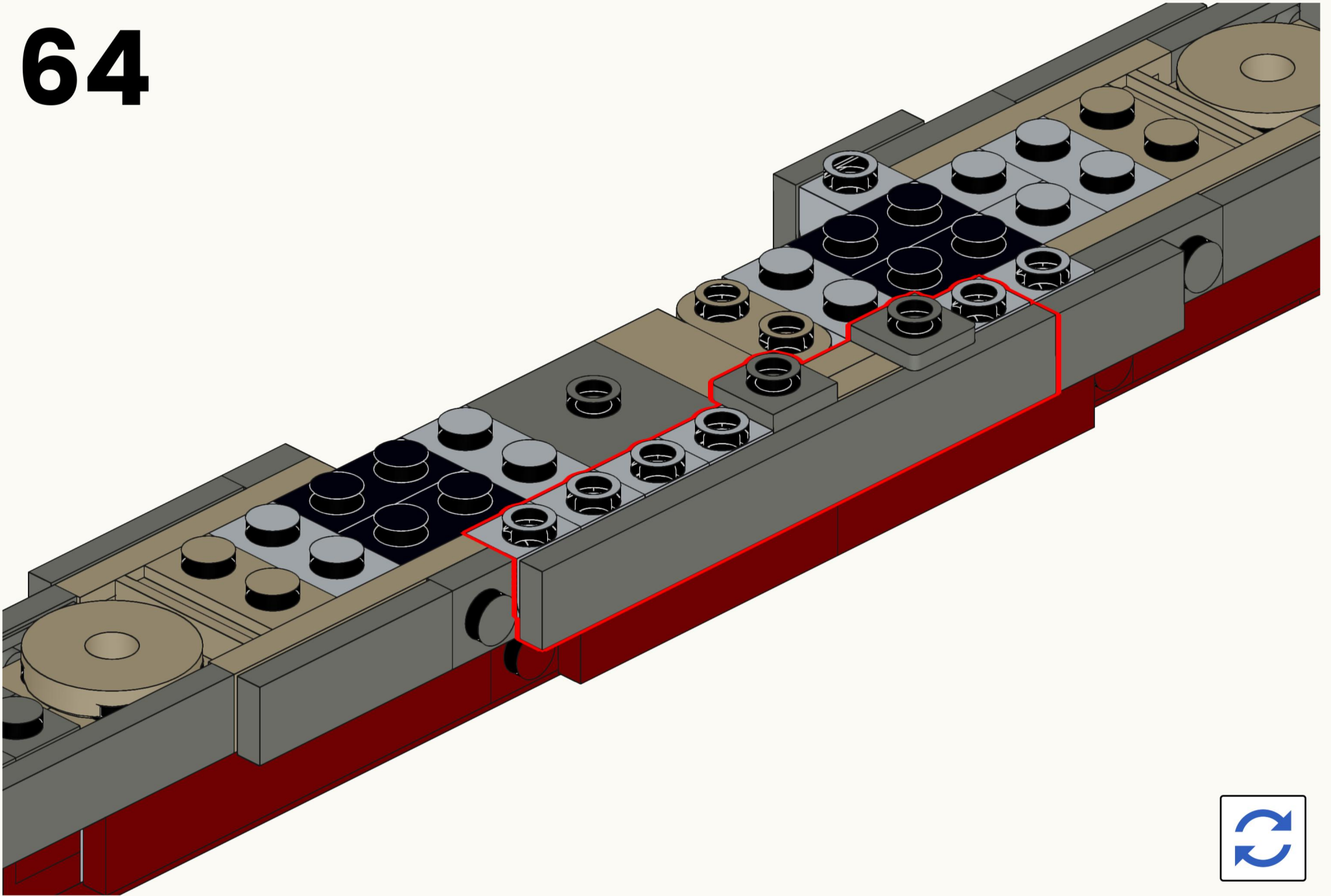

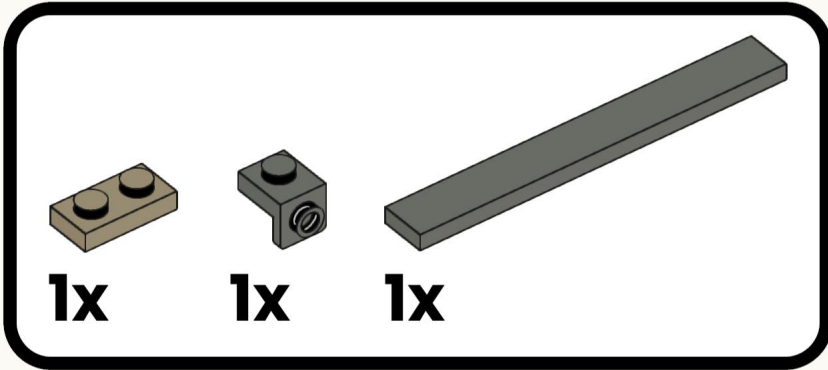
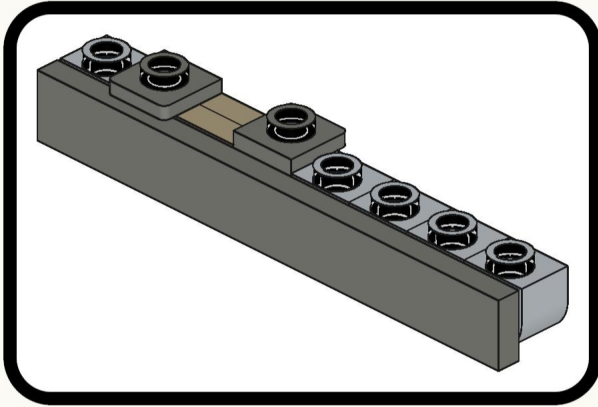

65

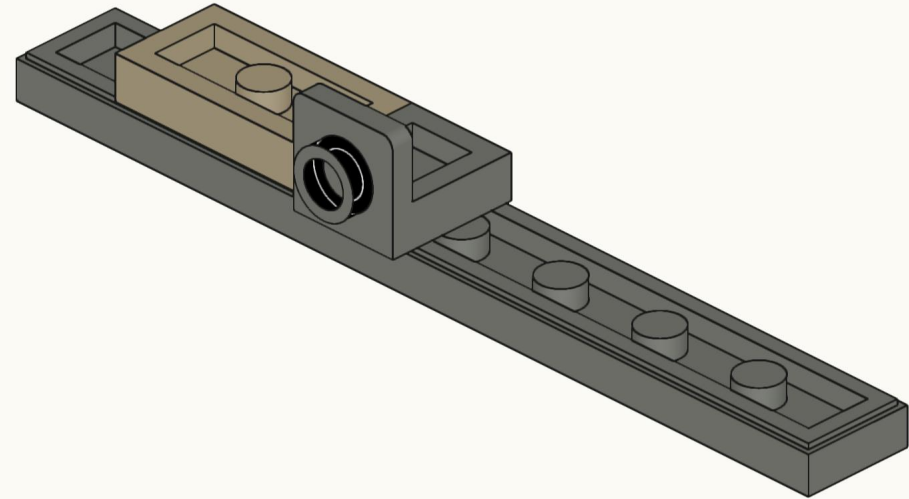

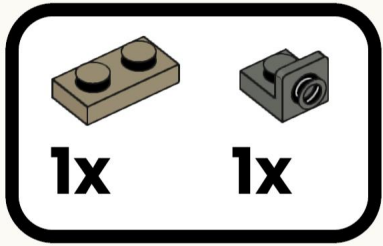

66

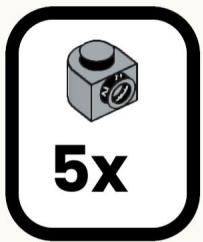
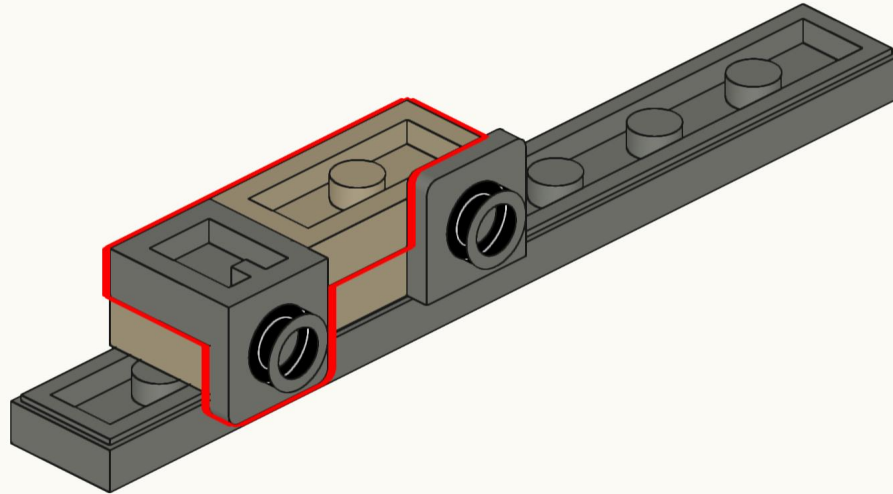

67

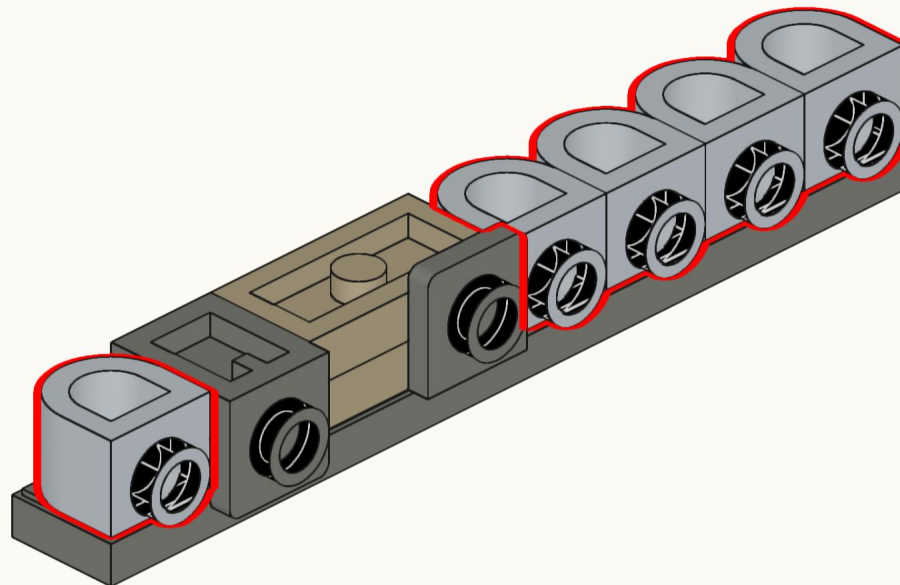

68

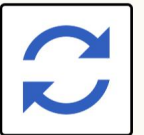
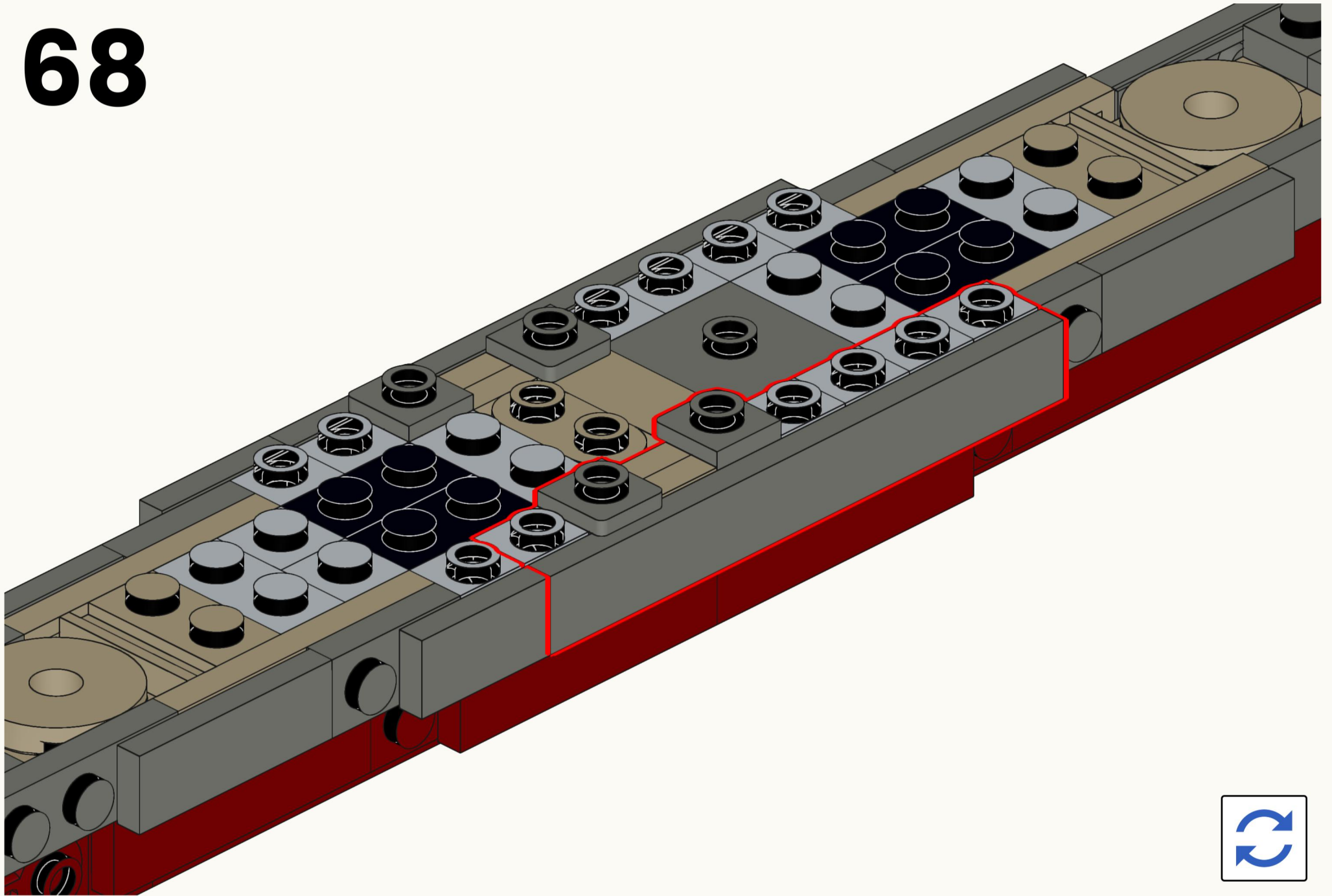

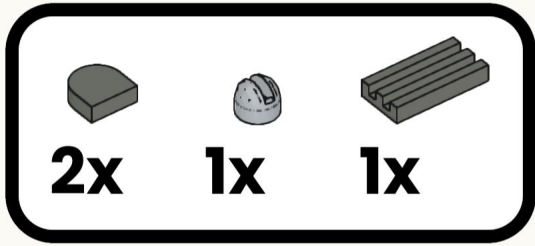

69

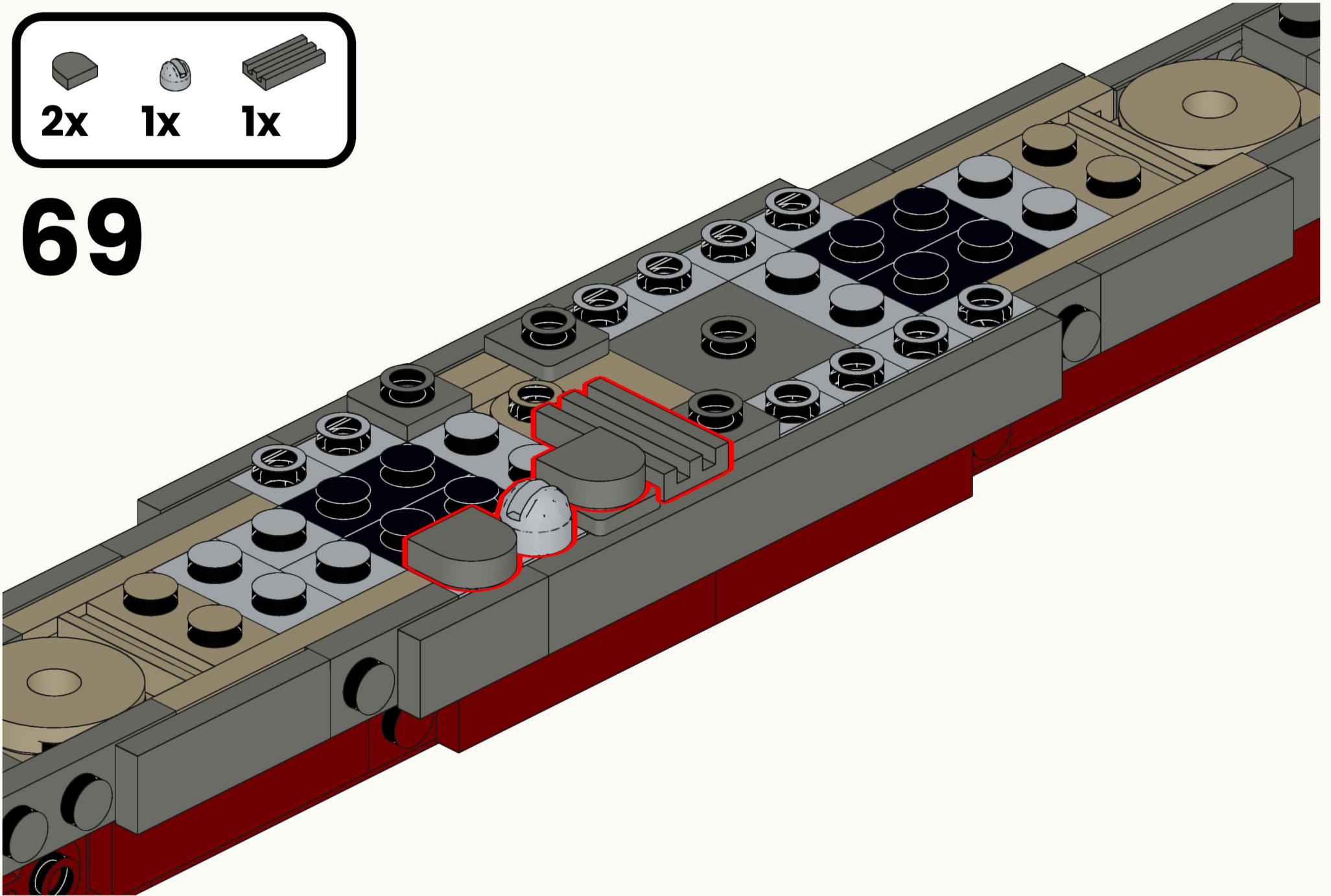

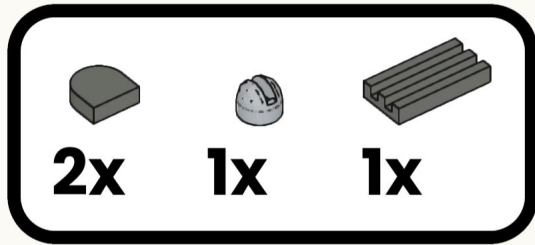

70

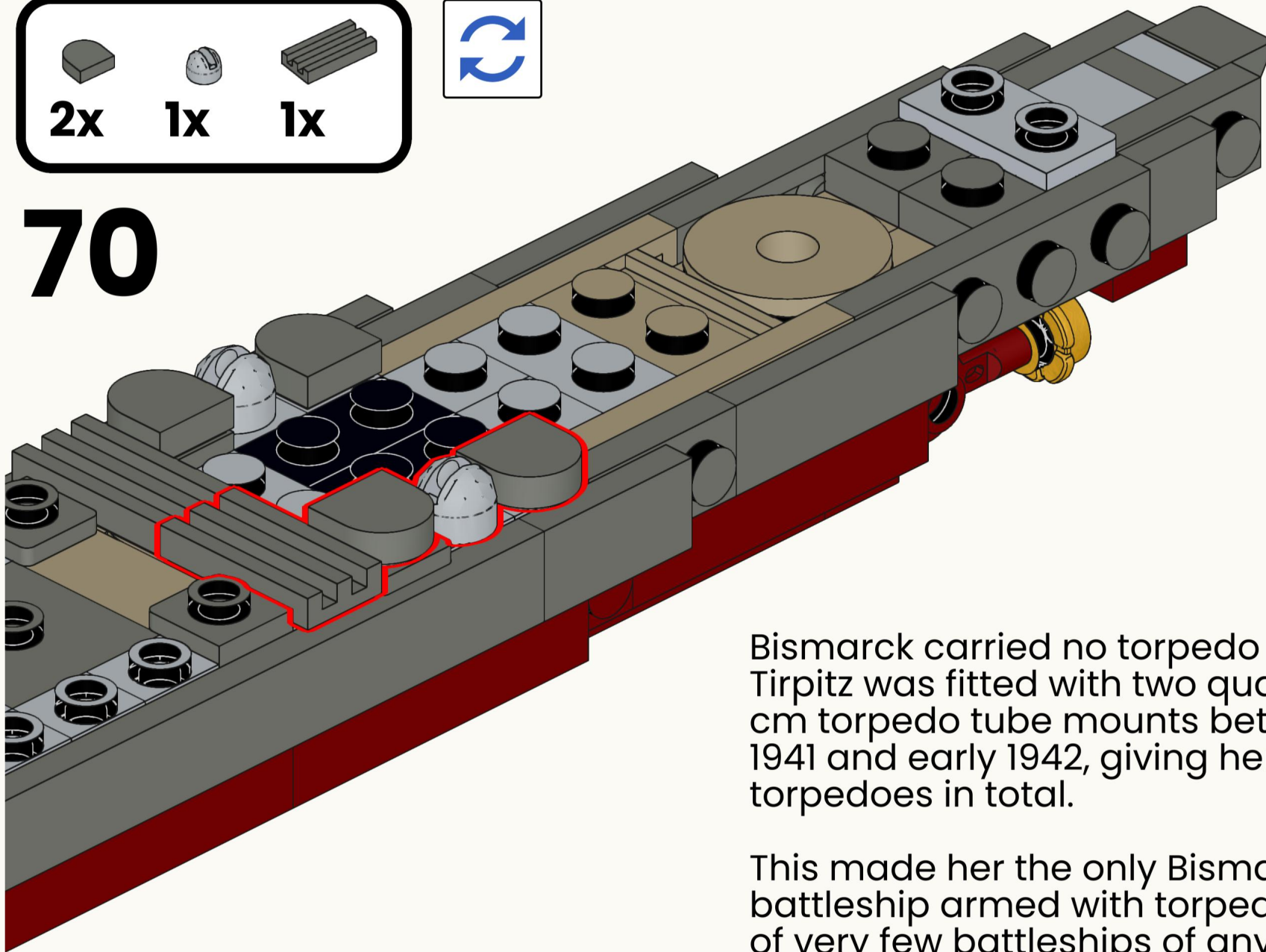

Bismarck carried no torpedo tubes, but Tirpitz was fitted with two quadruple 53.3 cm torpedo tube mounts between late 1941 and early 1942, giving her 24 torpedoes in total.

This made her the only Bismarck-class battleship armed with torpedoes and one of very few battleships of any navy to carry them alongside a full main battery.

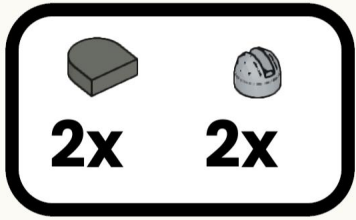

72

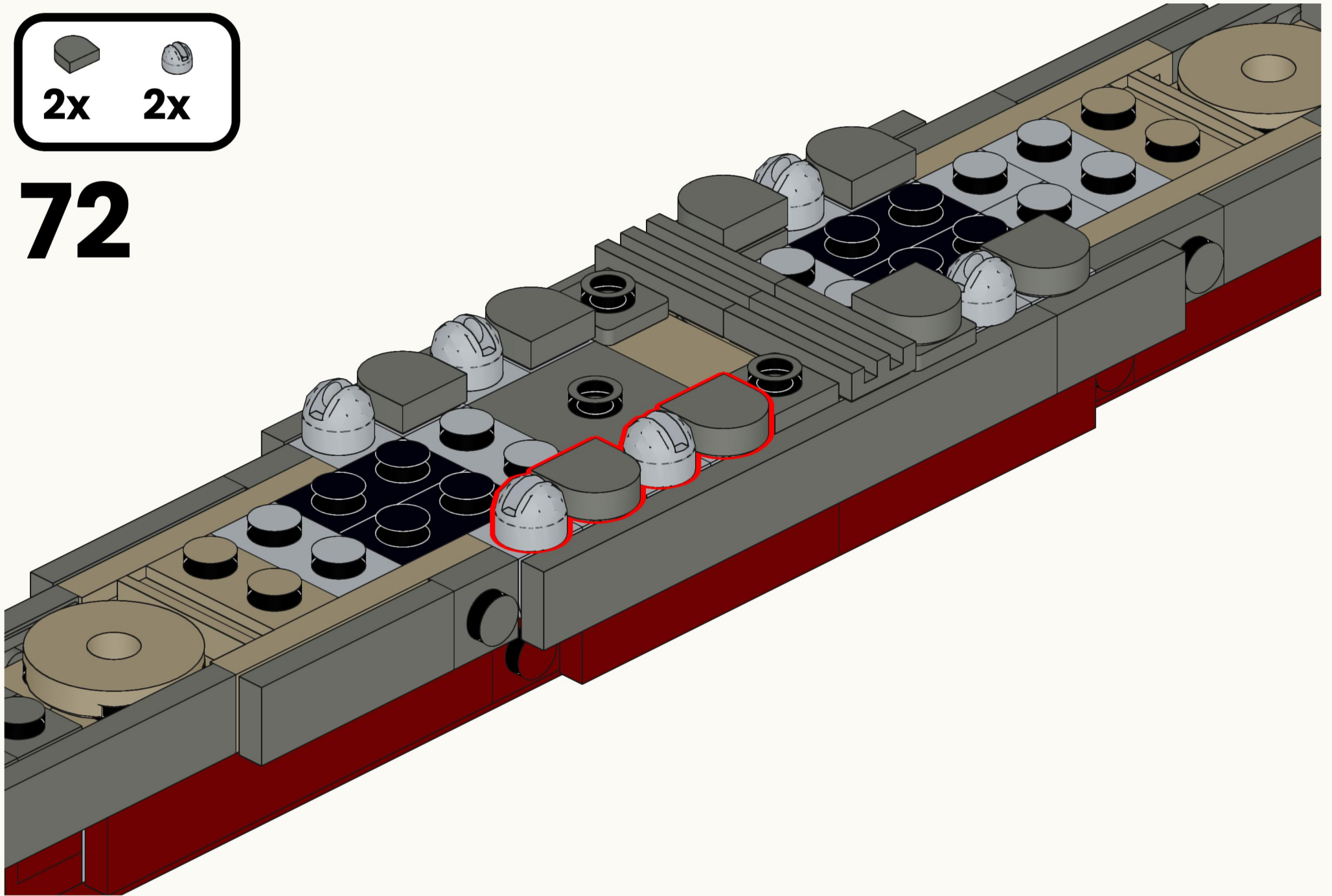

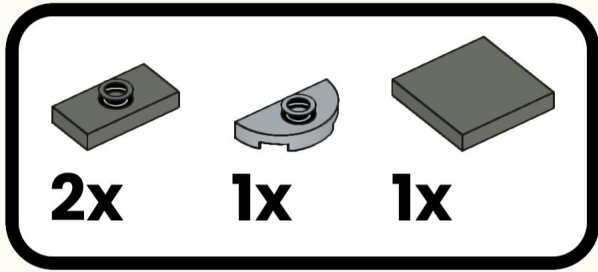

2x 1x 1x

This block contains three small images of LEGO parts: a grey 1x2 Technic brick with a hole, a grey 1x2 Technic Technonut, and a grey 1x2 Technic Technonut. Below each image is a quantity label: '2x' for the brick, '1x' for the Technonut, and '1x' for the Technonut.

73

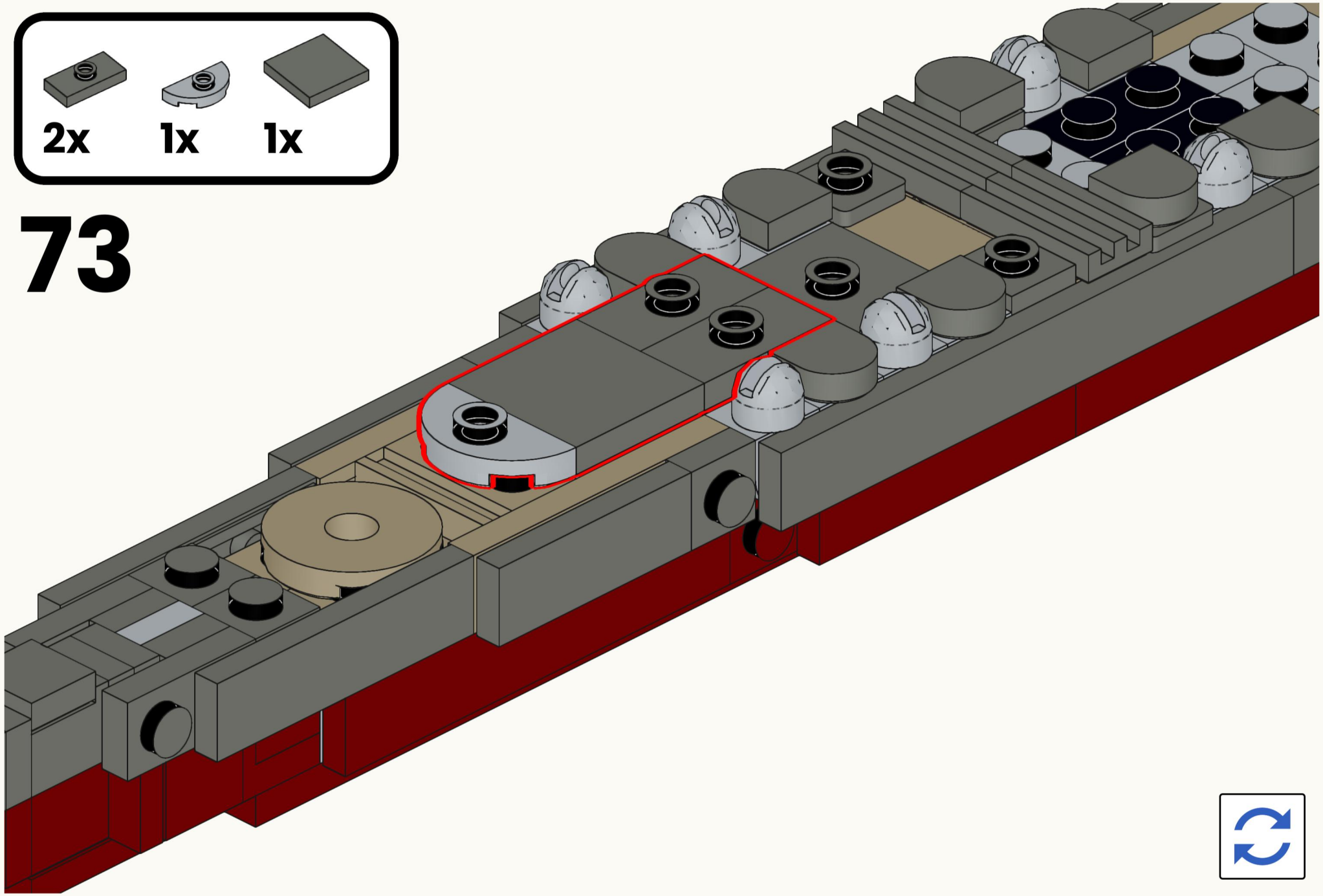

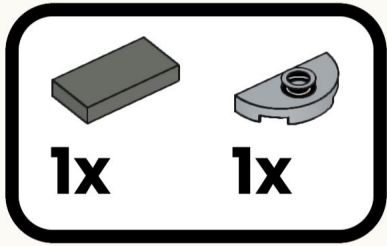

74

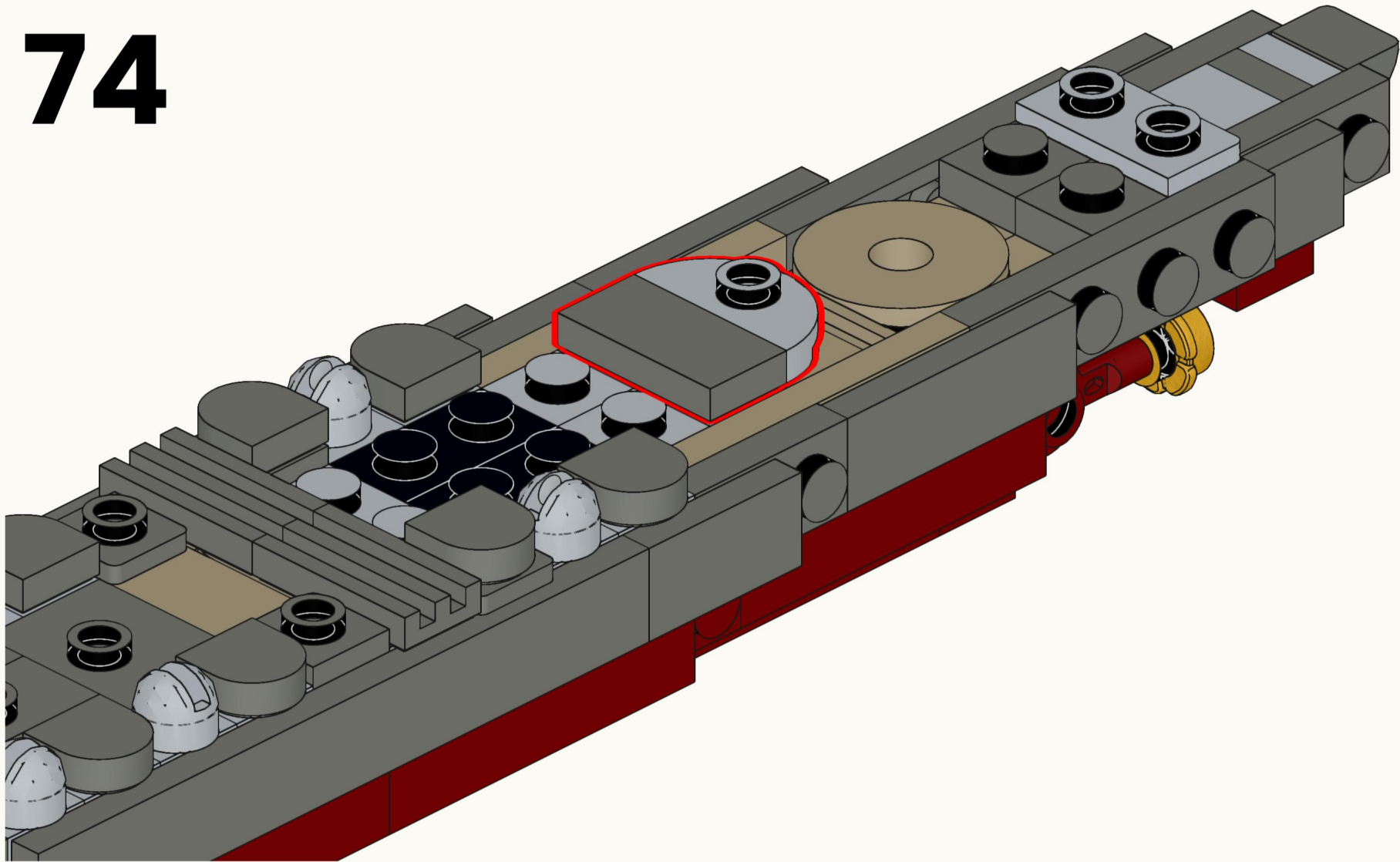

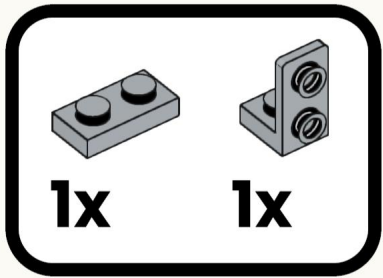
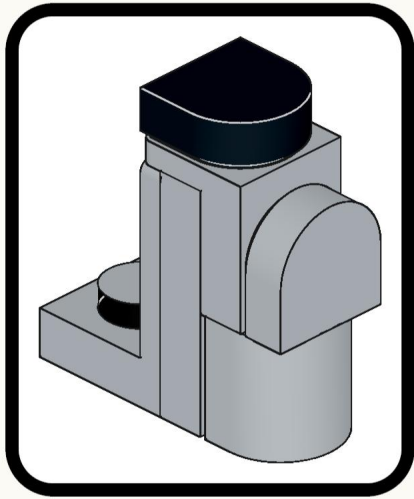

75

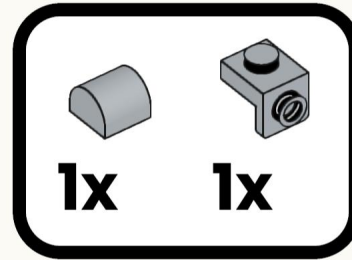
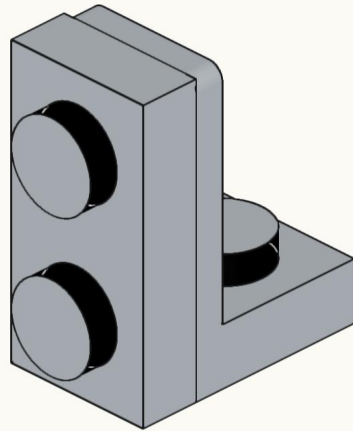

76

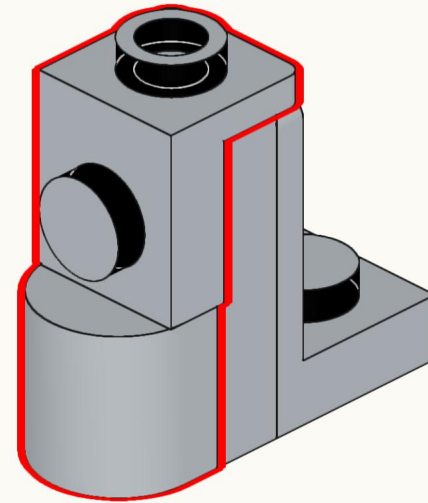

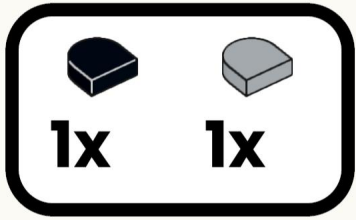

77

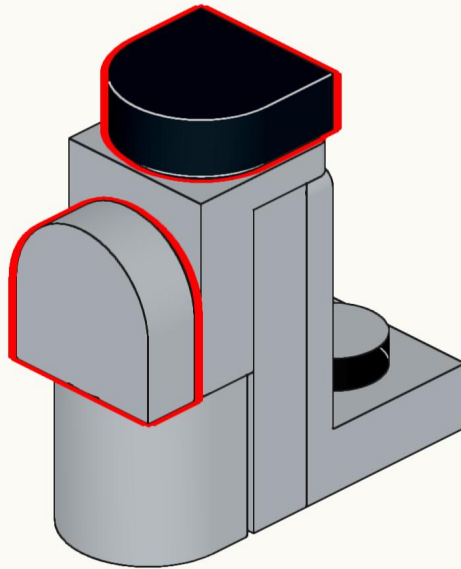

78

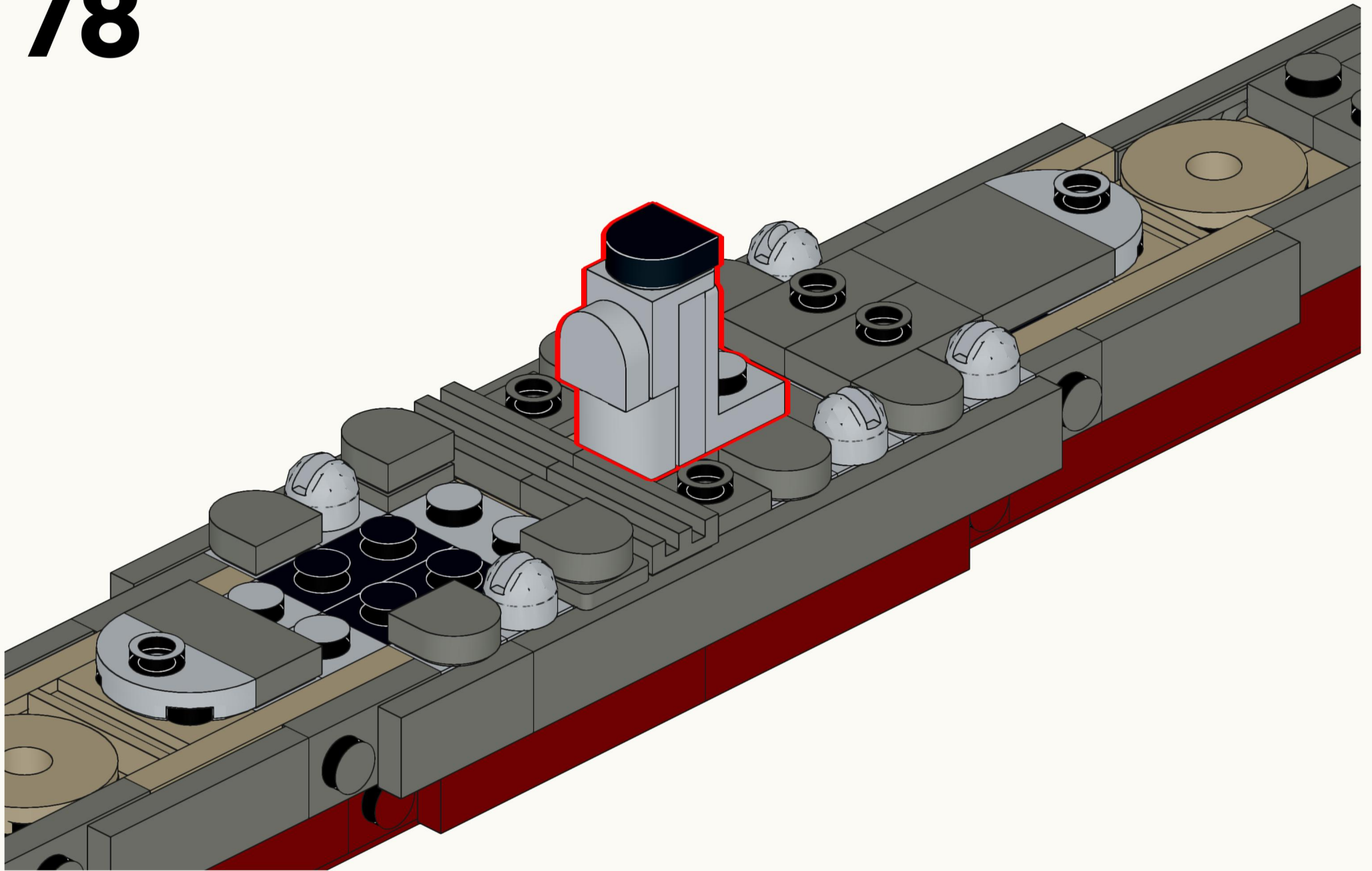

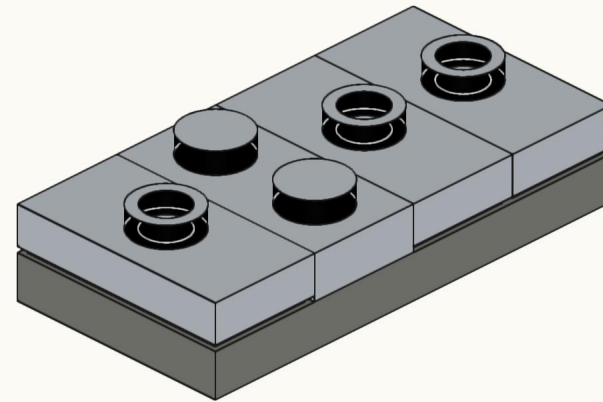
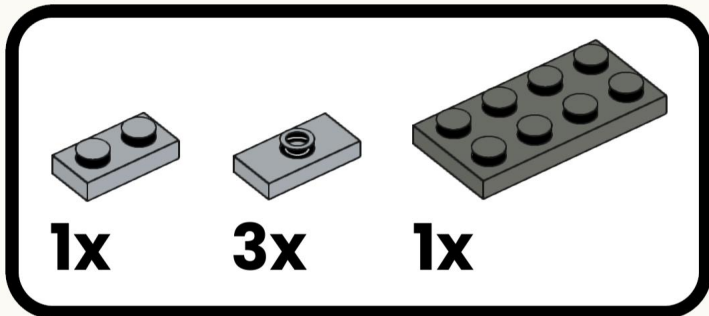
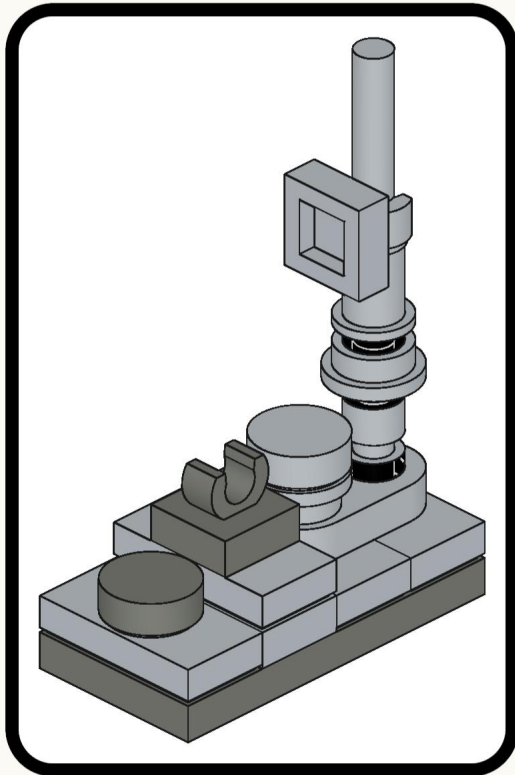

79

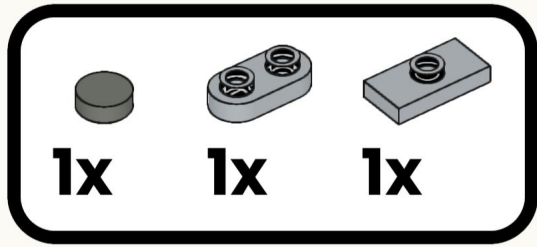

80

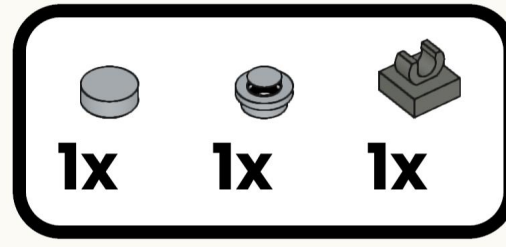
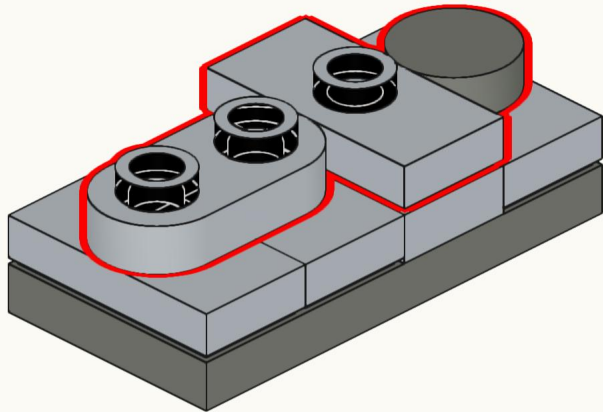

81

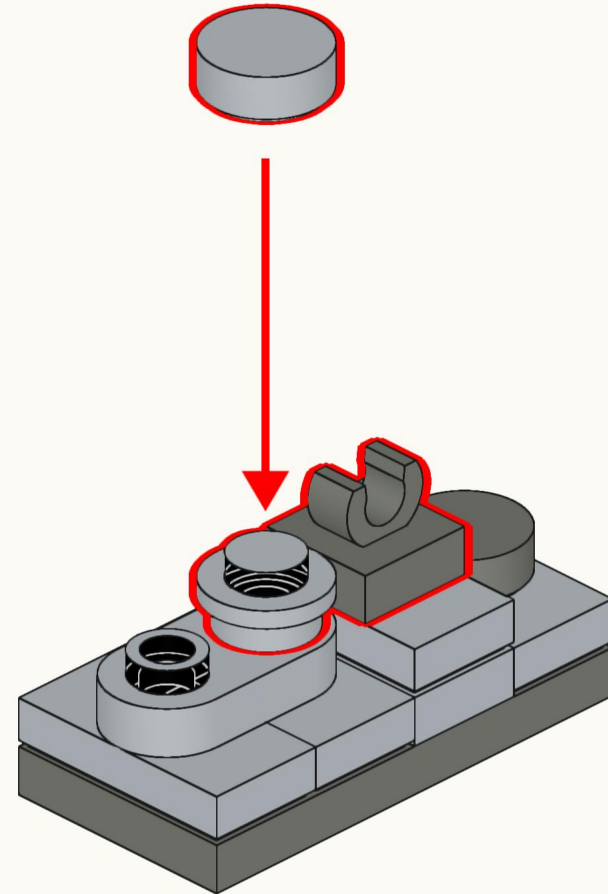

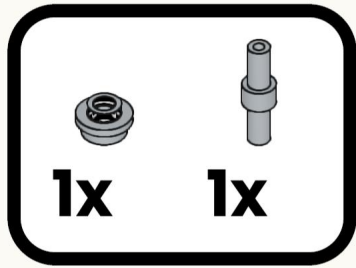

82

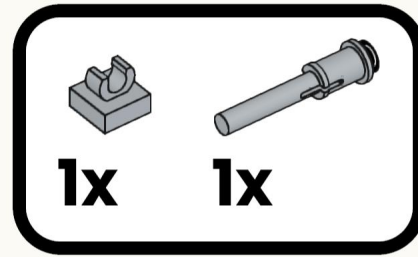
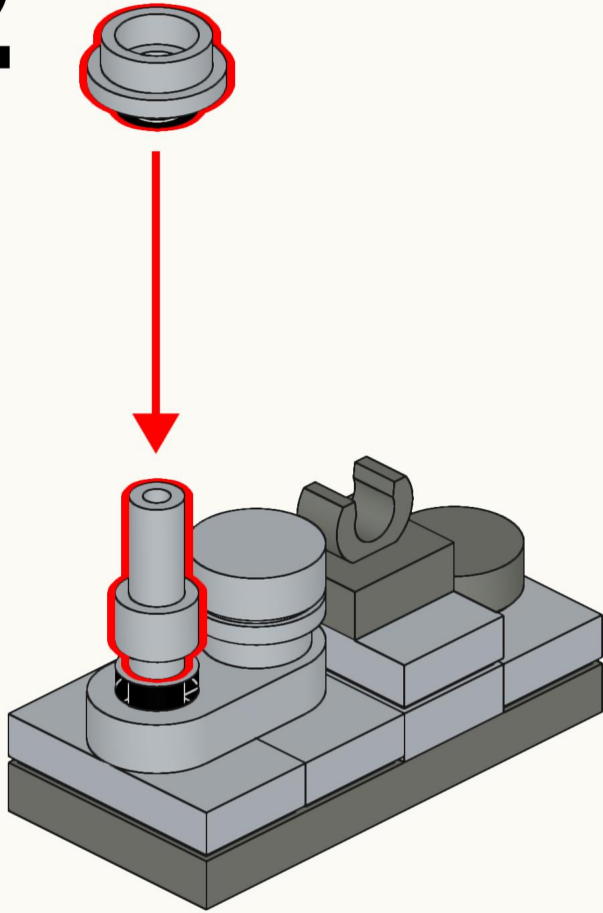

83

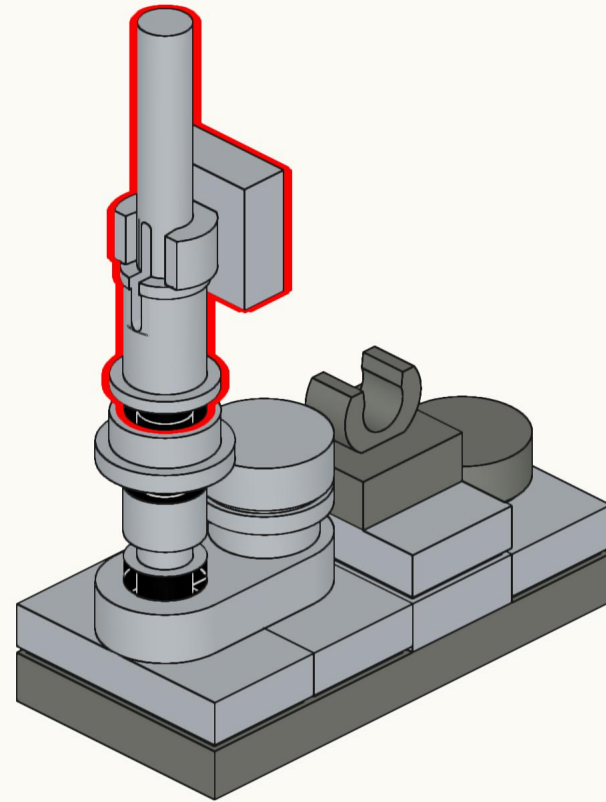

84

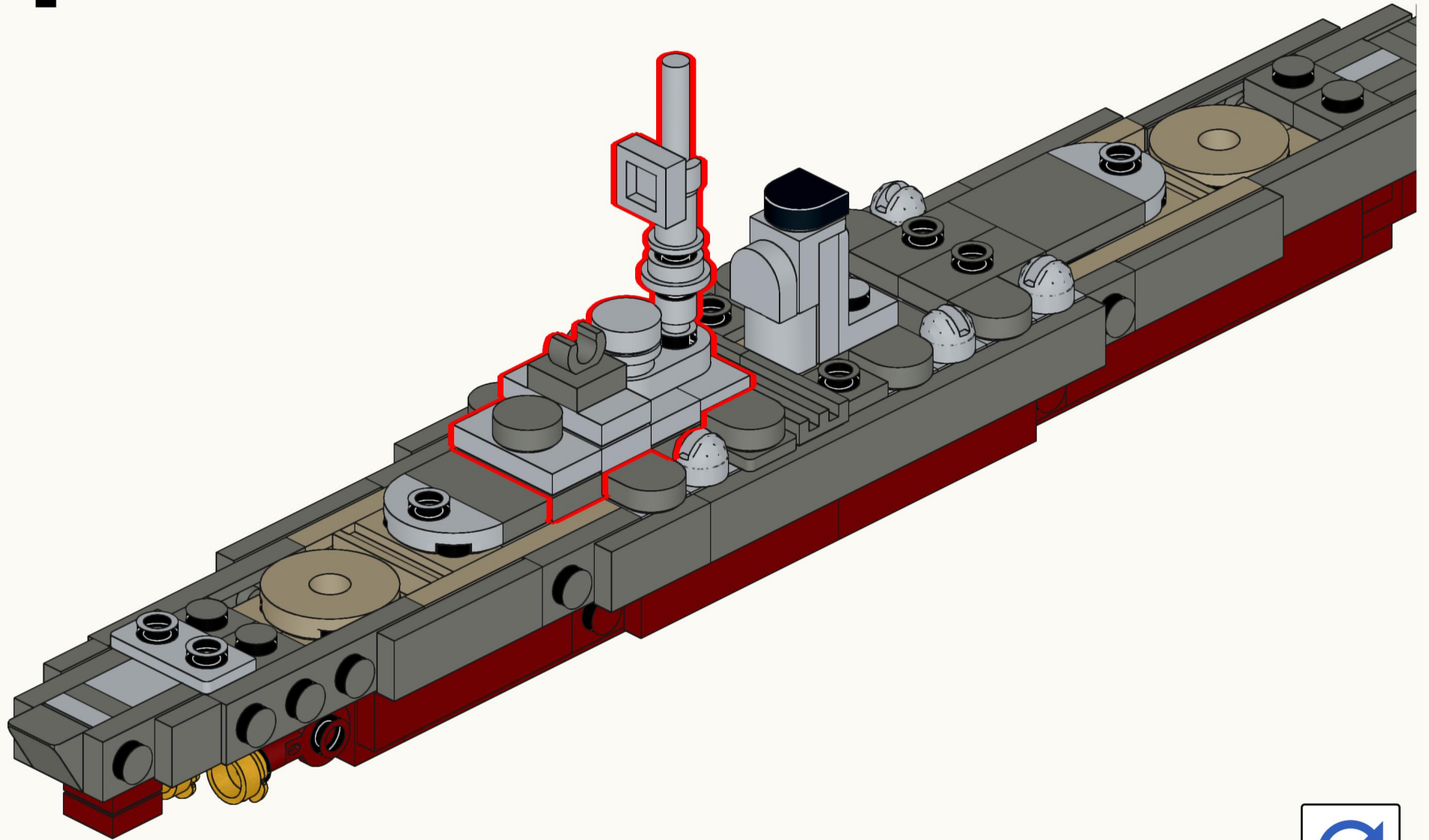

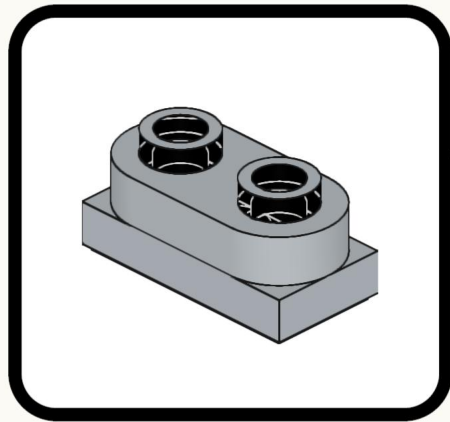
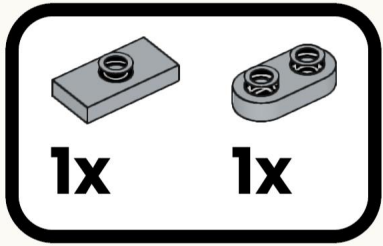

85

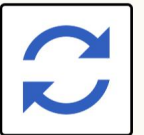
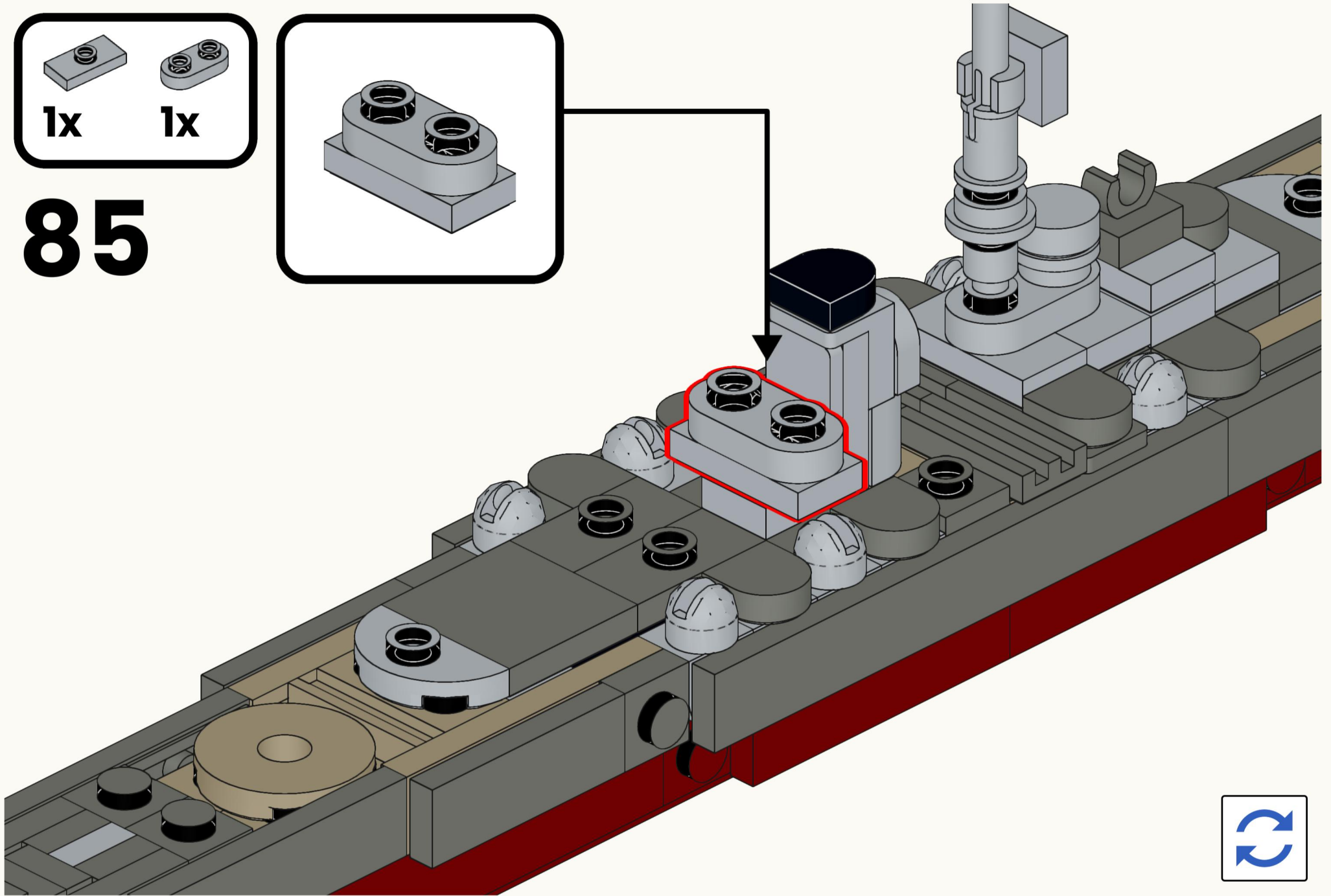

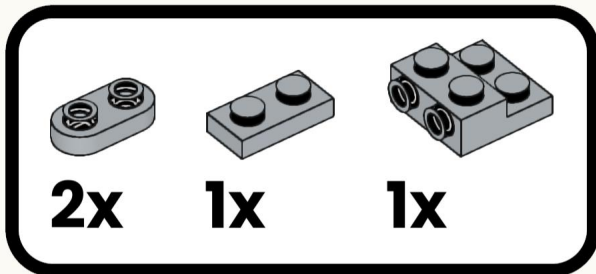
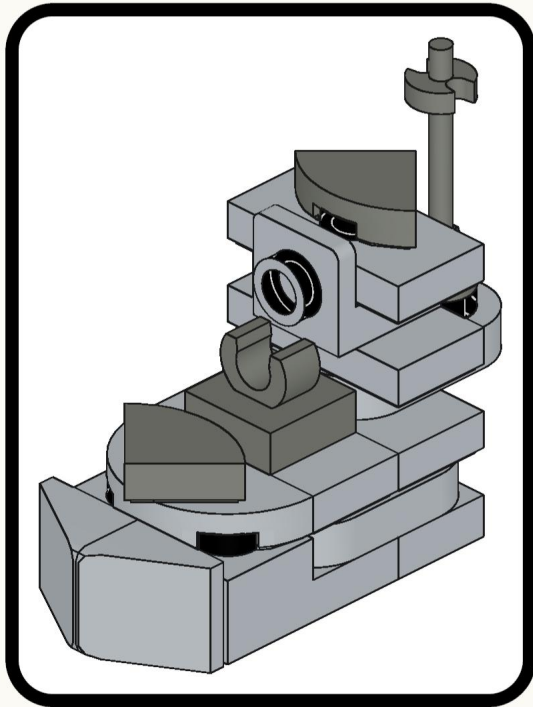

86

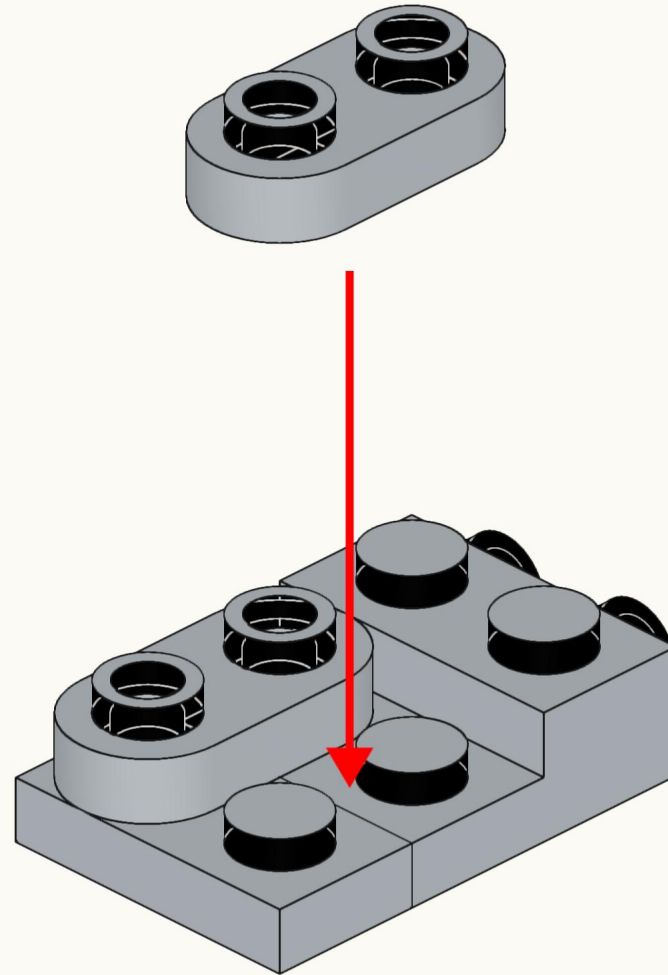

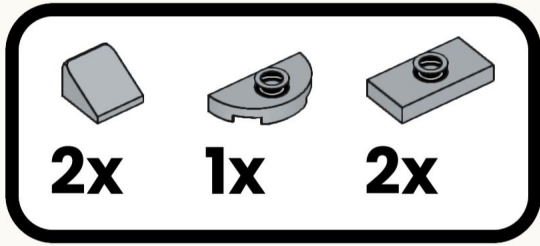

87

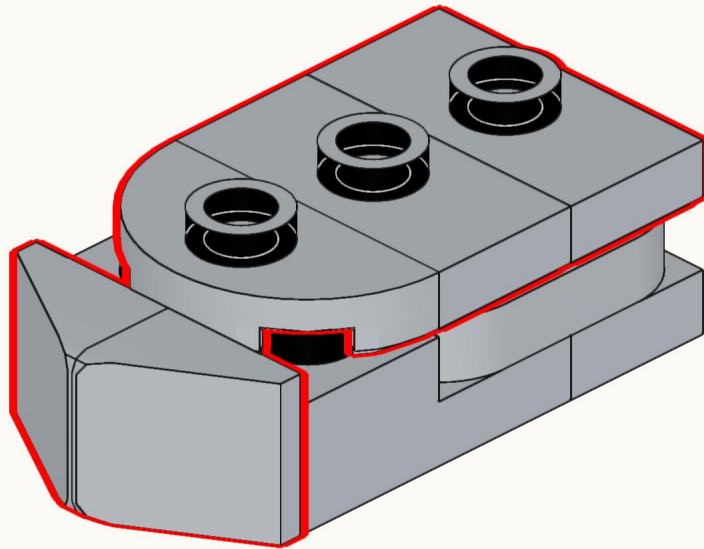

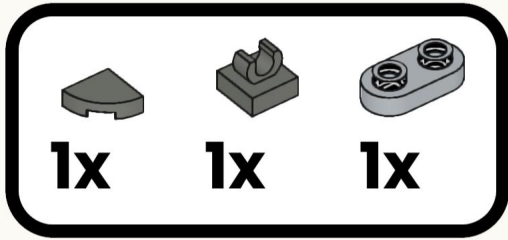

88

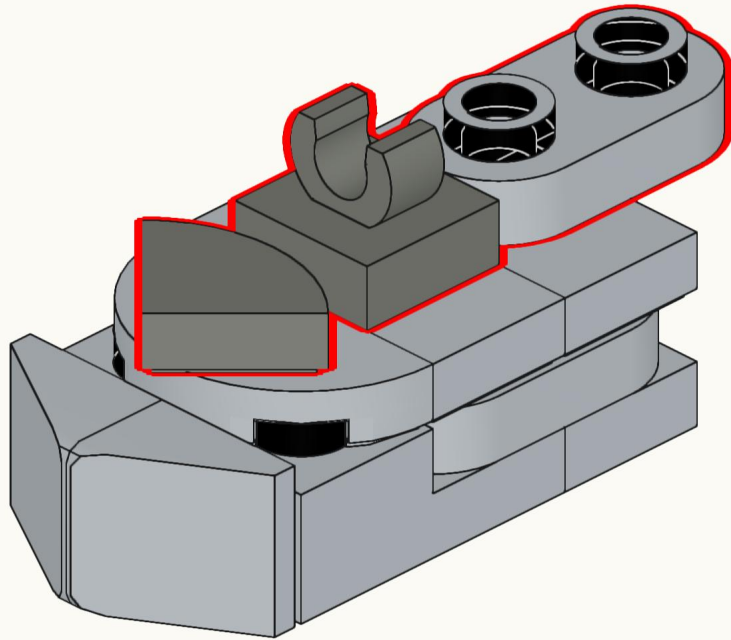

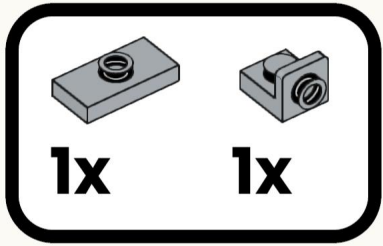

89

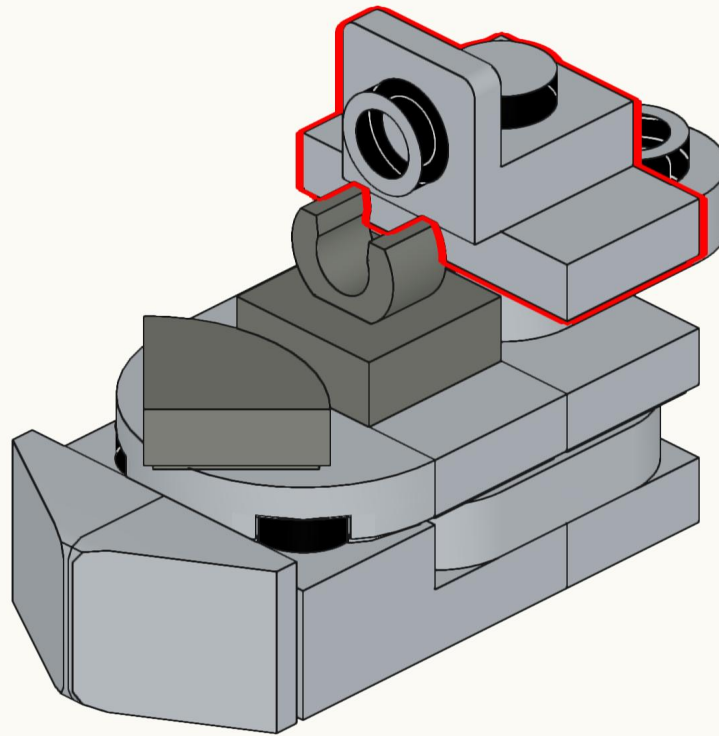

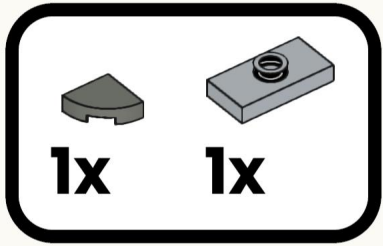

90

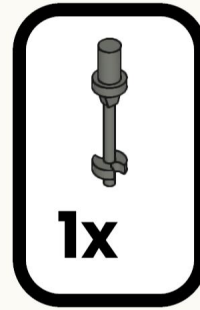
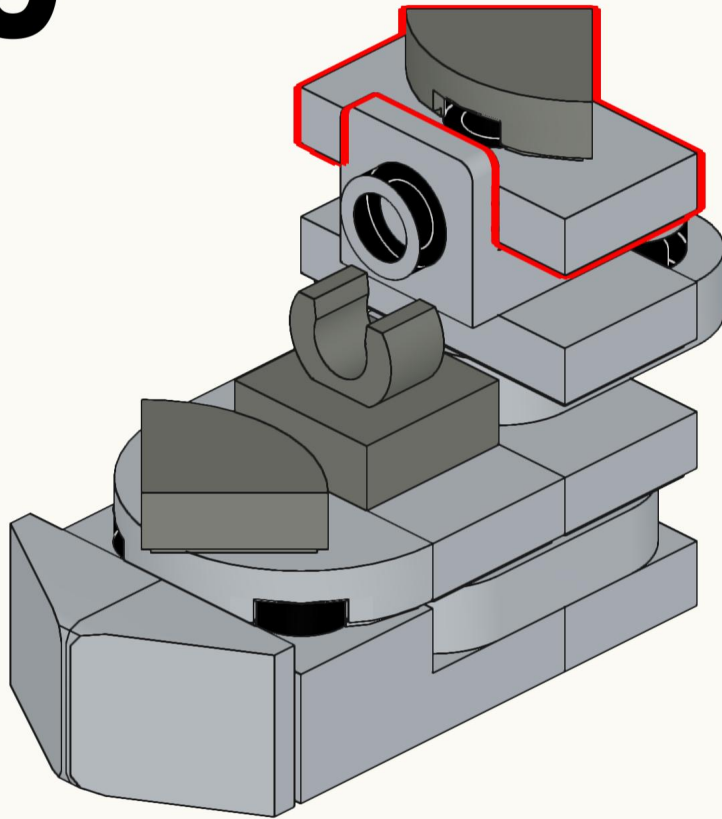

91

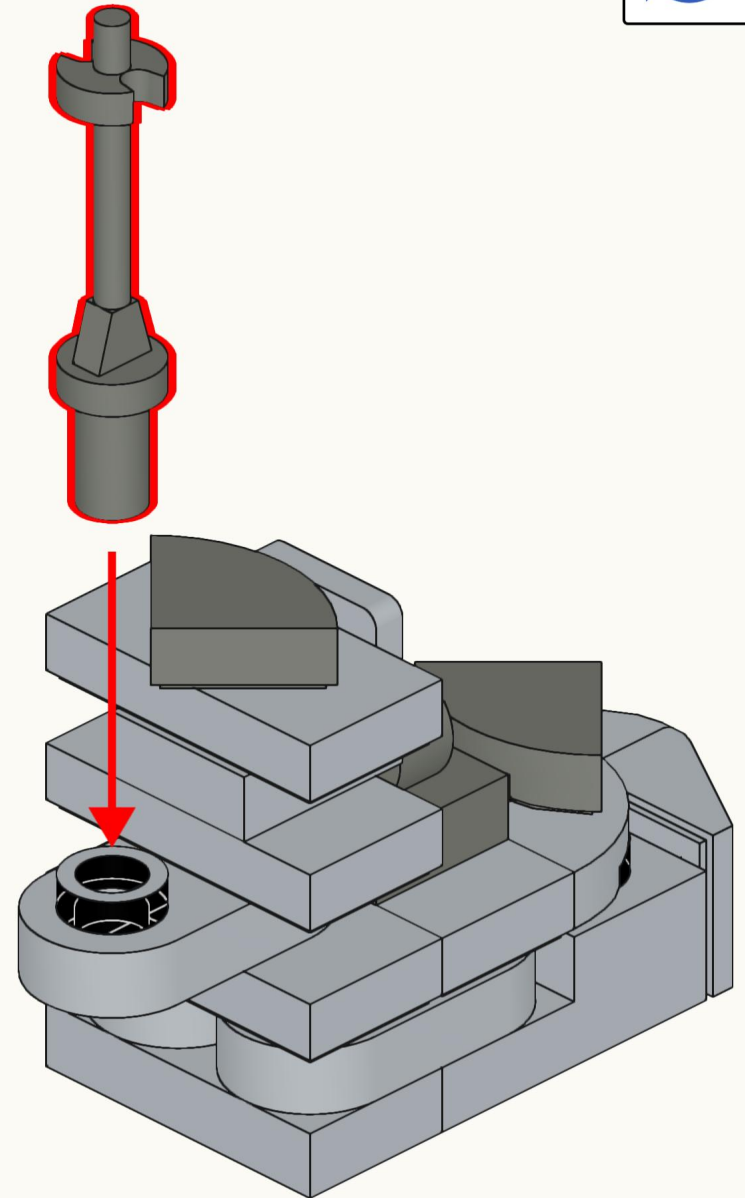

92

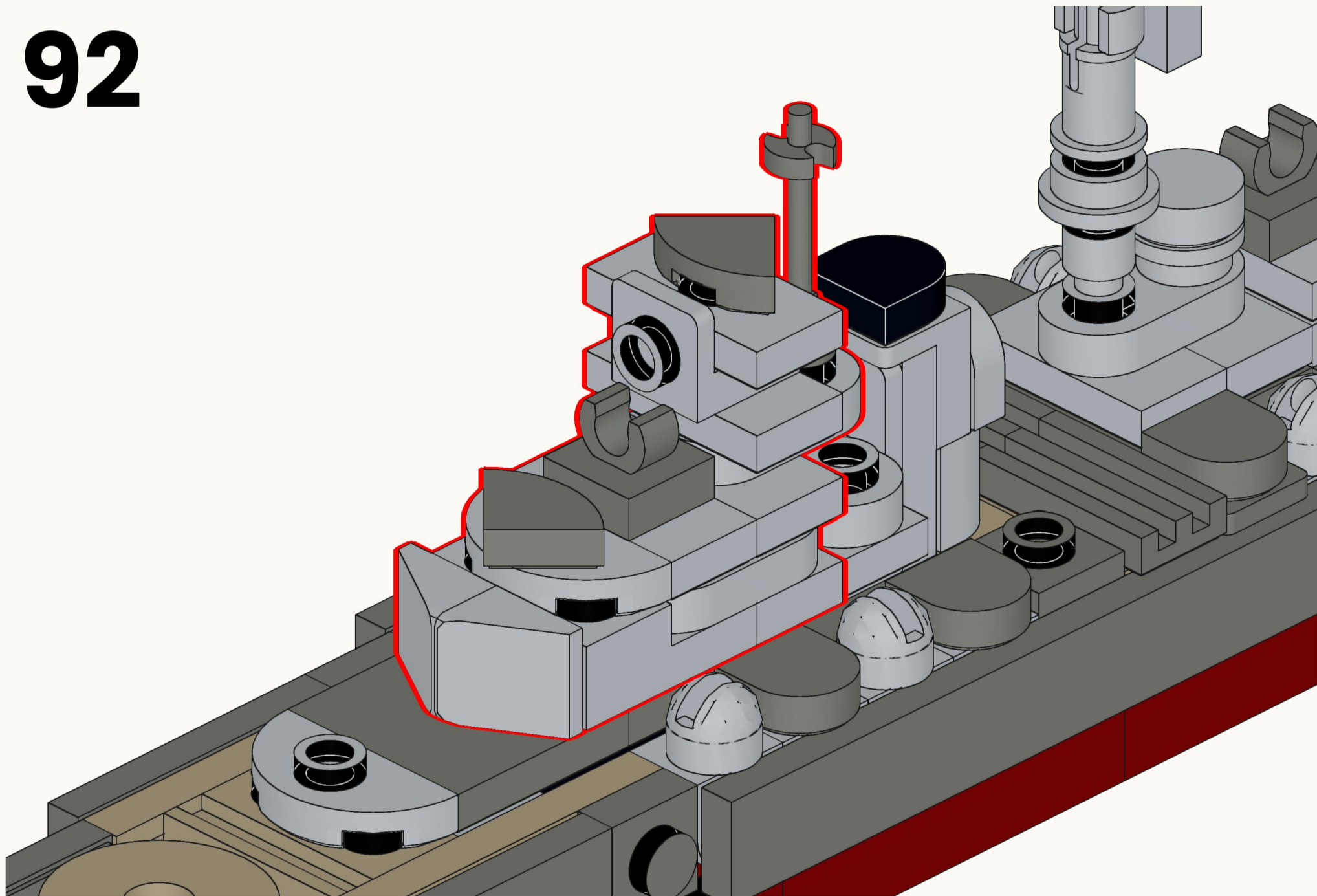

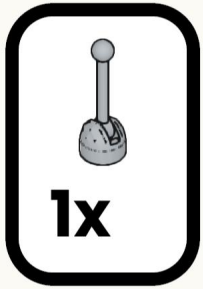

93

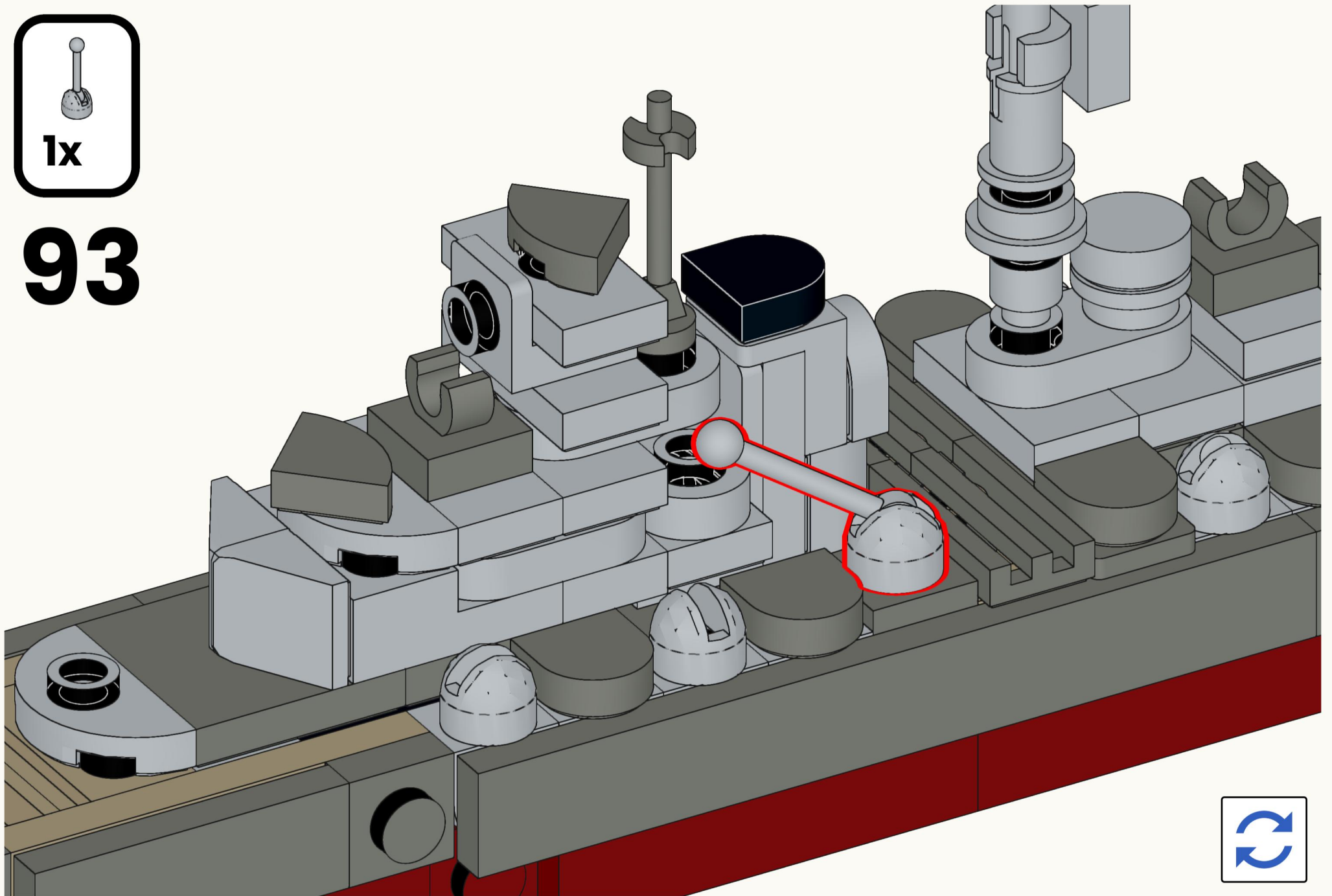

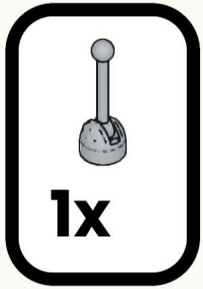

94

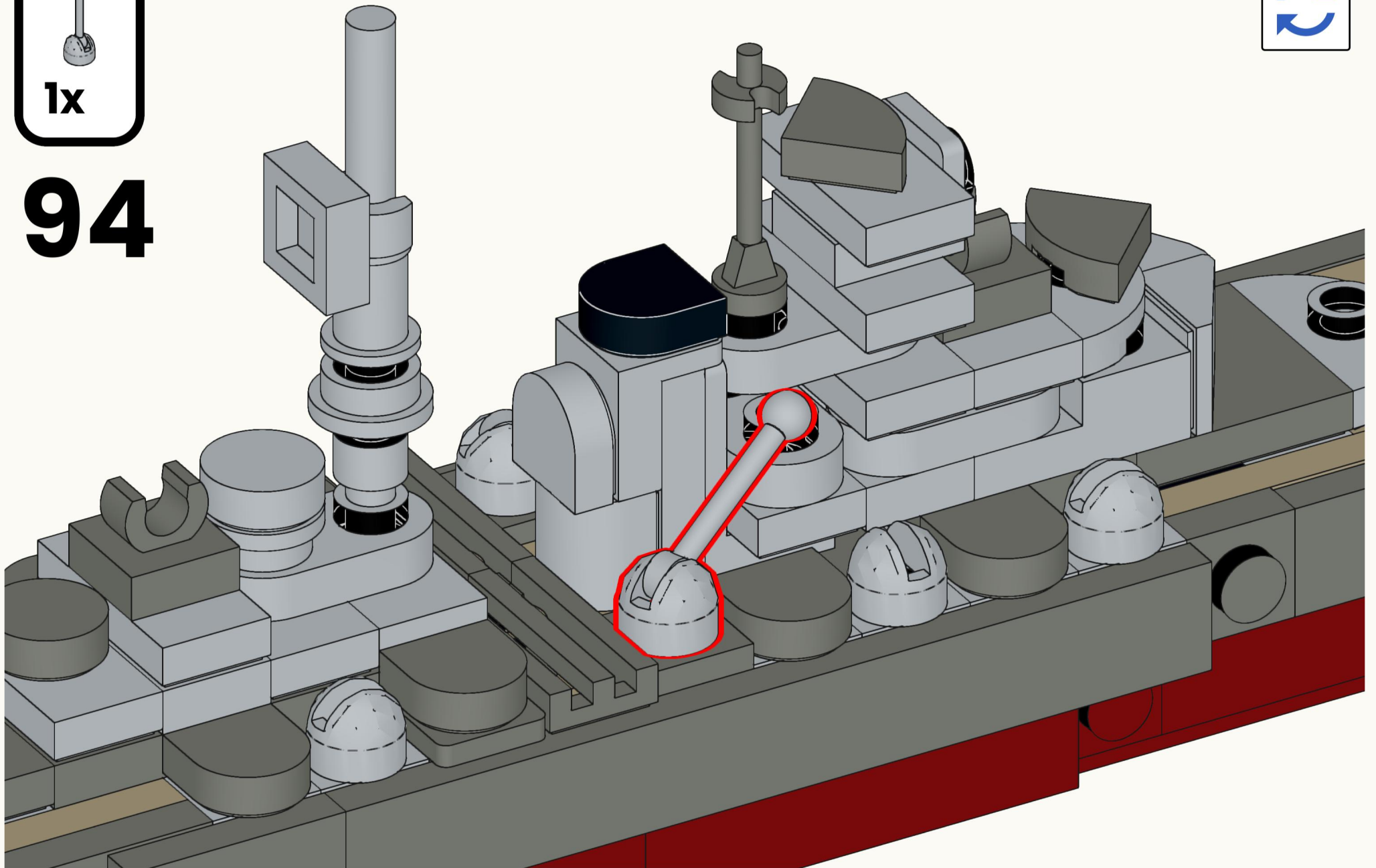

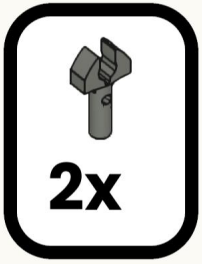
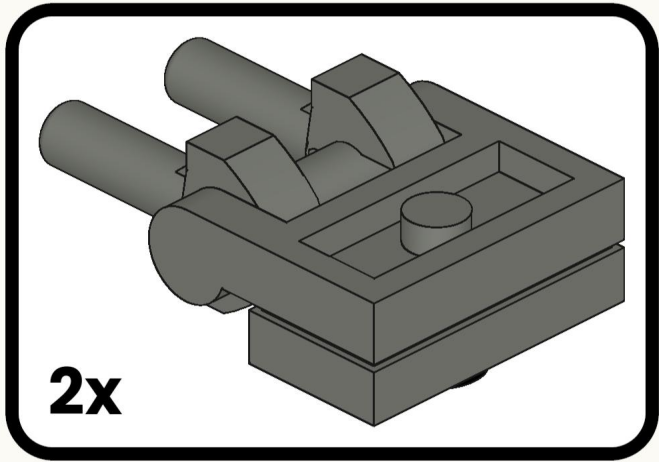

96

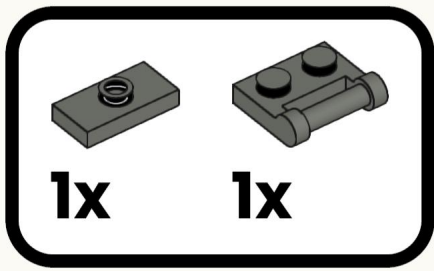

95

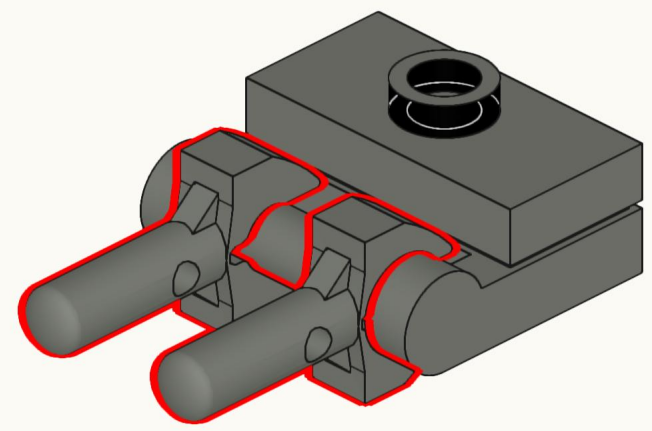
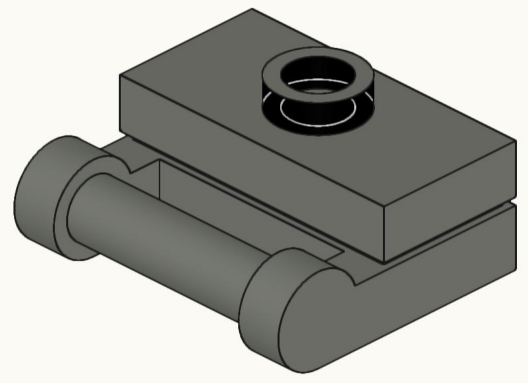

97

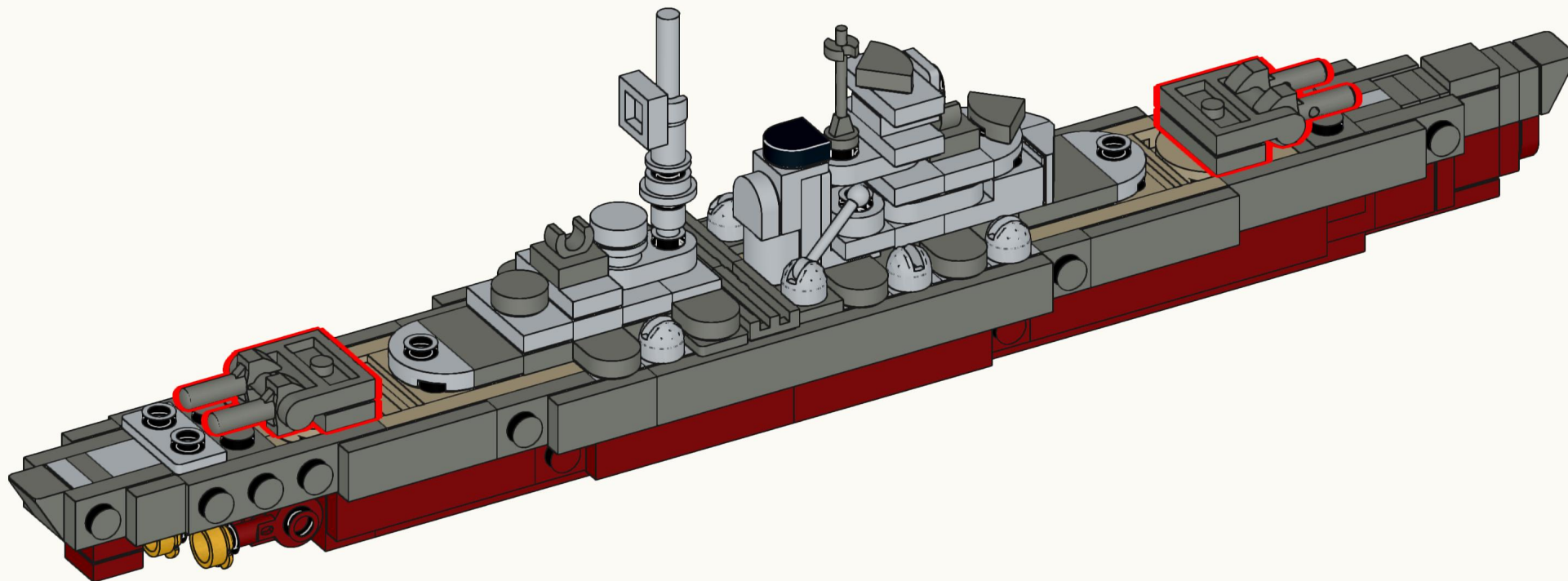

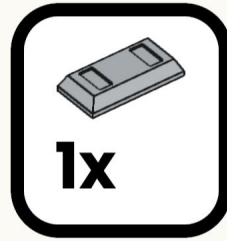
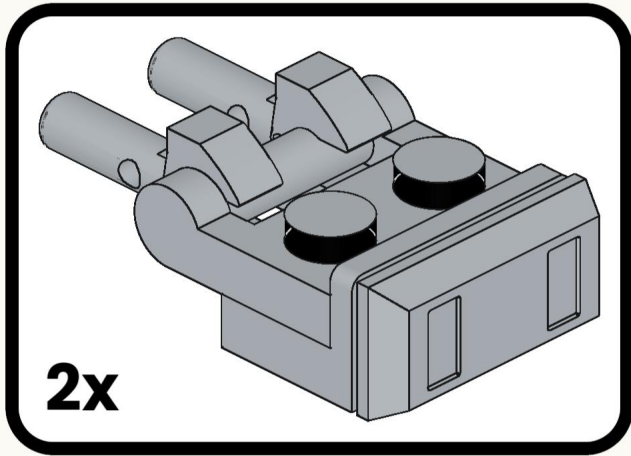

99

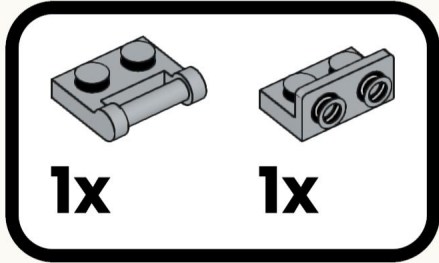

98

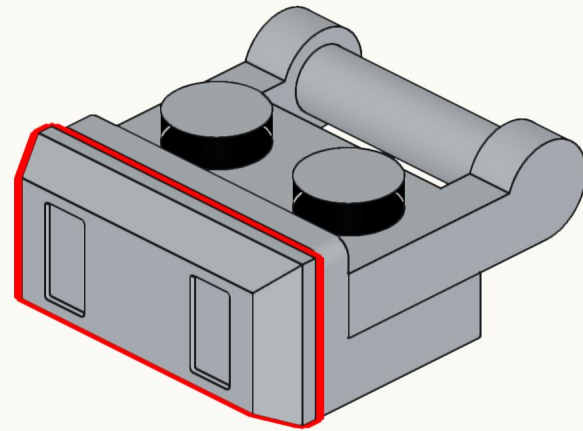
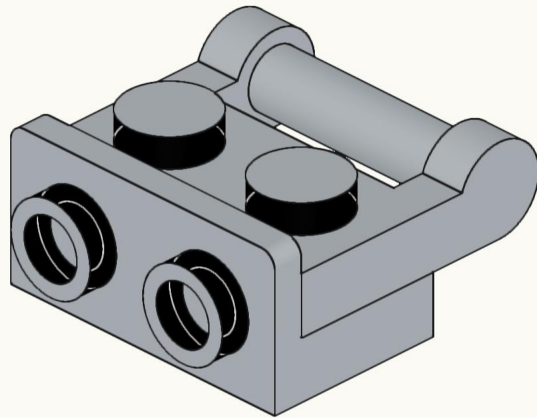

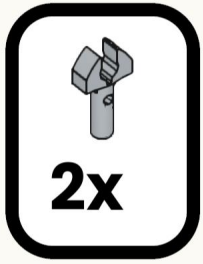

100

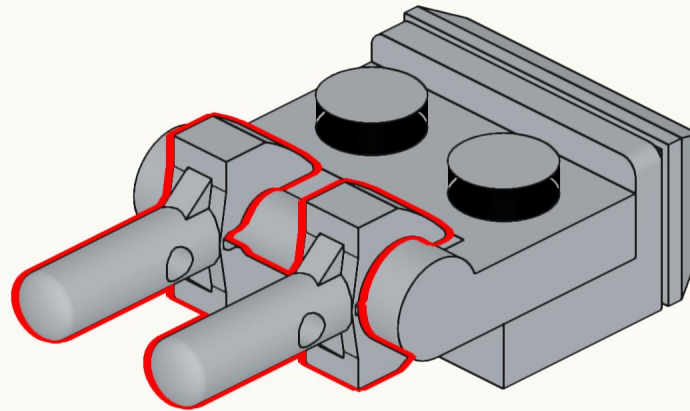

101

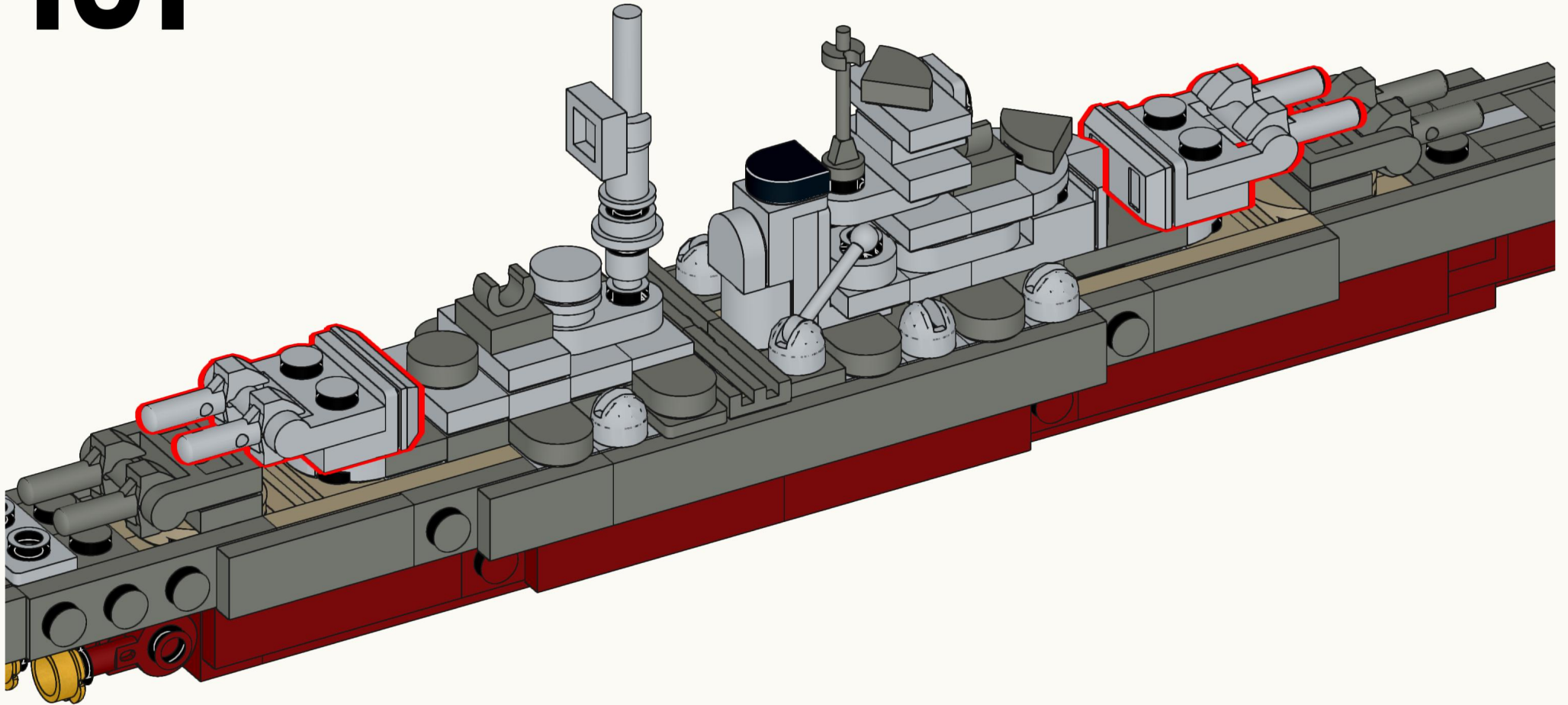

Tirpitz's eight 15-inch guns were fired electrically by the fire control system, but each turret could switch to local independent control. Three fire control stations were positioned fore, on the bridge, and aft, all feeding data to mechanical fire control computers.

102

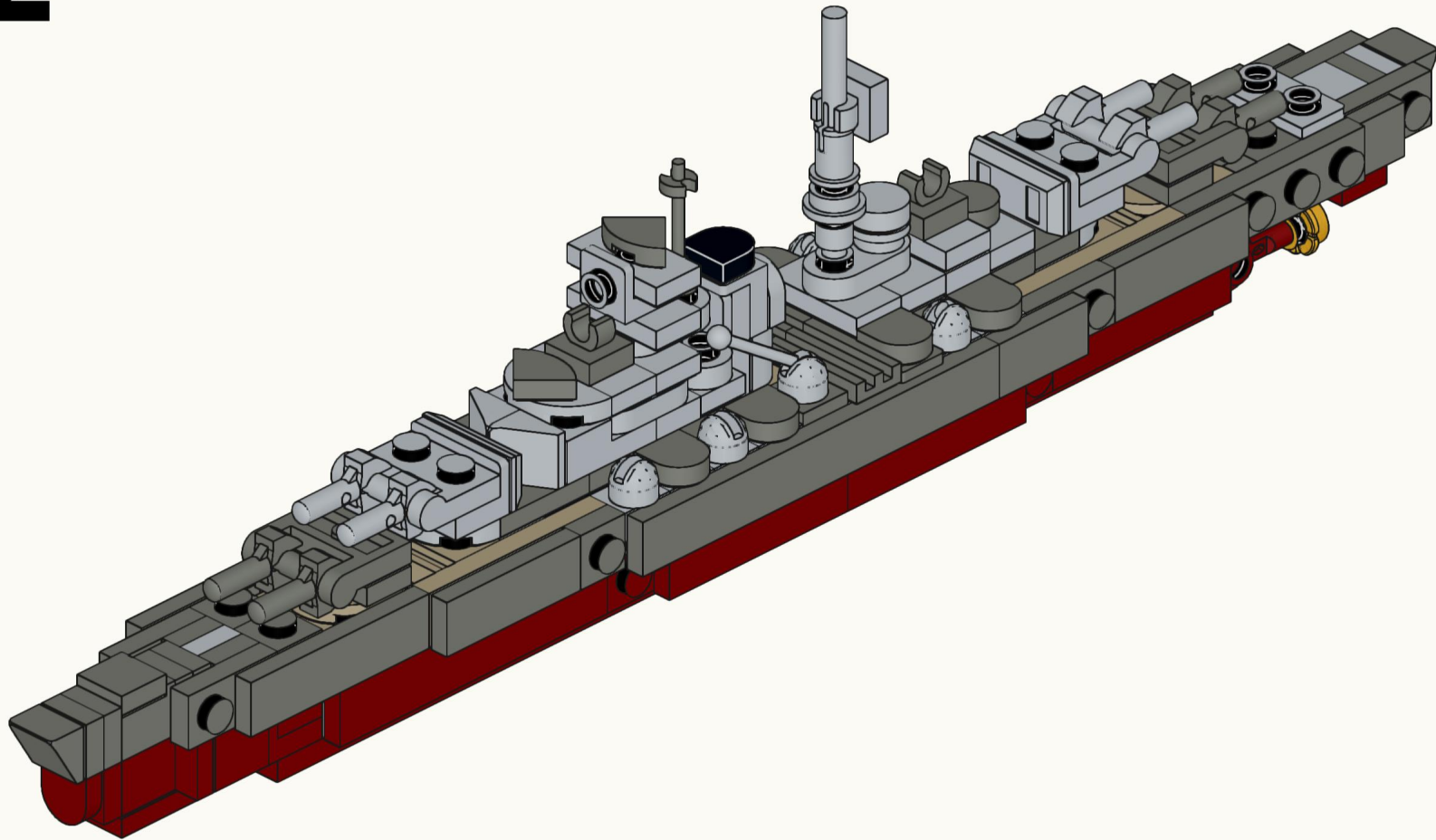

After a series of wartime modifications Tirpitz became 2,000 tonnes heavier than Bismarck, making her the heaviest battleship ever built by a European navy, displacing 52,600 tonnes fully loaded.

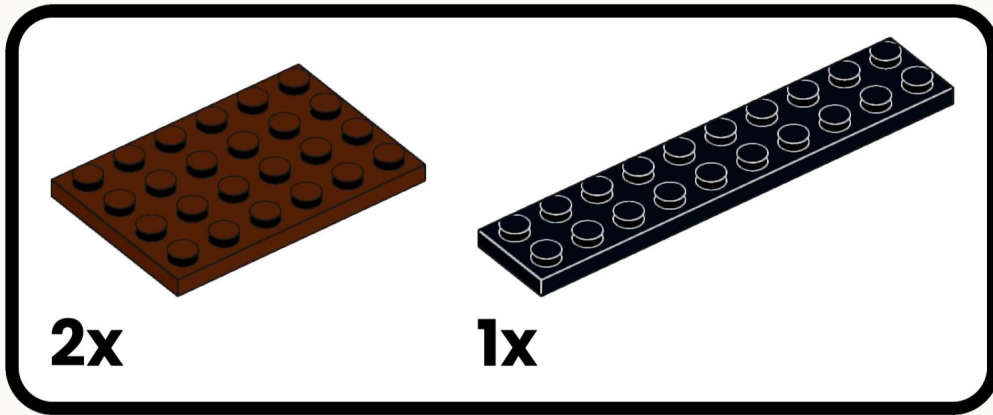
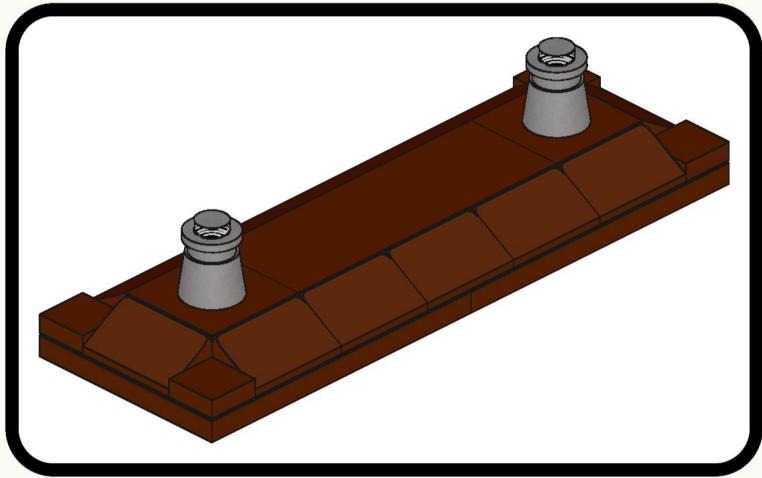

103

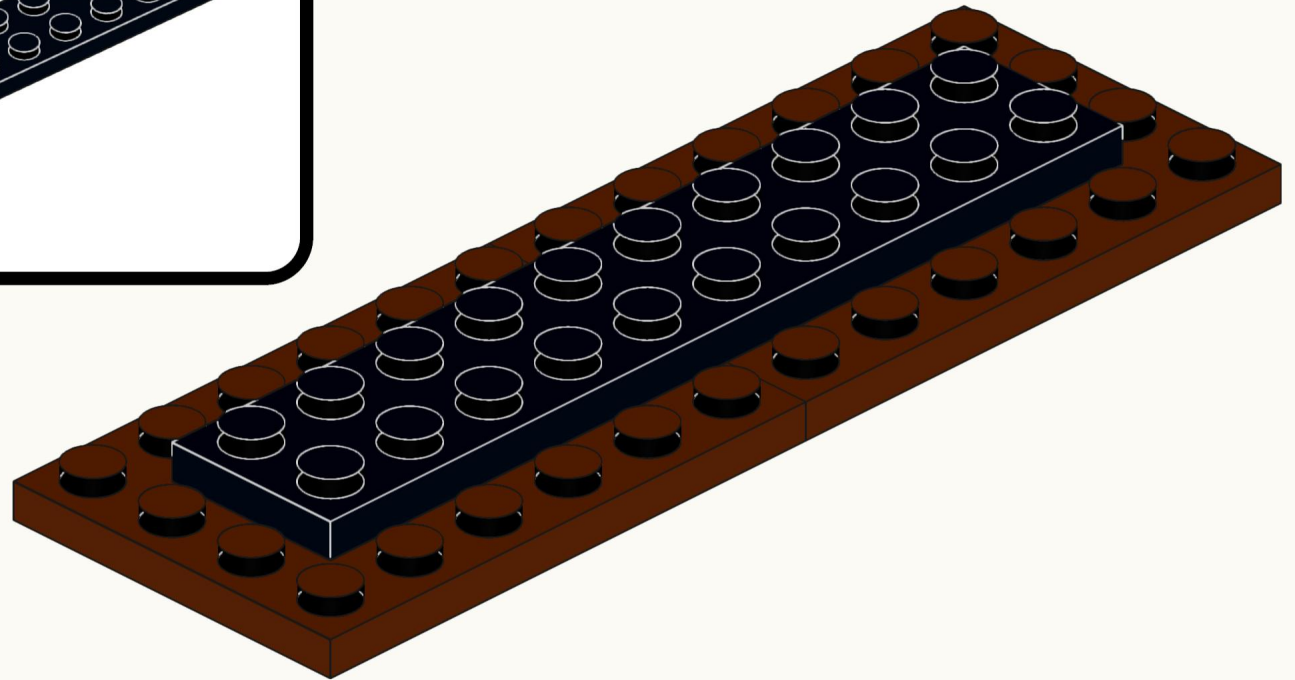



104

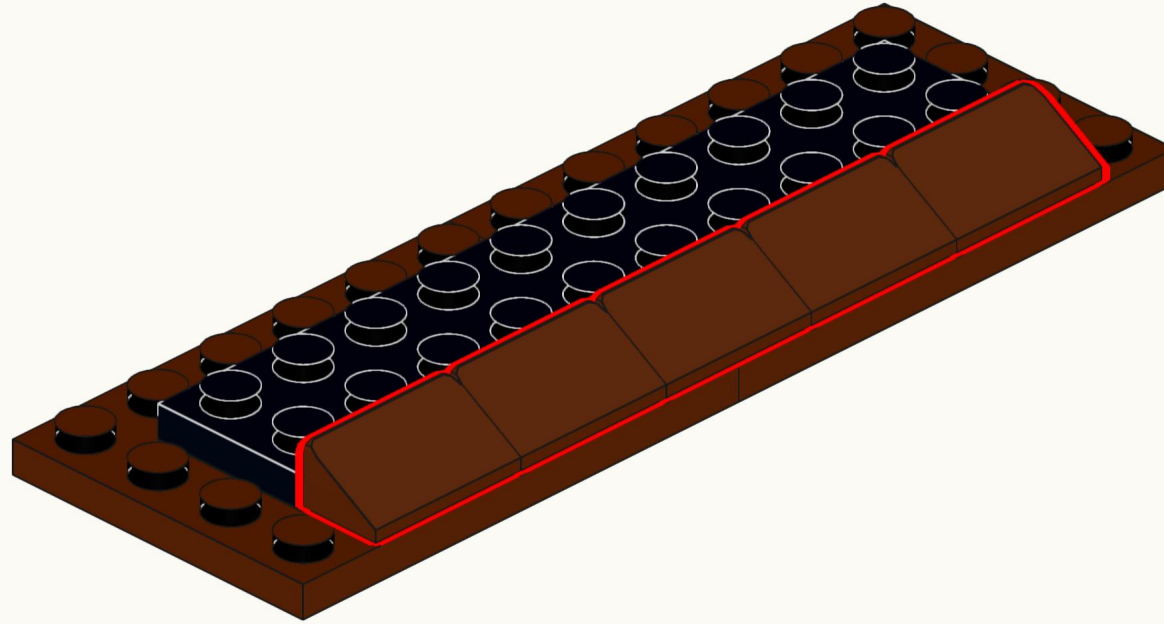

105

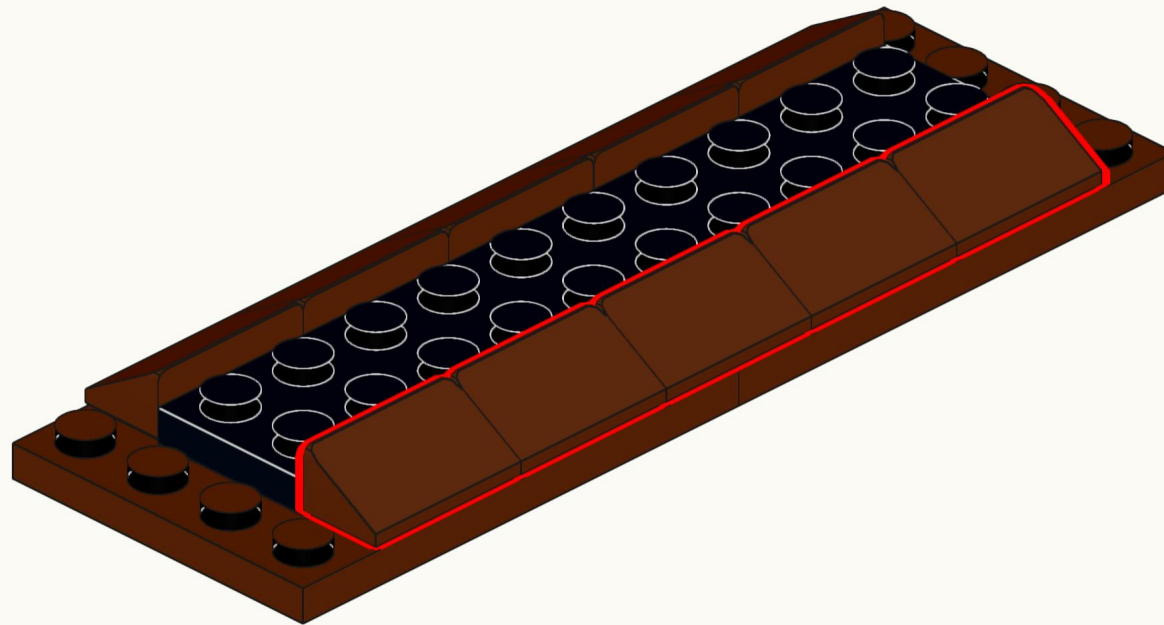

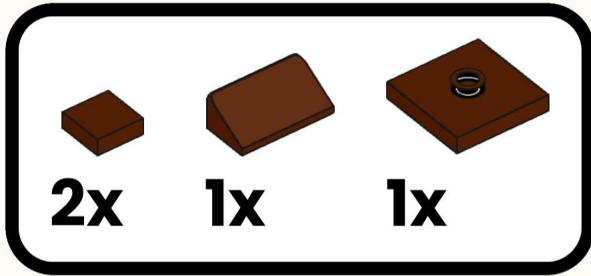

106

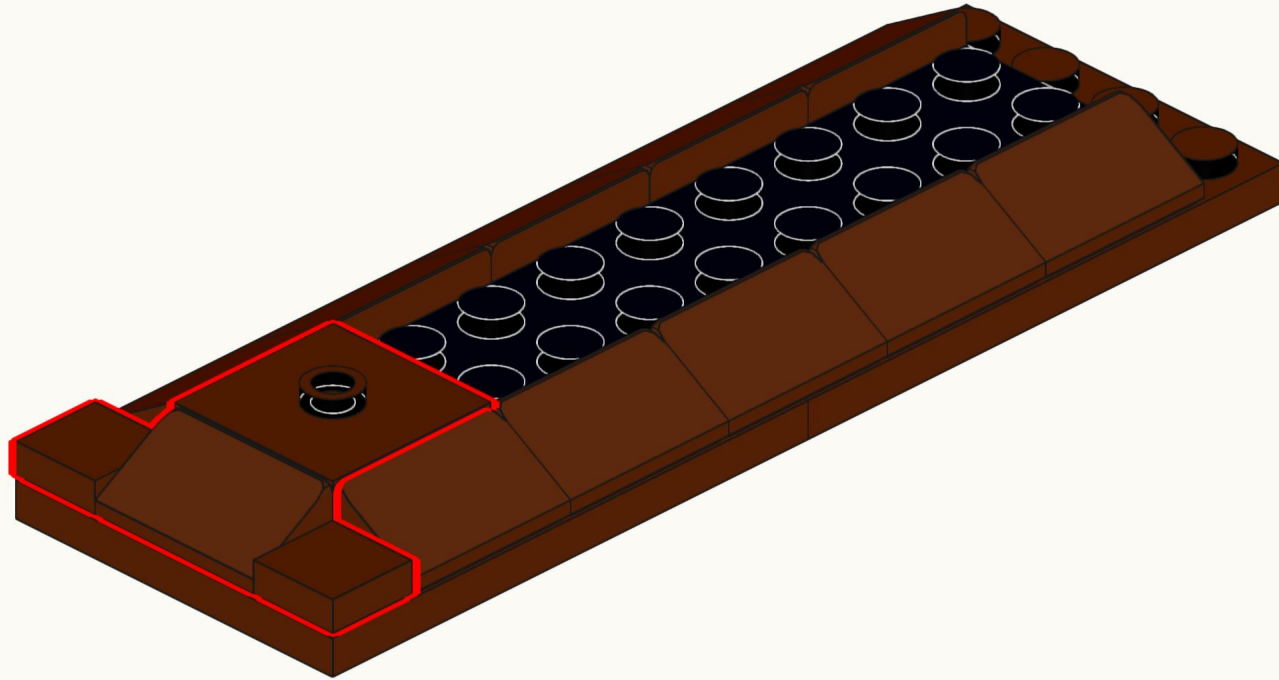

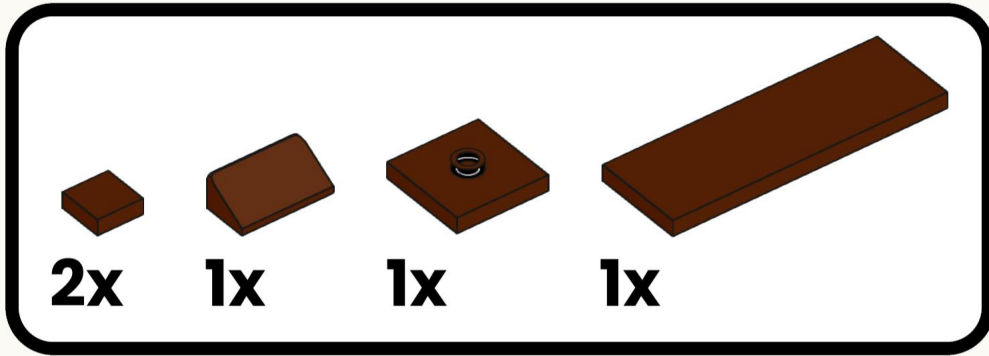

107

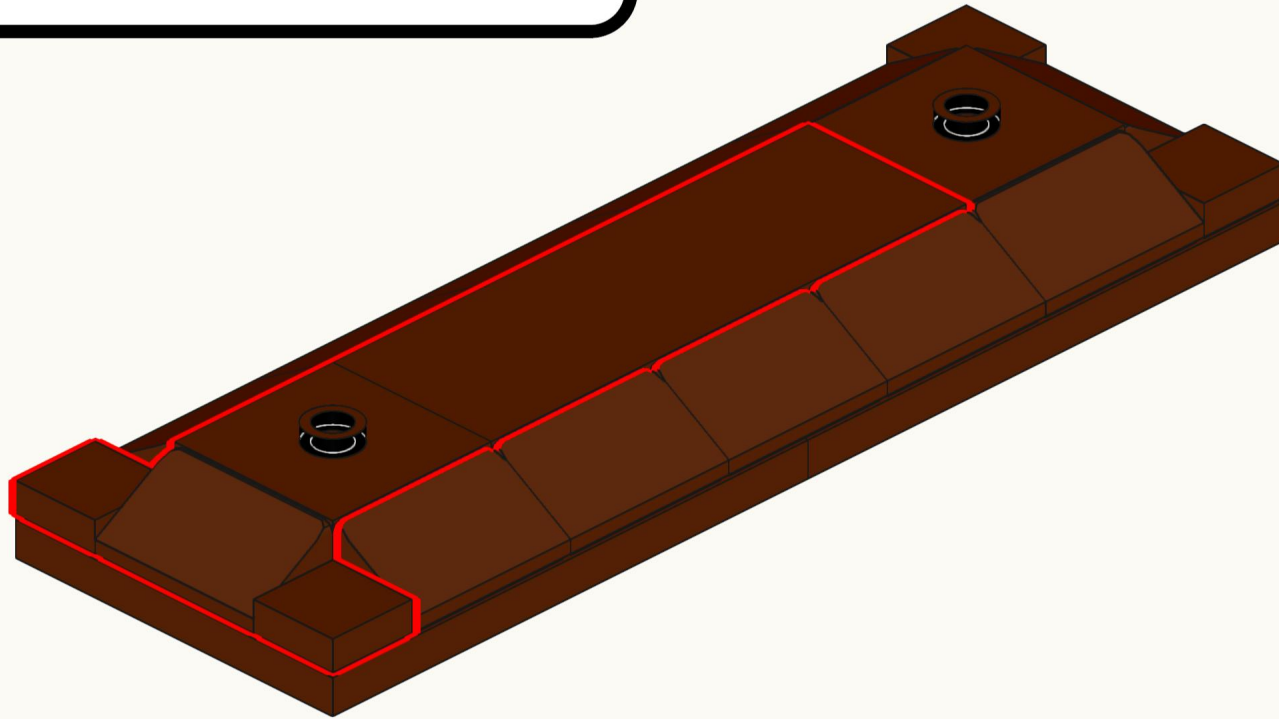

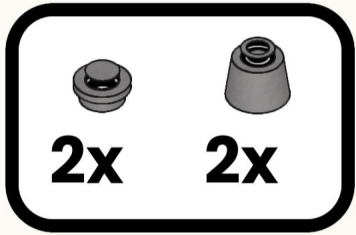

108

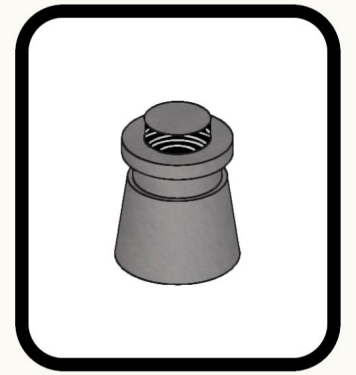
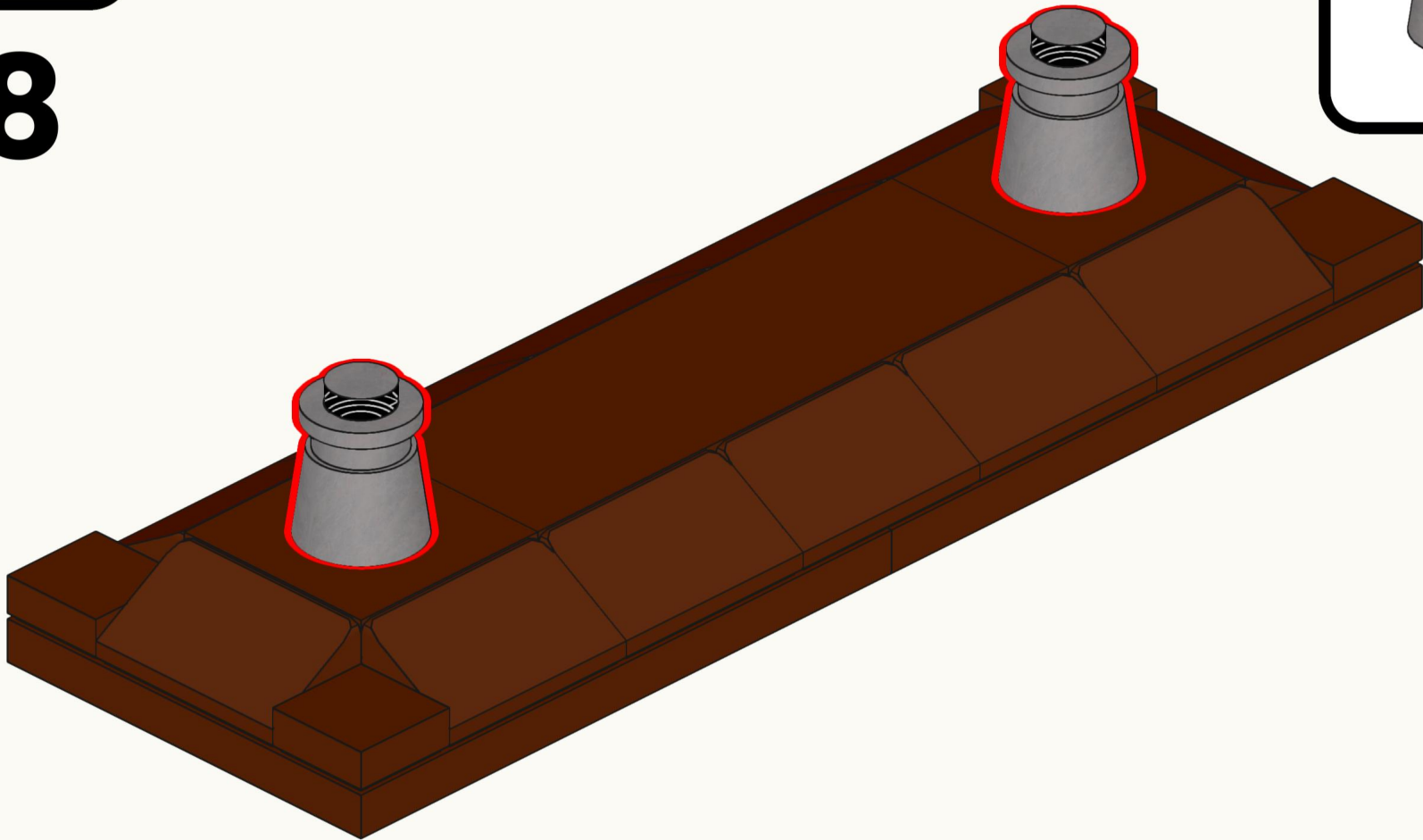

2x



109

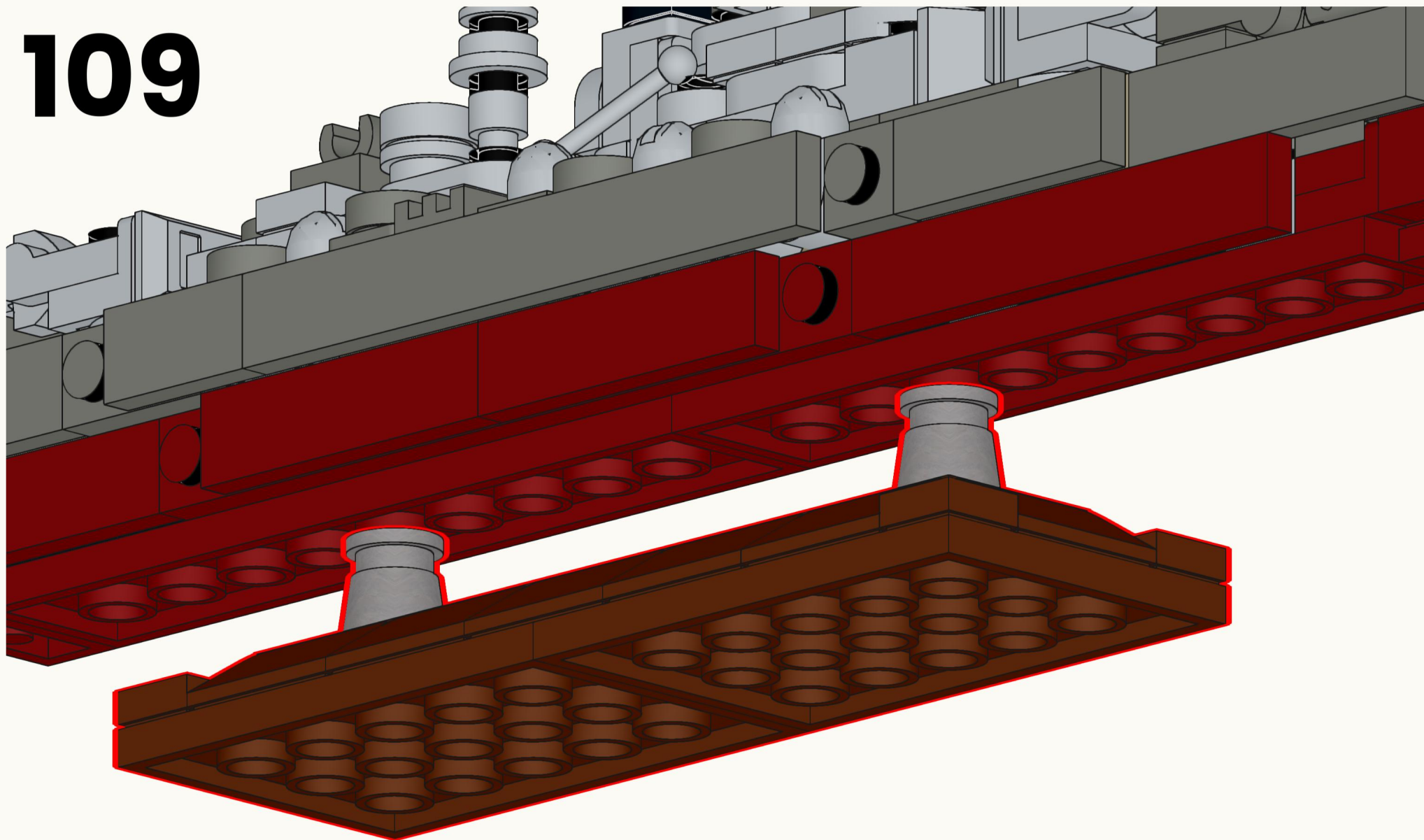

Once finished, you can display the Tirpitz on her display stand or include her in a naval-themed diorama!

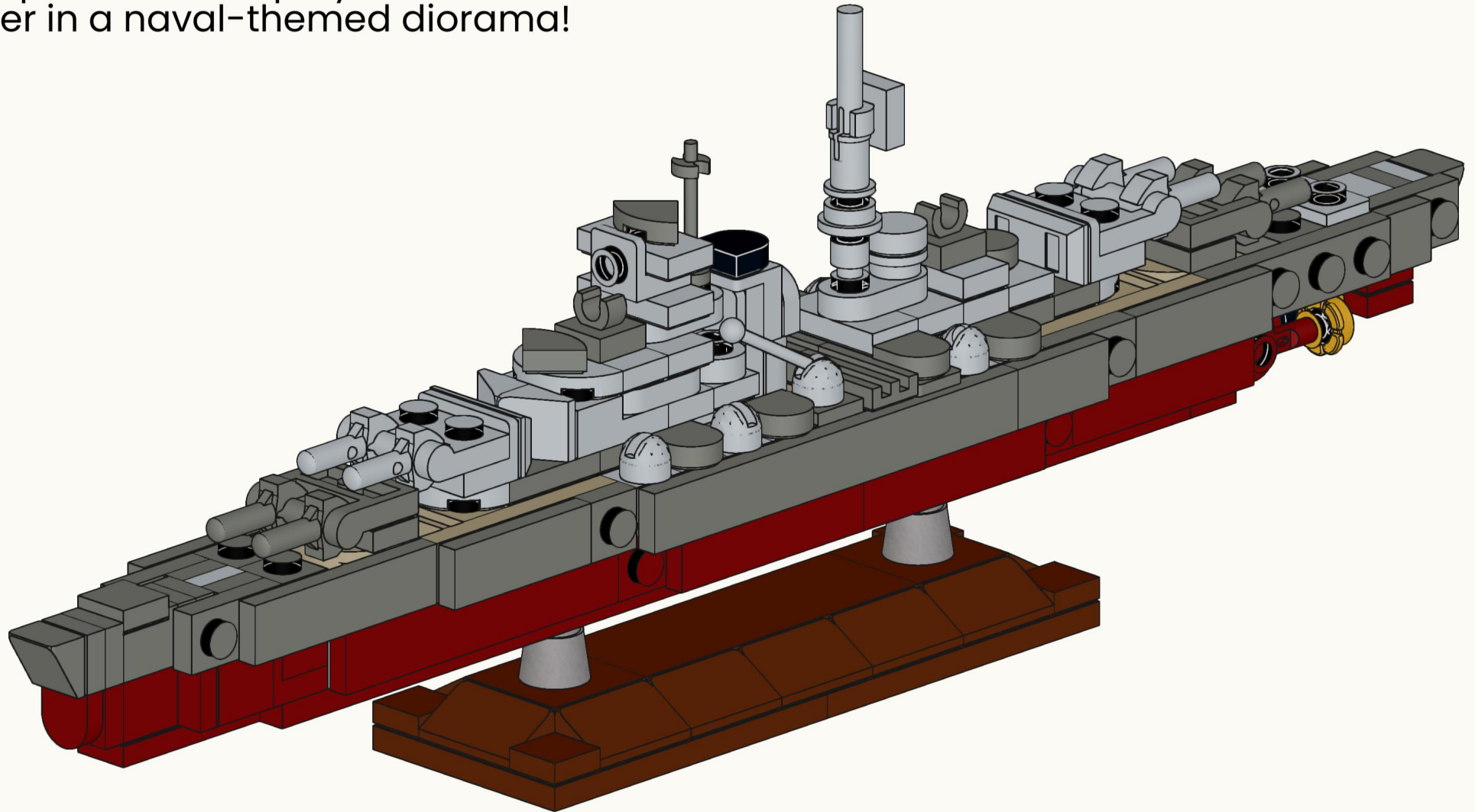

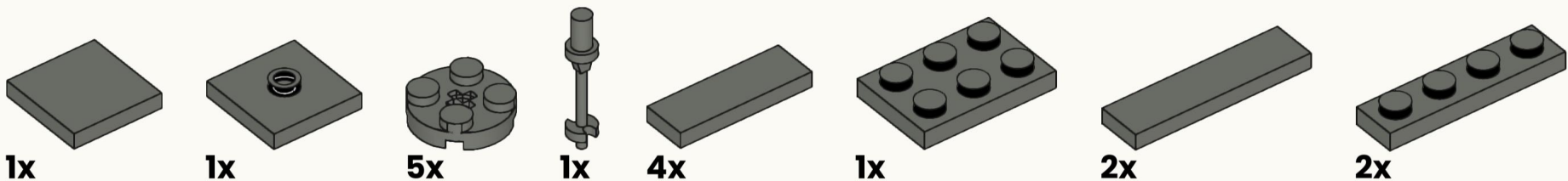
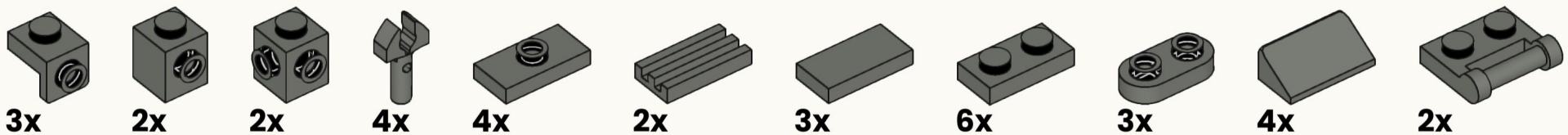
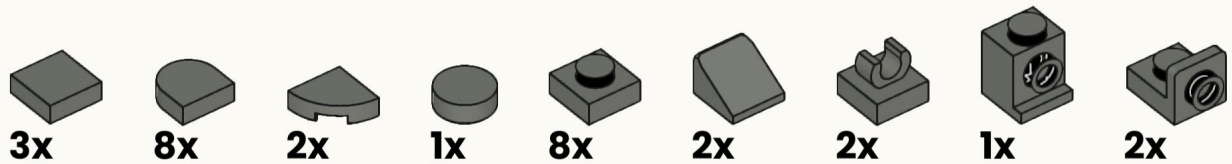
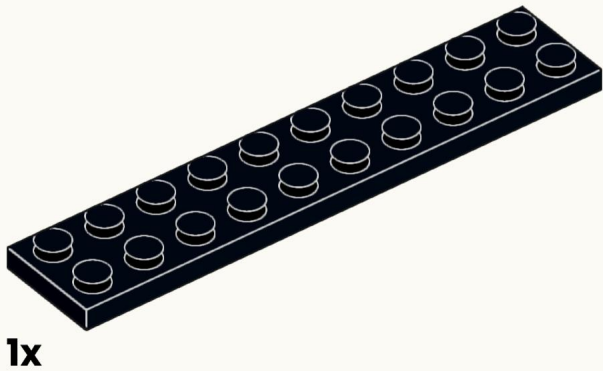
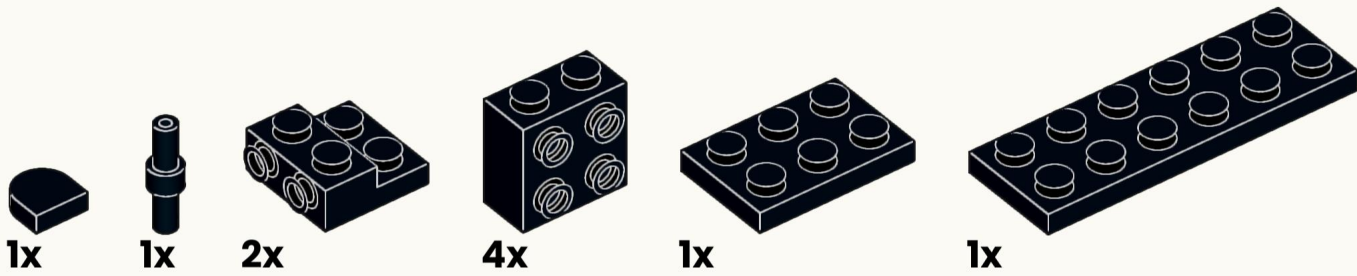

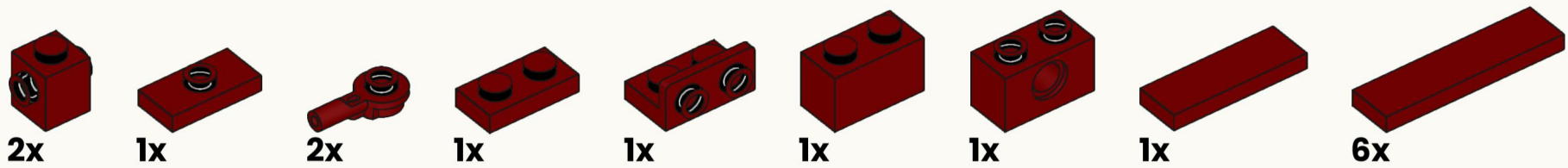
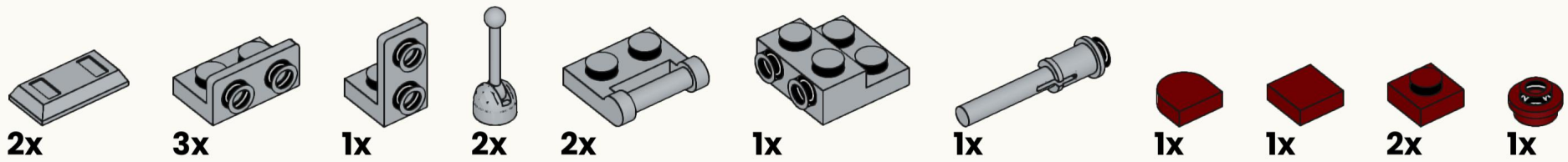
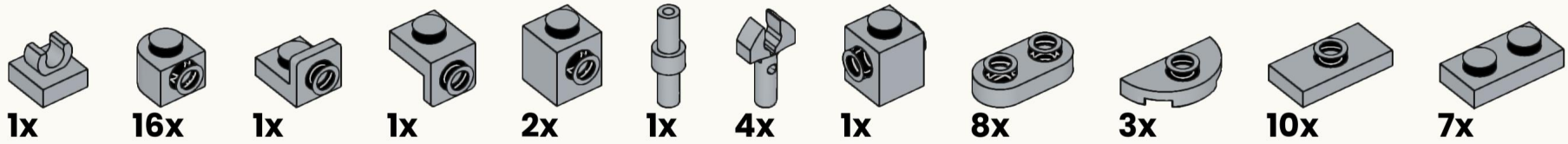
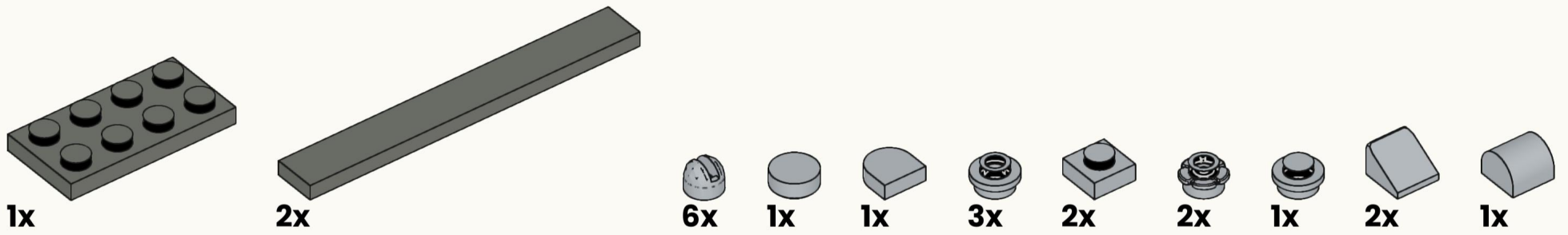

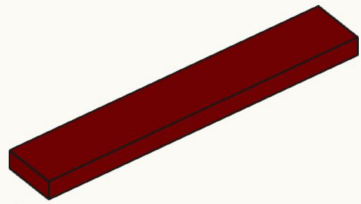

2x

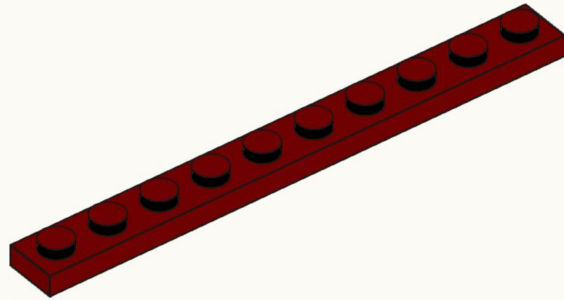

2x

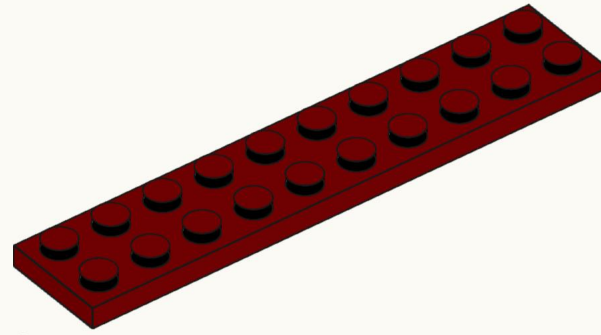

2x

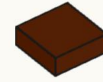

4x



12x

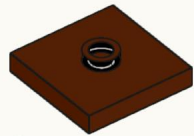

2x

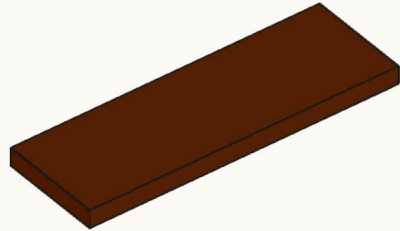

1x

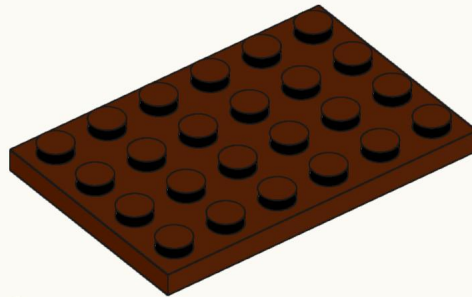

2x

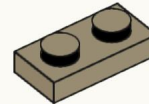

5x



1x

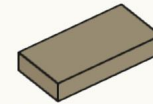

1x

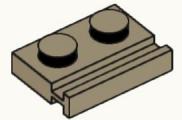

2x

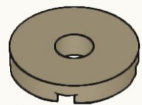

2x

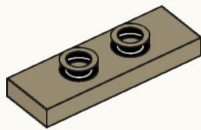

4x

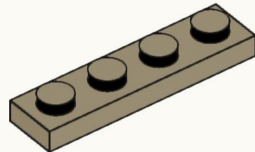

4x

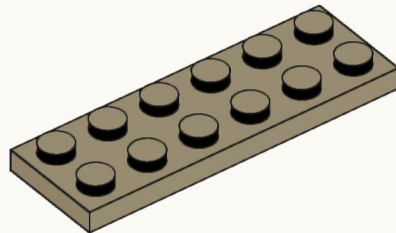

1x

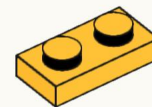

1x



2x



2x



3x

BOBBY BRIX

**DESIGNED BY BOBBY BRIX IN 2026.
ALL RIGHTS RESERVED.**