

# BOBBY BRIX

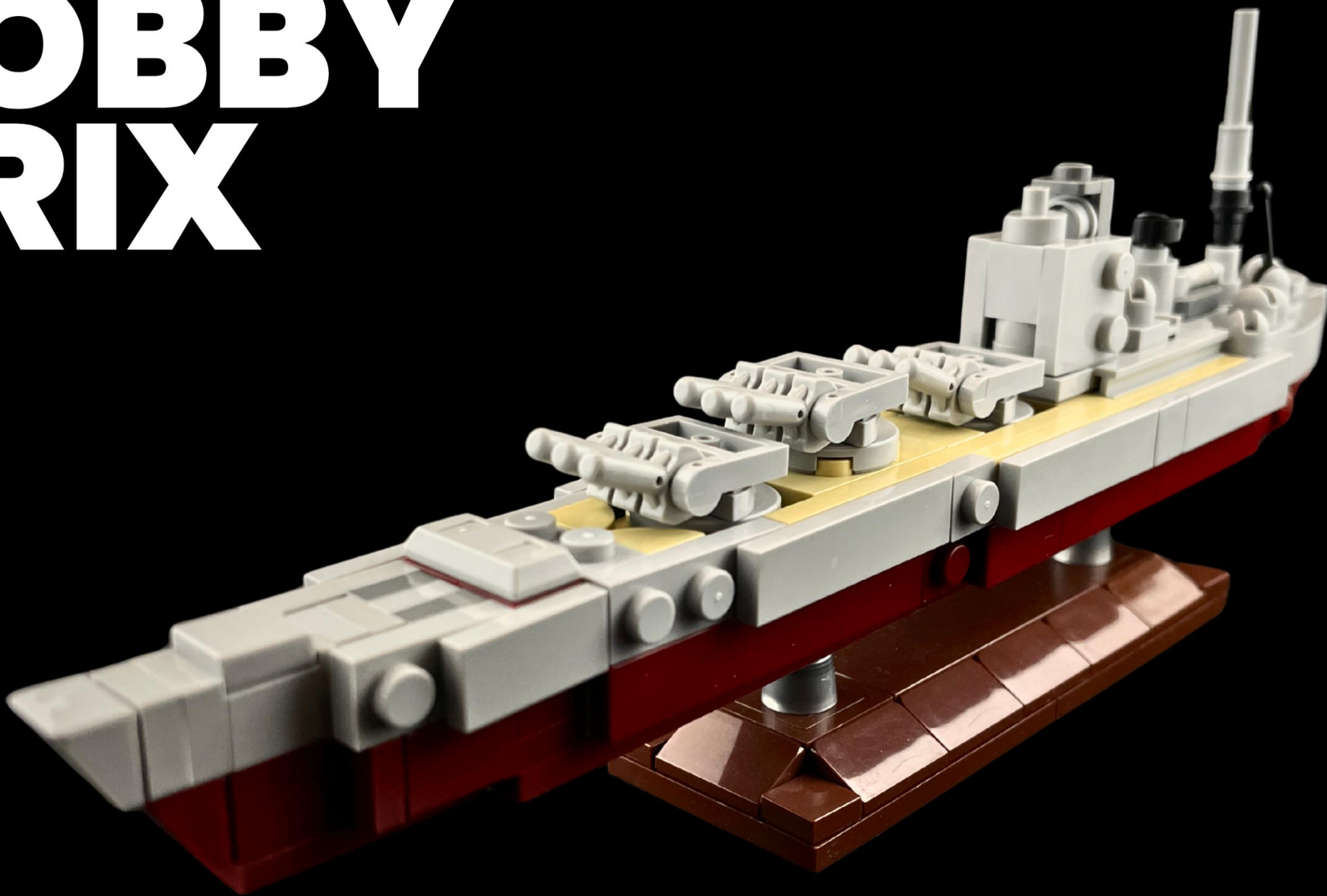

**GB-010 | MOC #0351**

**HMS Nelson** (pennant number 28) was the lead ship of the **Nelson-class battleships** and the first British capital ship built under the **Washington Naval Treaty** limits. Commissioned in 1927, she spent her peacetime career with the Atlantic and Home Fleets, often as flagship.

At the start of World War II, she hunted German commerce raiders and escorted **Atlantic convoys** but was badly damaged by a mine in late 1939. Repaired and redeployed, Nelson escorted **Malta convoys** in 1941 before being torpedoed.

She later supported major Allied landings, including **Operation Torch** in North Africa, the invasions of Sicily and Italy, and provided naval gunfire during the Normandy landings in June 1944 until hitting another mine.

After repairs and a brief stint with the **Eastern Fleet** in 1945, she returned home, became a training ship, and was scrapped in 1949 after being used for bomb tests.

# HMS NELSON BATTLESHIP MOC + DISPLAY STAND

<b>MODEL #0351B</b>	<b>UNITS</b>	<b>WIDTH</b>	<b>LENGTH</b>	<b>HEIGHT</b>
<b>1:1000 SCALE</b>	<b>STUDS</b>	<b>4.4</b>	<b>27.4</b>	<b>10.8</b>
<b>208 PARTS + SPARES</b>	<b>INCHES</b>	<b>1.4</b>	<b>8.6</b>	<b>3.4</b>
<b>DESIGNED IN 2026</b>	<b>CENTIMETERS</b>	<b>3.5</b>	<b>21.9</b>	<b>8.6</b>

This My Own Creation (MOC) is an original design and product by BOBBY BRIX.

- Usage: For personal and non-commercial use only. Redistribution or reselling without permission is prohibited.
- Attribution: You may reuse, remix, or adapt this product with proper credit to the creator and original design.
- Ownership: All designs, images, and materials are owned by BOBBY BRIX & The Bobby Brix Channel unless stated otherwise.

For inquiries about public display, commercial use, or resale, please contact BOBBY BRIX.

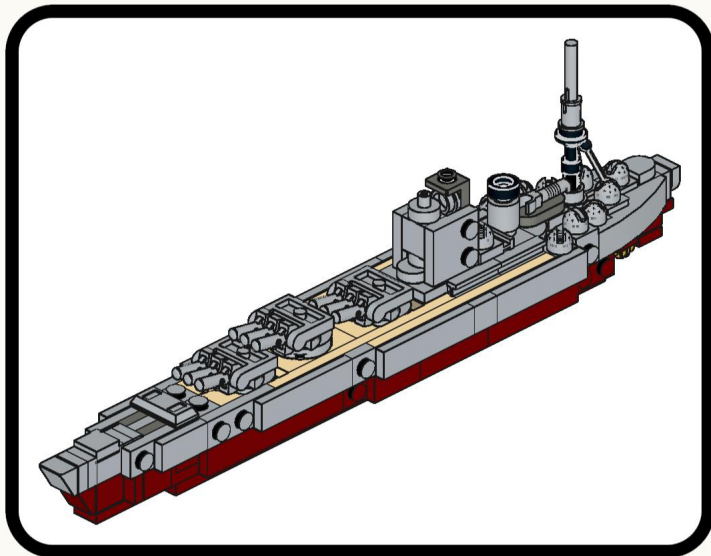
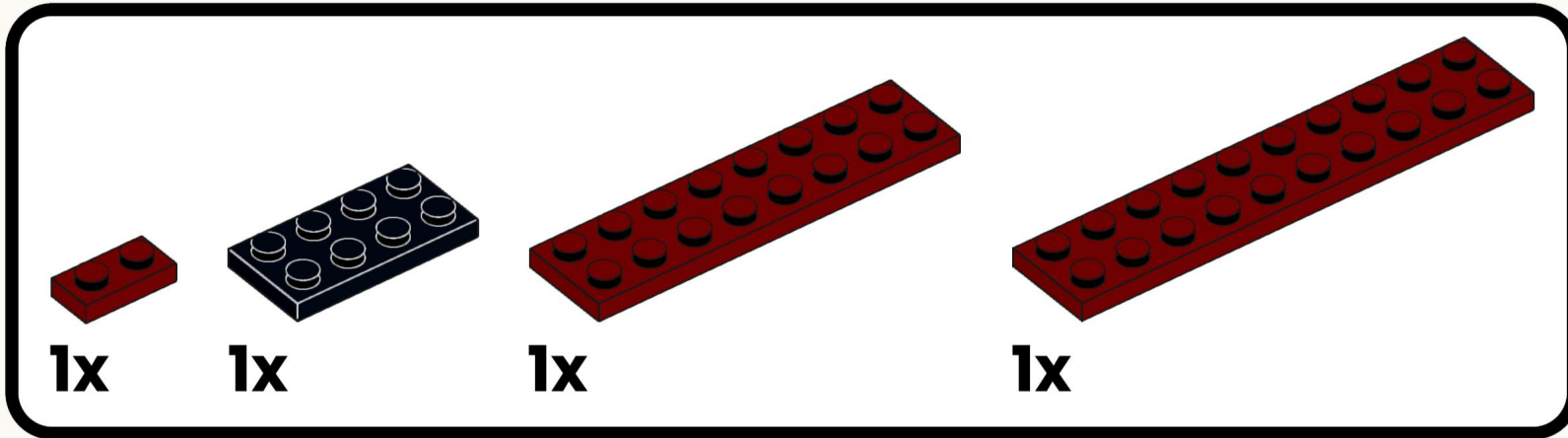

1

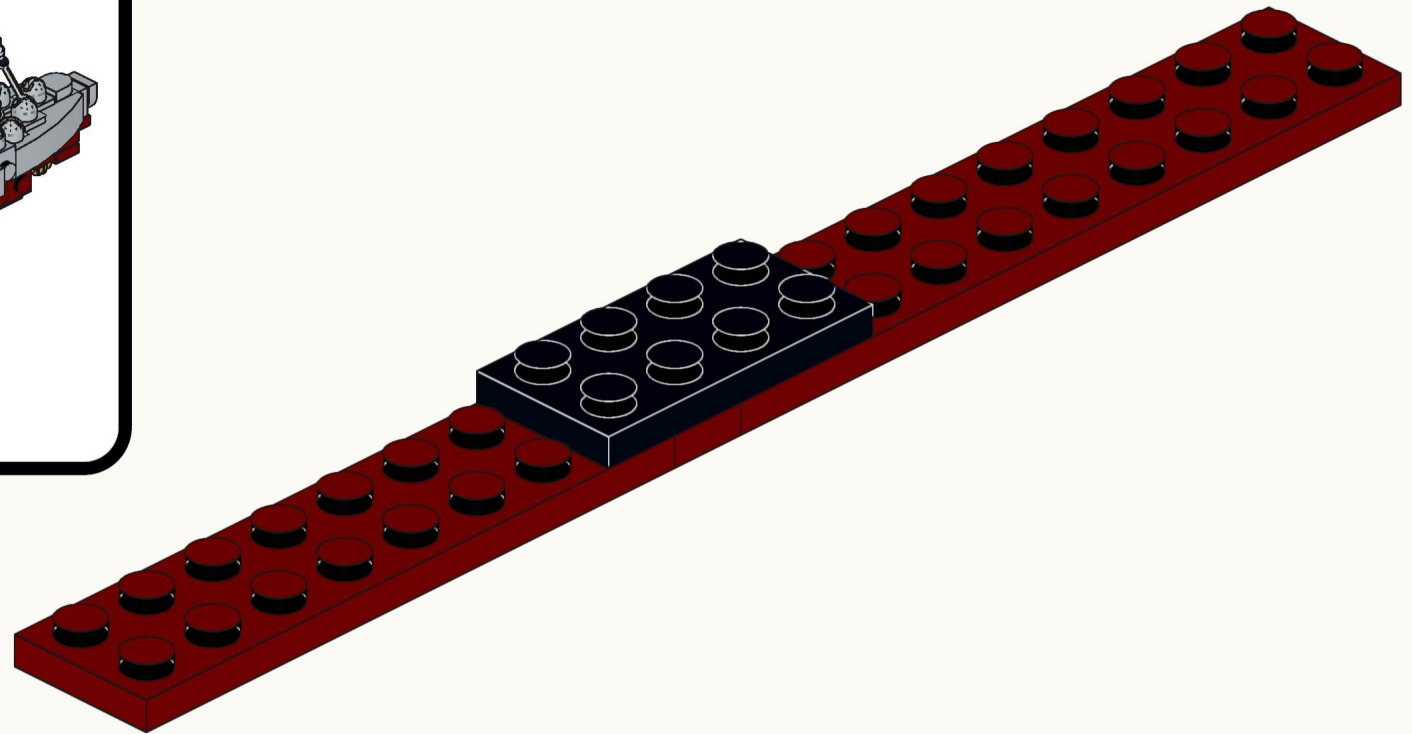

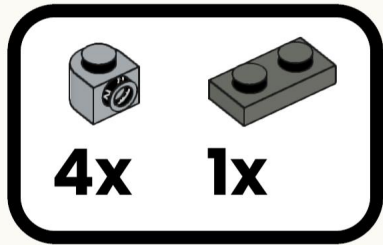

2

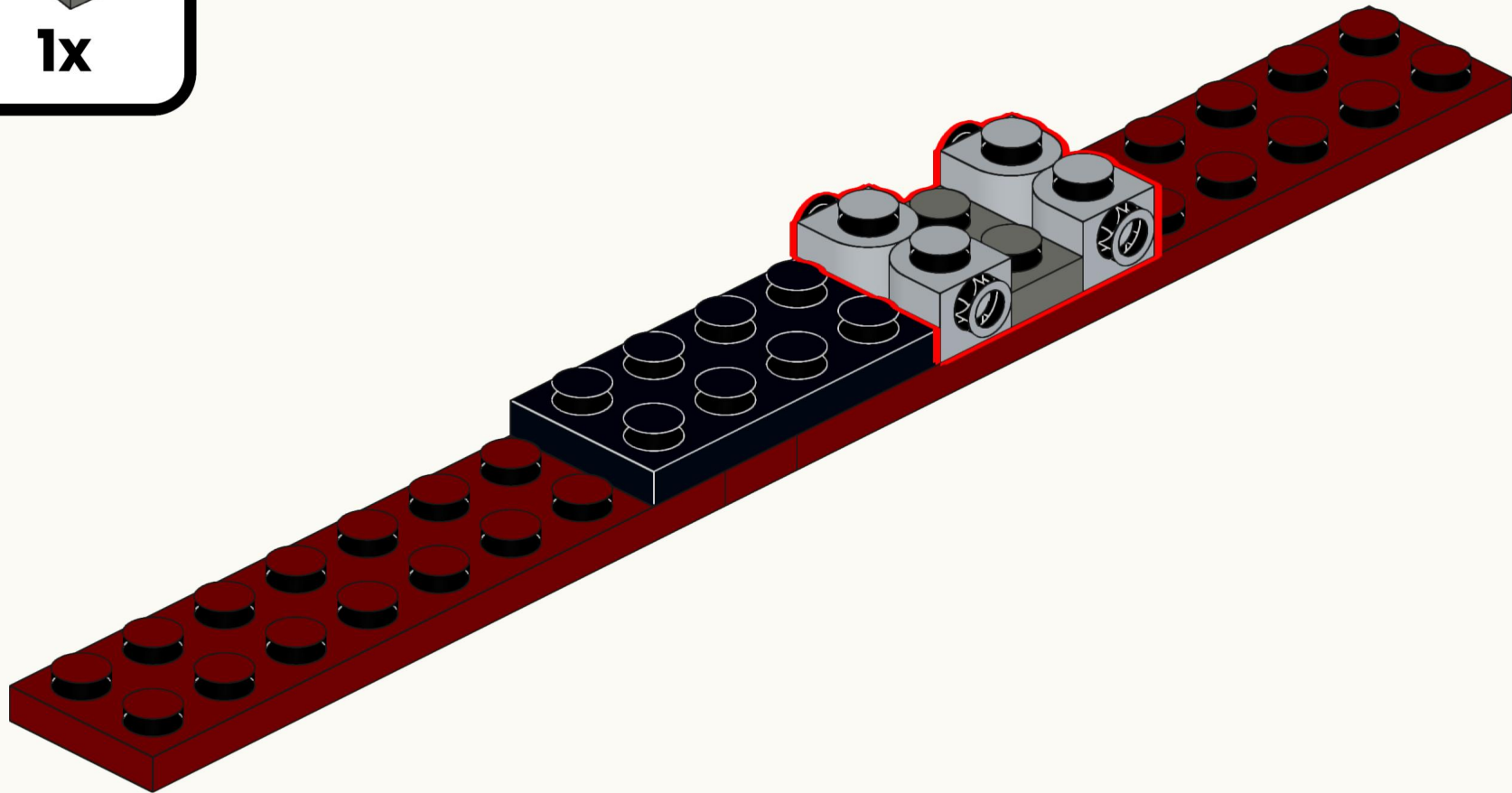

HMS Nelson was laid down on 28 December 1922 at Armstrong Whitworth's Low Walker shipyard in Newcastle upon Tyne. She was launched on 3 September 1925, and commissioned on 15 August 1927 at a cost of £7,504,055! An unprecedented amount, for a Royal Navy capital ship at the time.

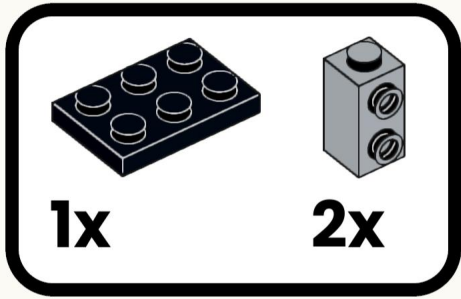

3

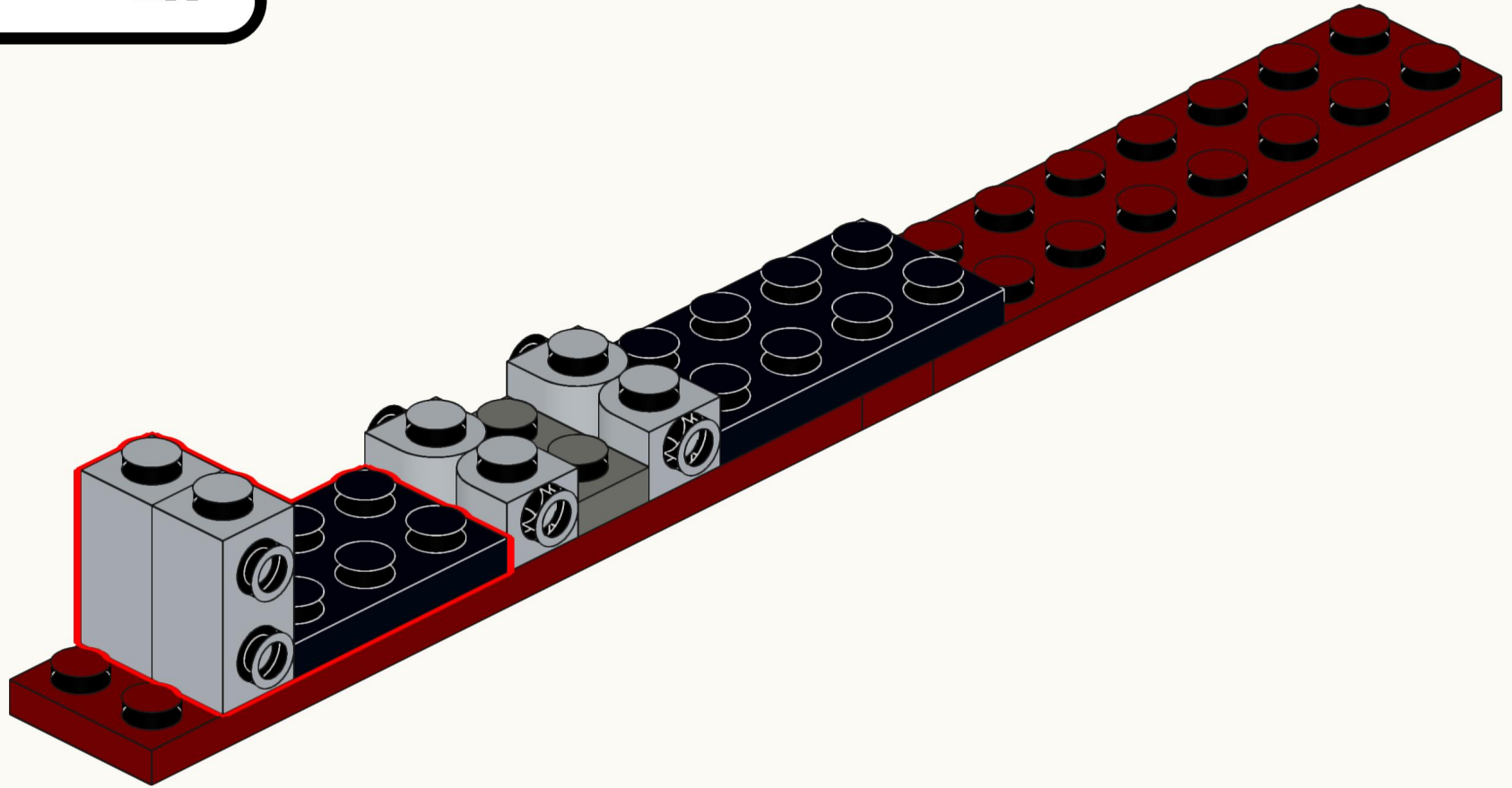

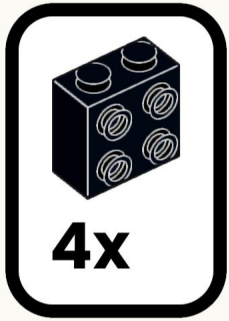

4

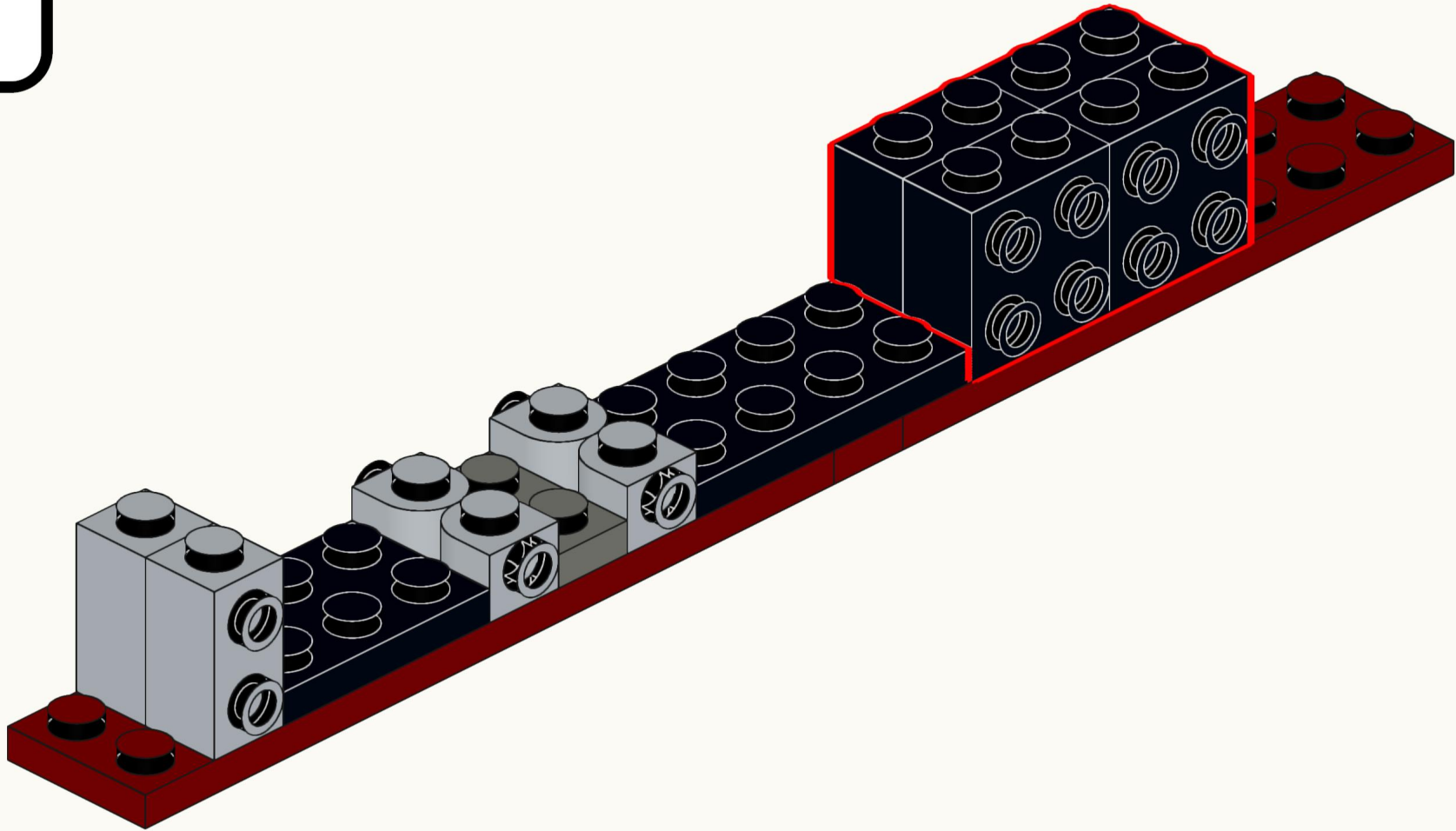

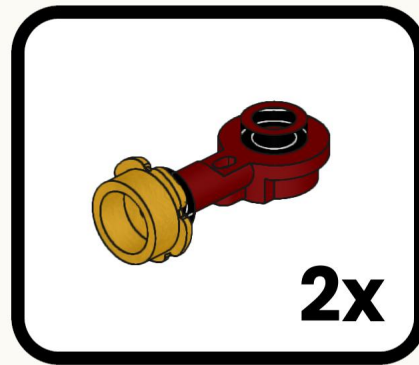
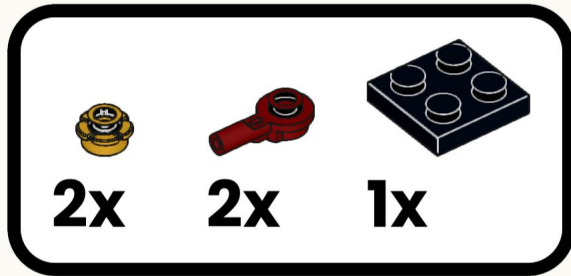

5

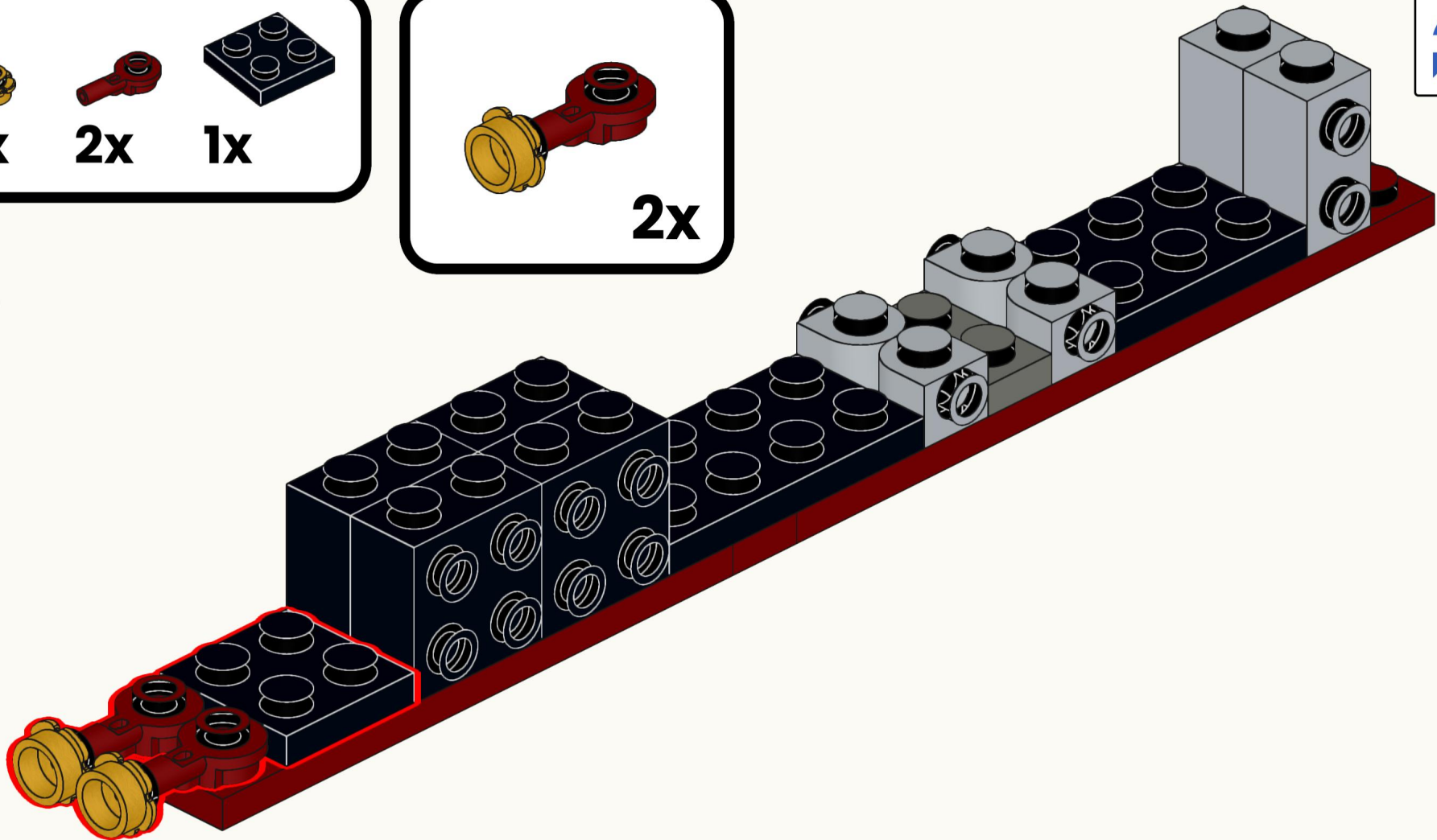

Nelson used only two propeller shafts. Every other British battleship from HMS Dreadnought in 1906 onwards had four, as did every British battleship class after Nelson. The two-shaft arrangement was forced by the need to save weight under treaty limits.

2x 2x 2x



6

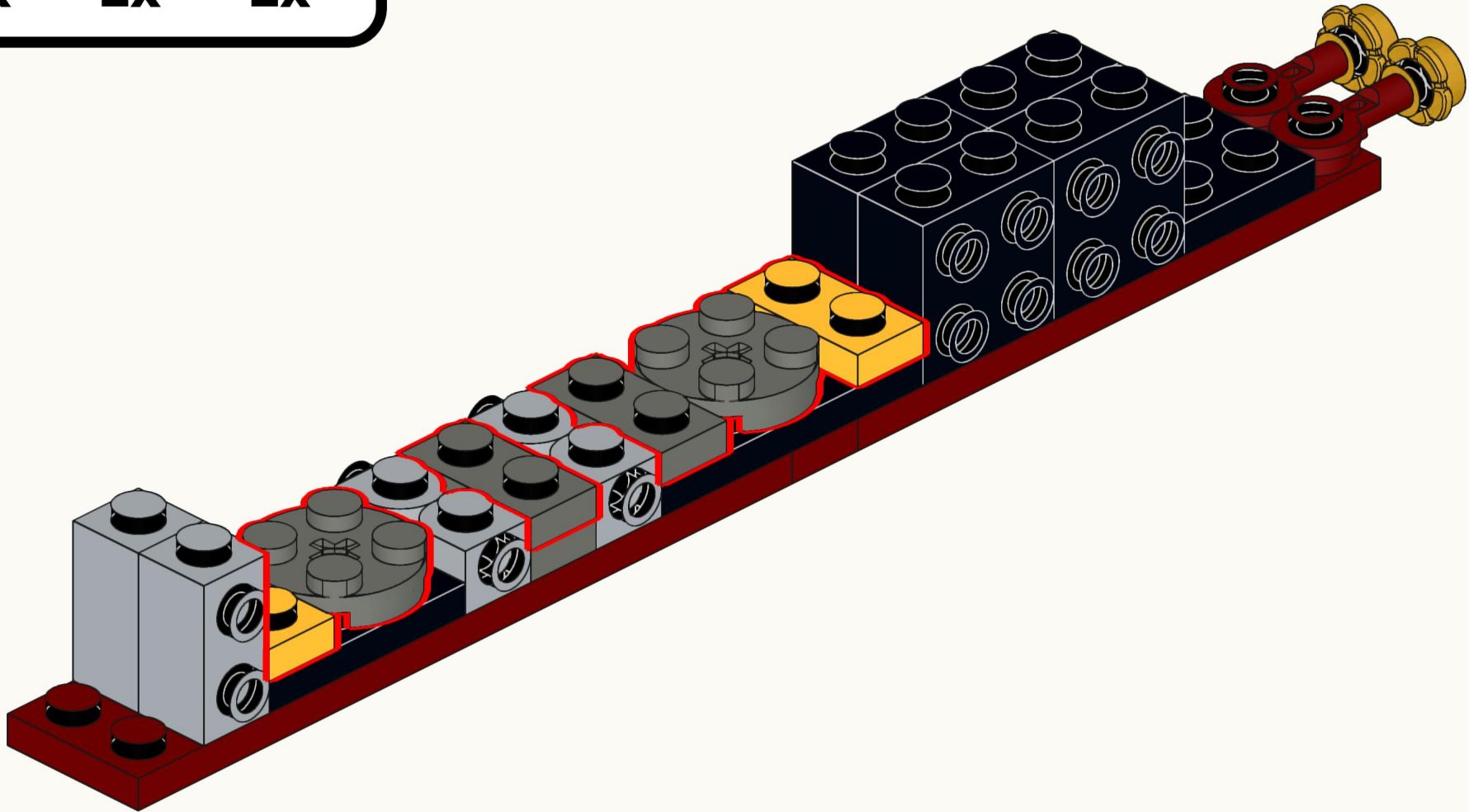

2x 1x 3x

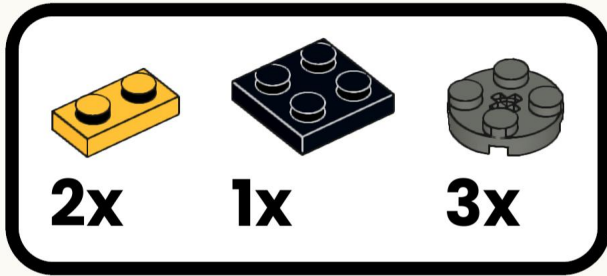

7

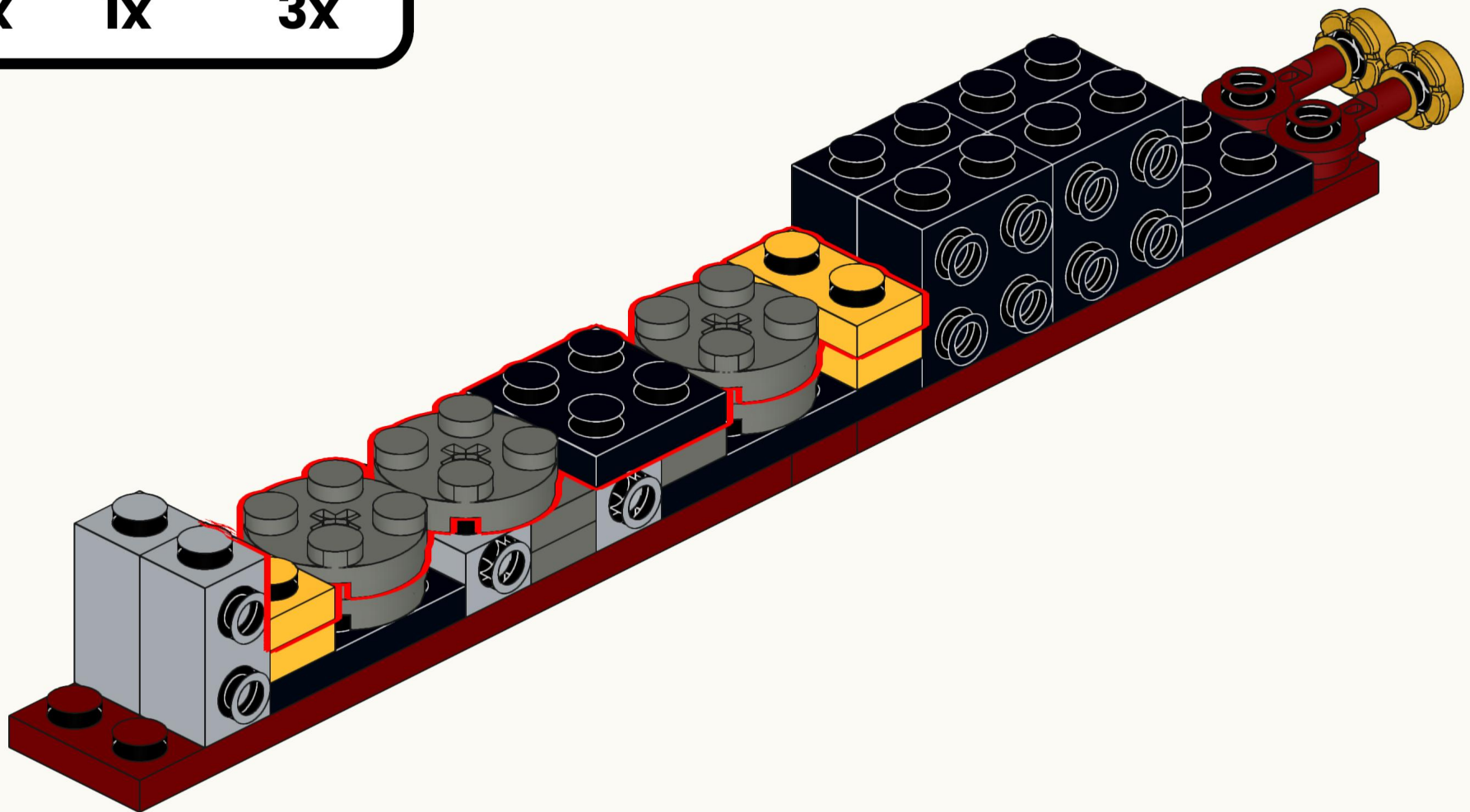

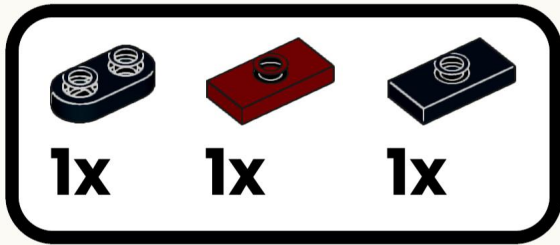

8

The boiler rooms were moved unusually aft of the engine rooms so that exhaust gases could be kept well clear of the superstructure and vented through a single funnel, which also helped shorten the armoured citadel.

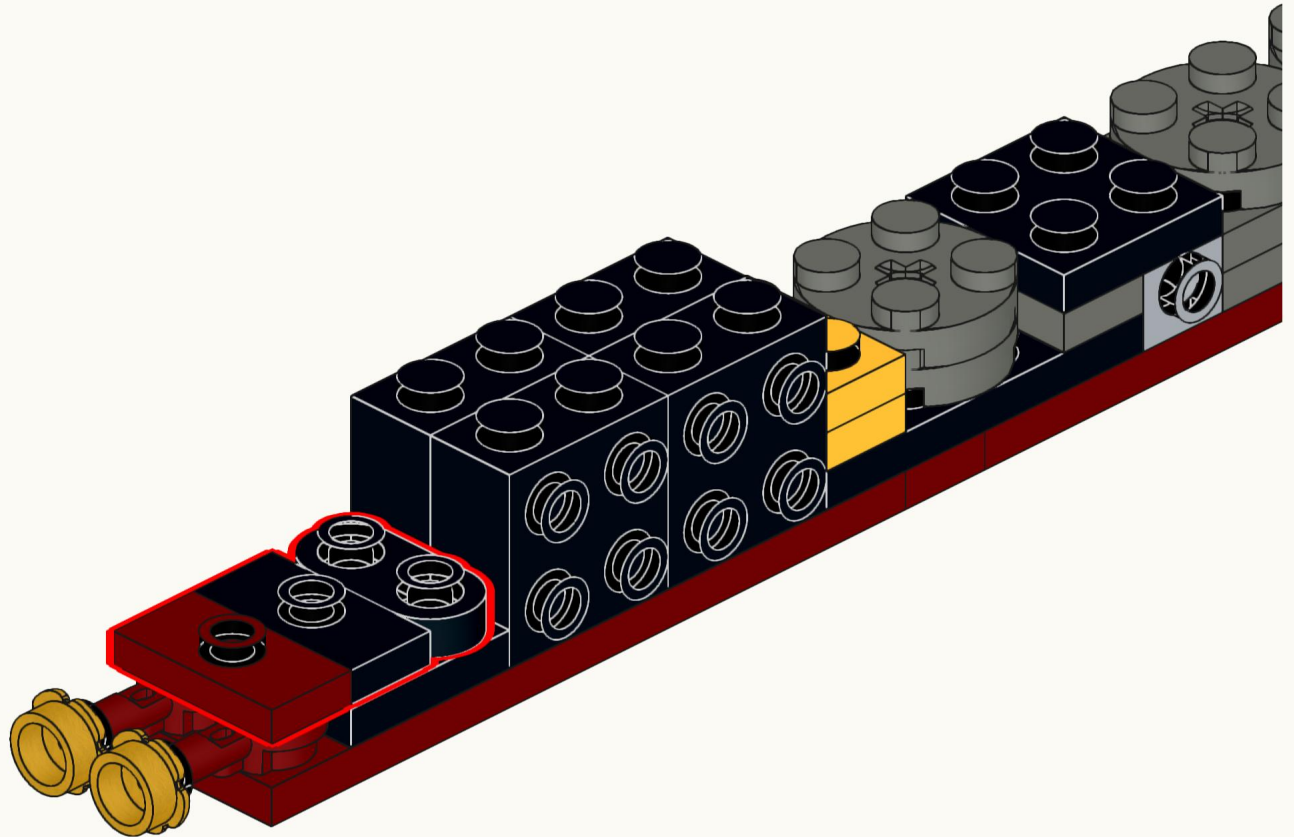

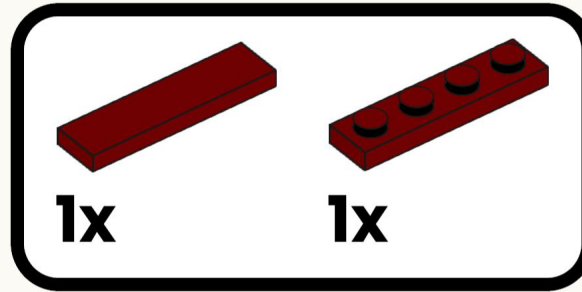
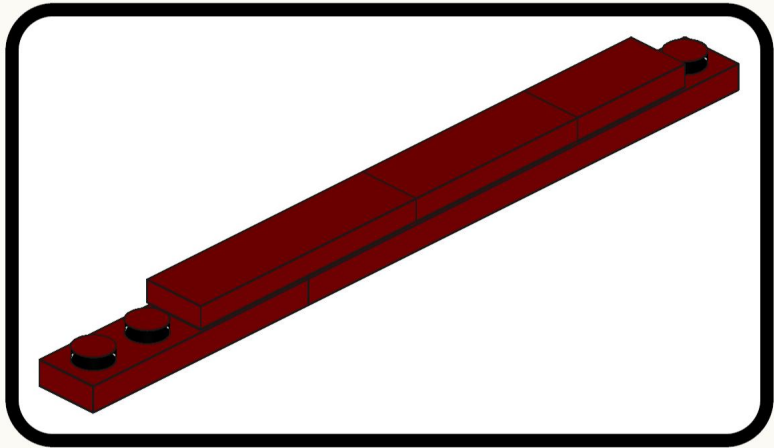

10

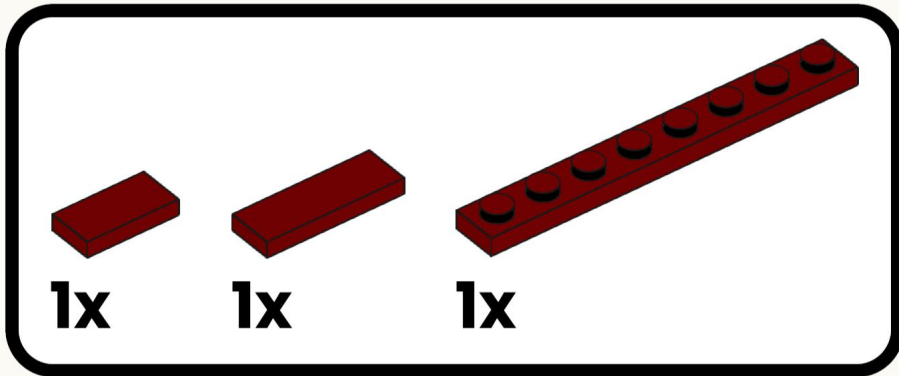

9

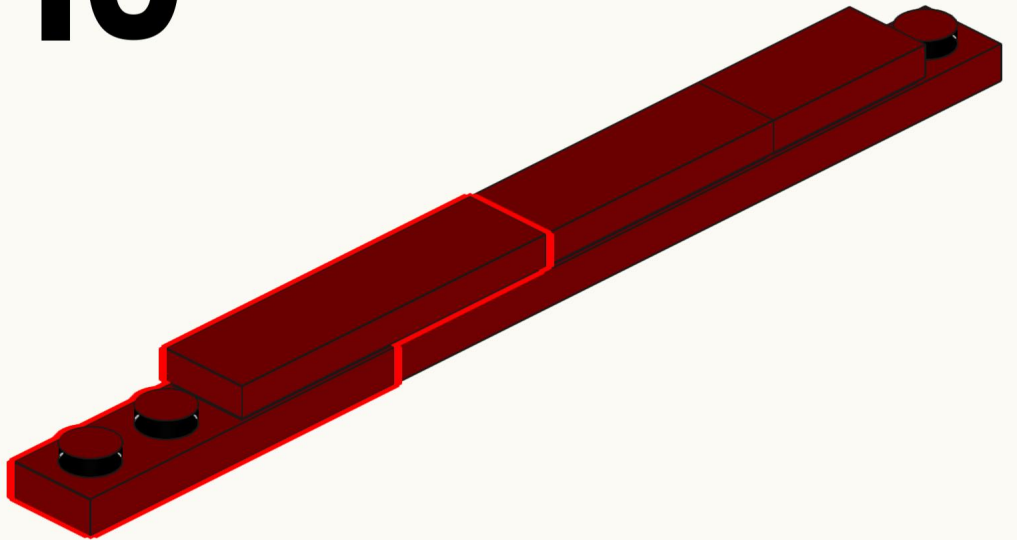
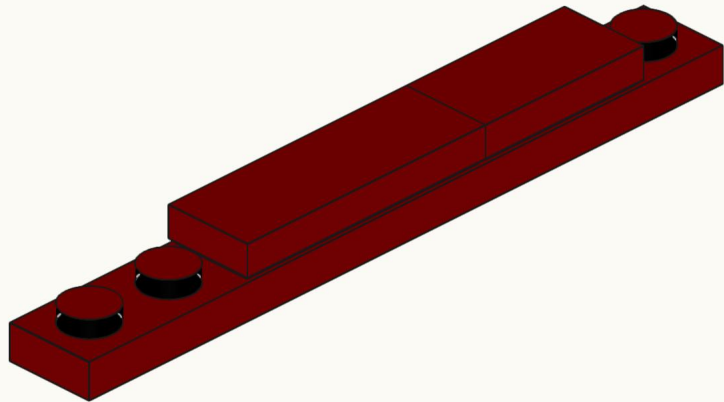

11

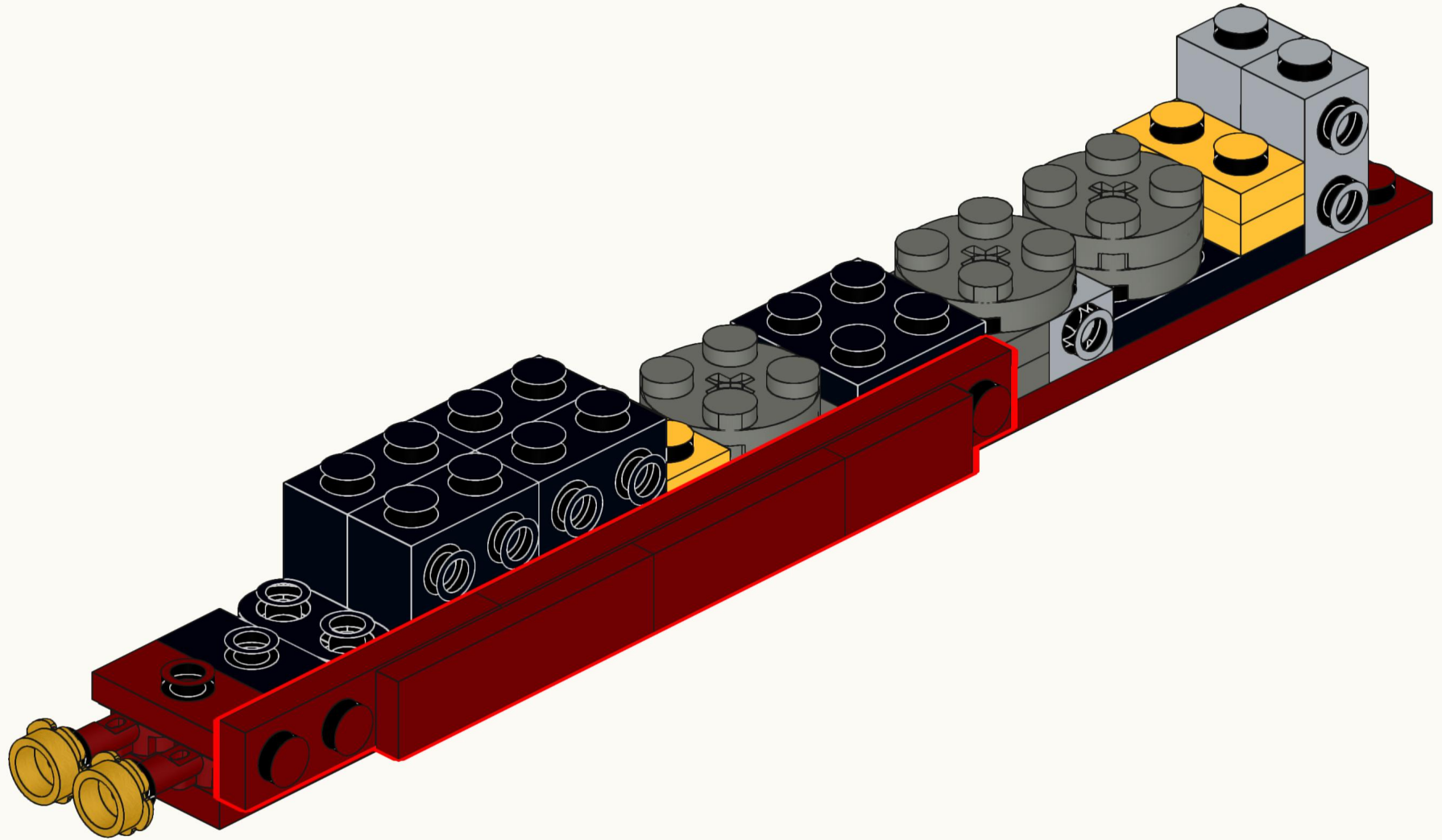

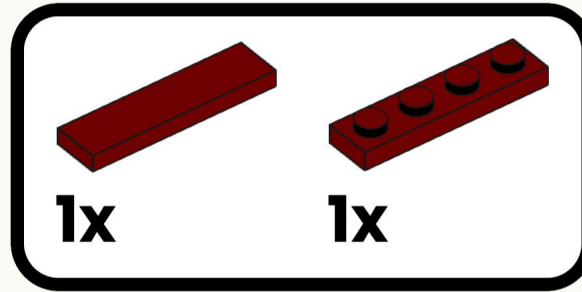
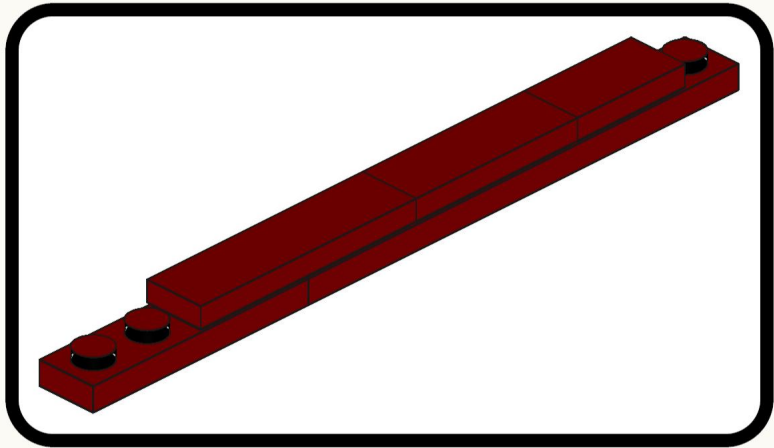

**13**

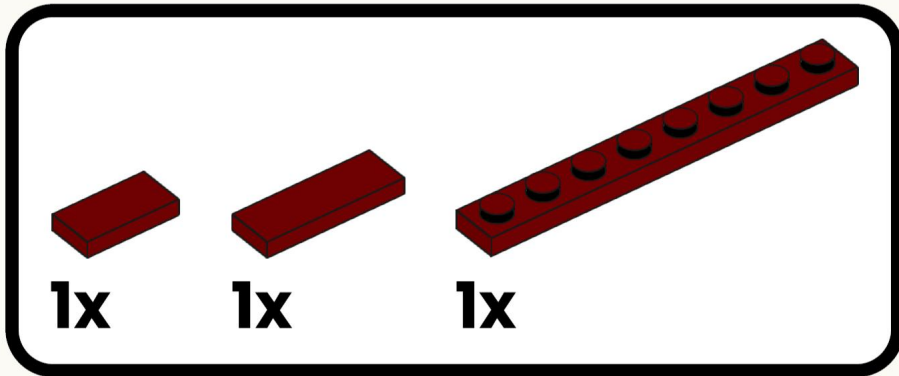

**12**

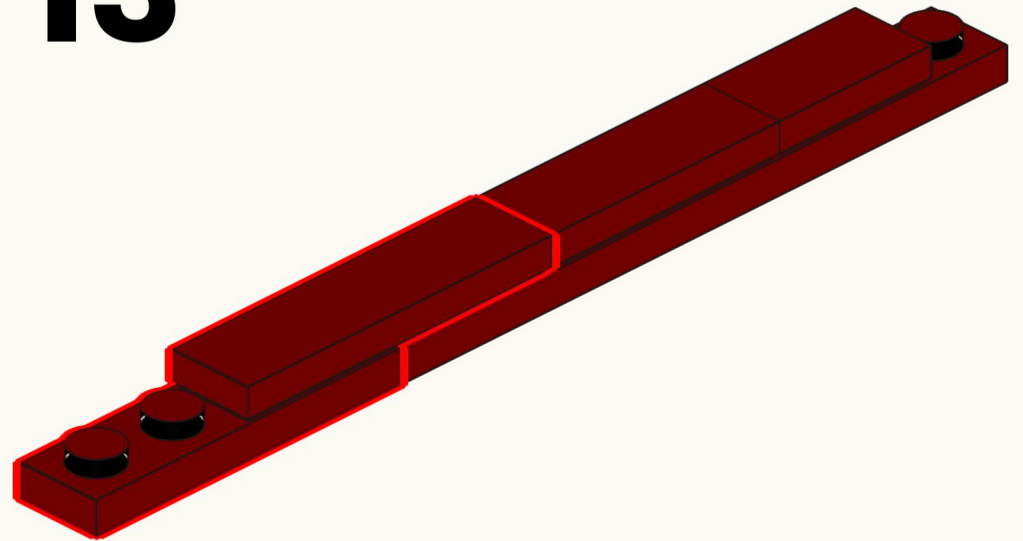
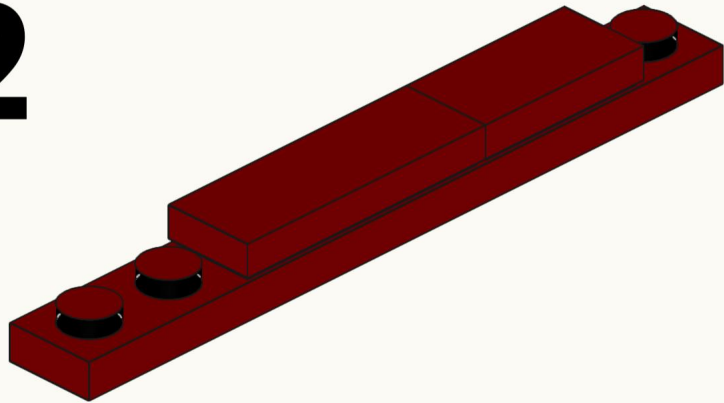

# 14

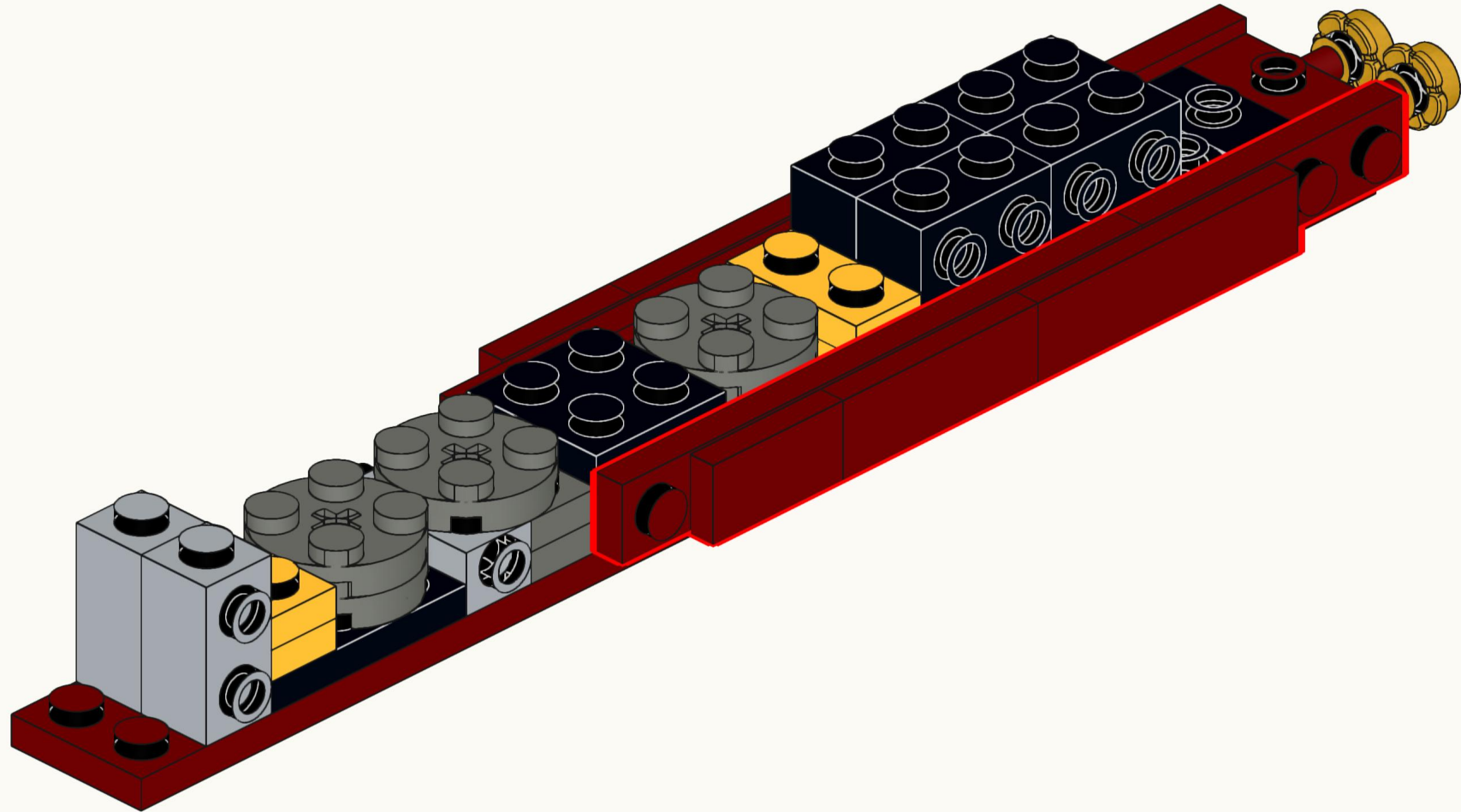

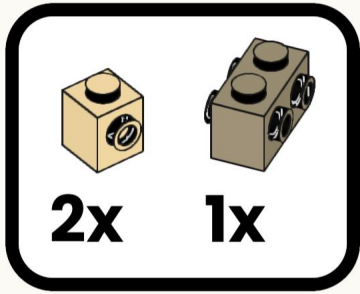

15

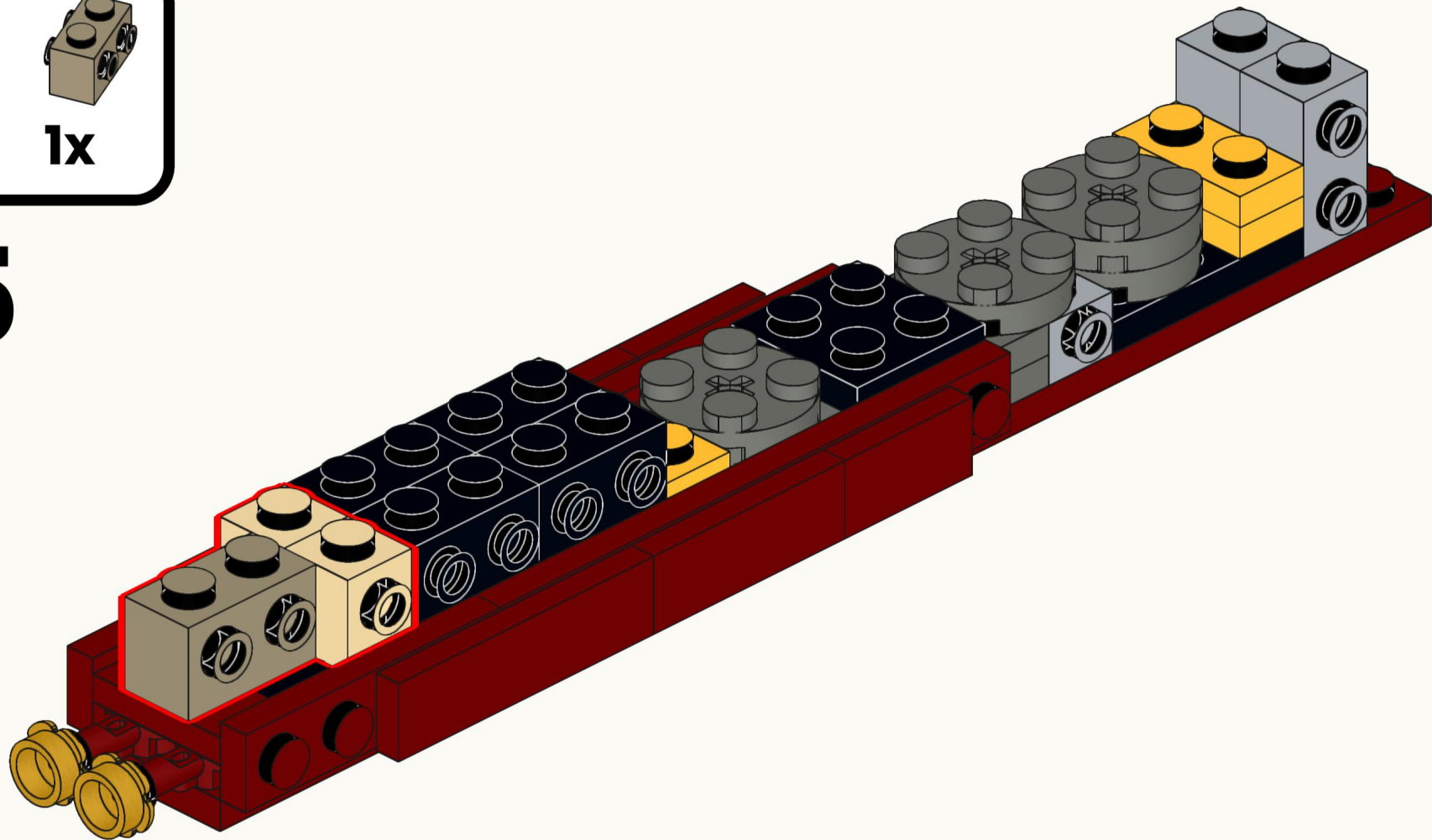

Underwater protection was provided by a double bottom five feet deep and an internal torpedo defence system with a total depth of 12 feet, rated to withstand an explosion of 750 lbs of TNT!

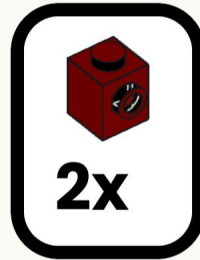
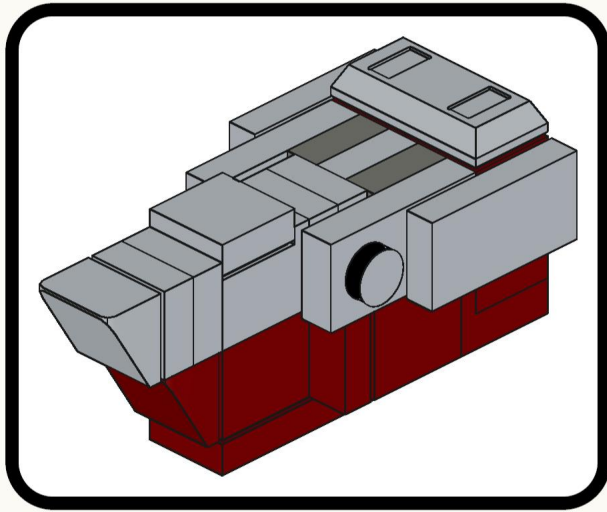

17

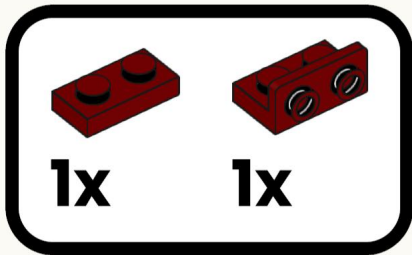

16

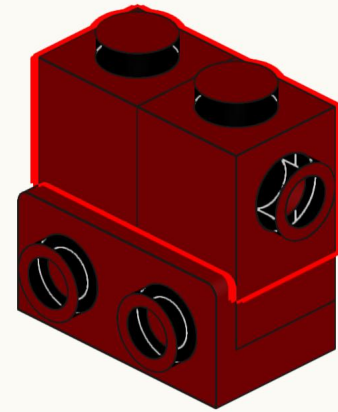
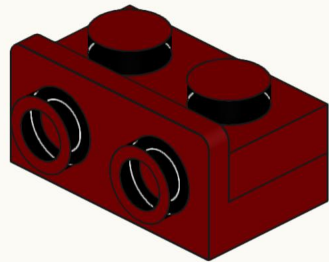

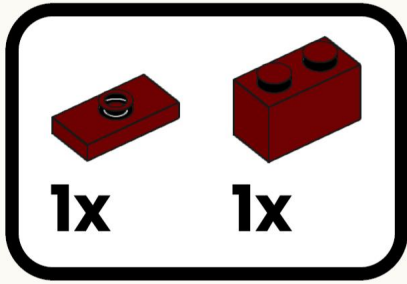

18

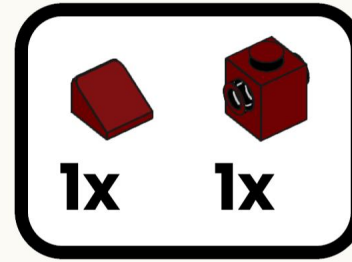
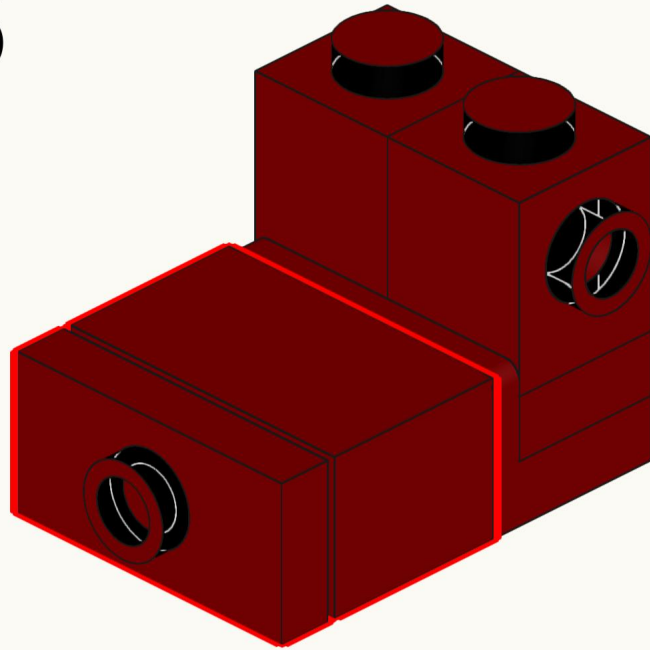

19

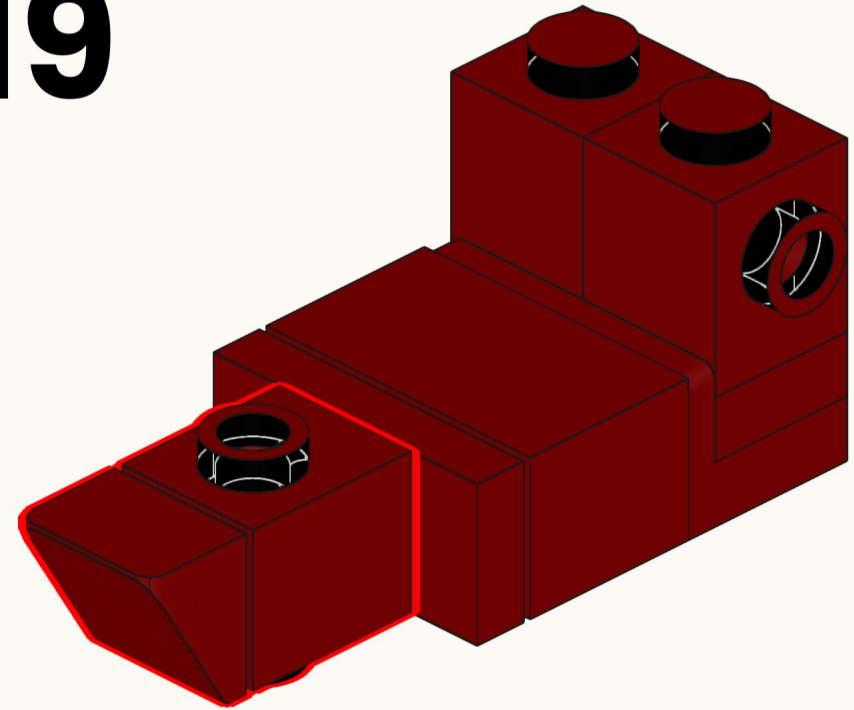

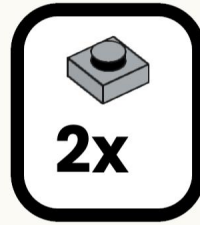
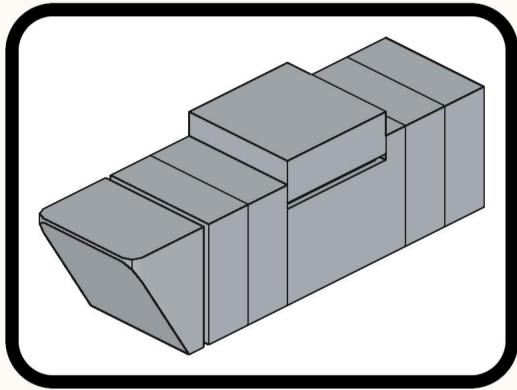

2x

21

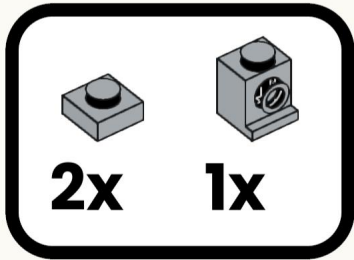

2x

1x

20

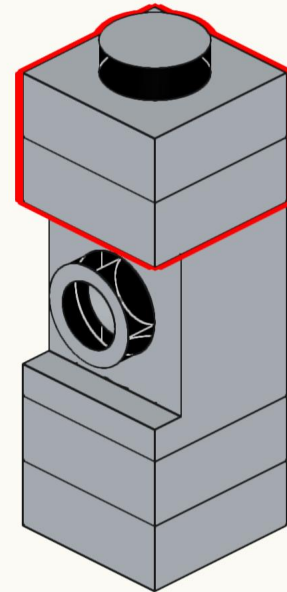
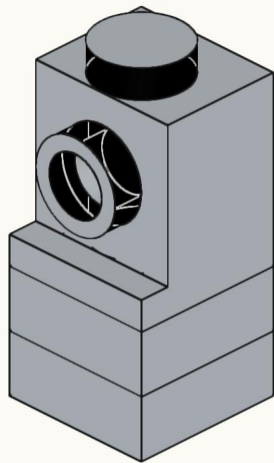

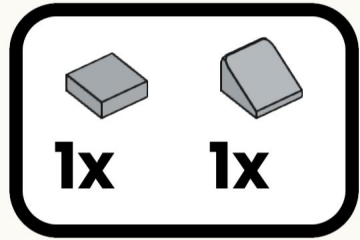

22

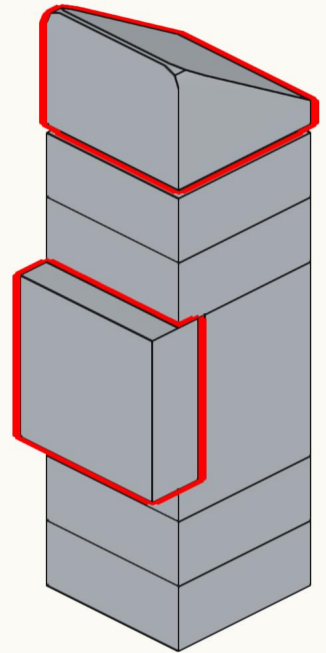

23

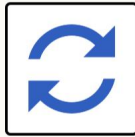
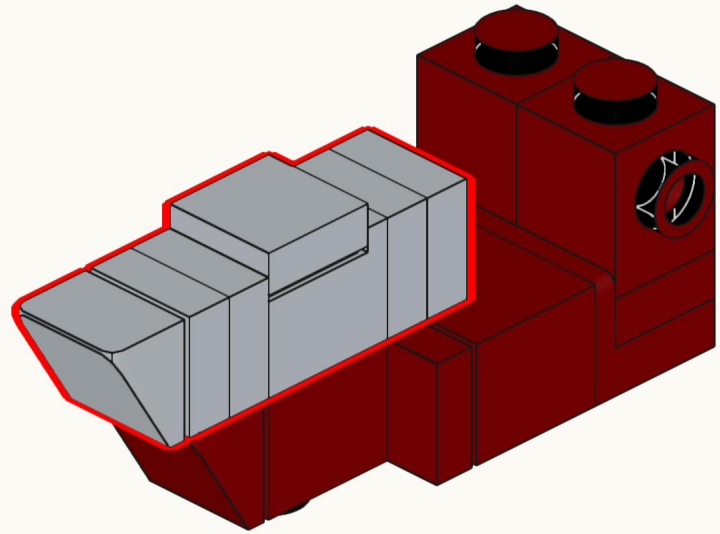

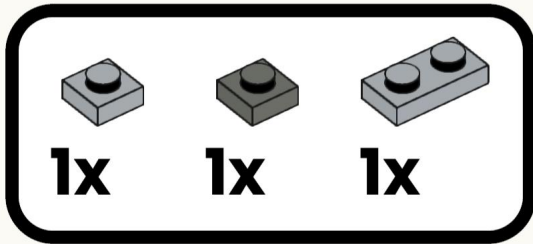
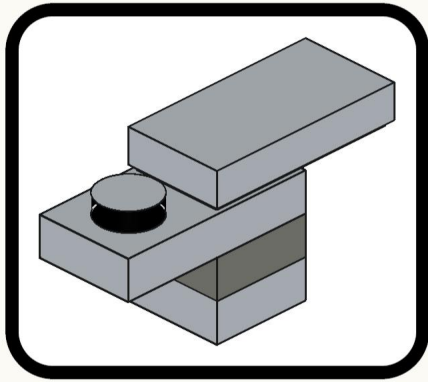

**24**

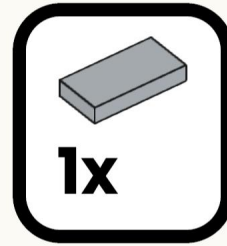
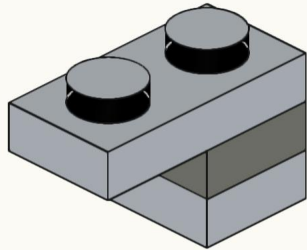

**25**

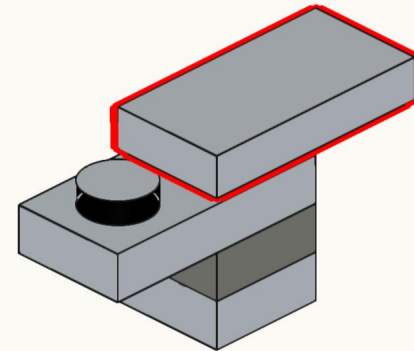

# 26

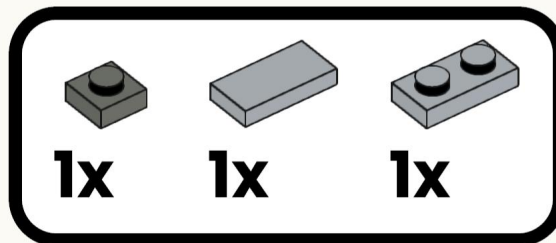
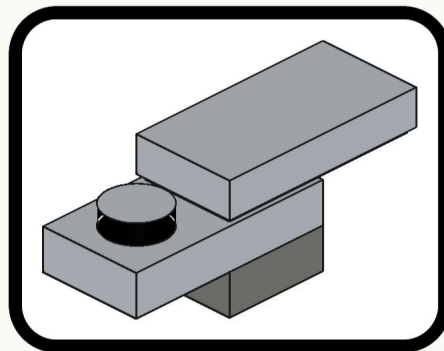
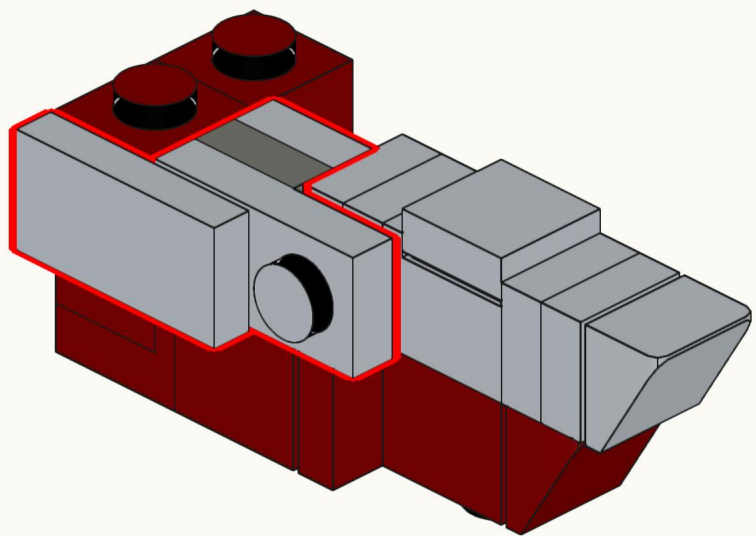

# 27

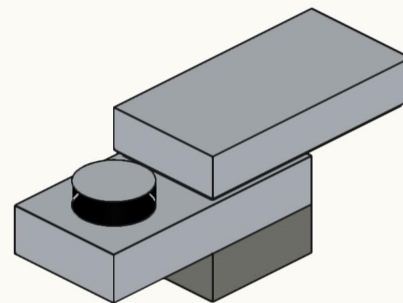

# 28

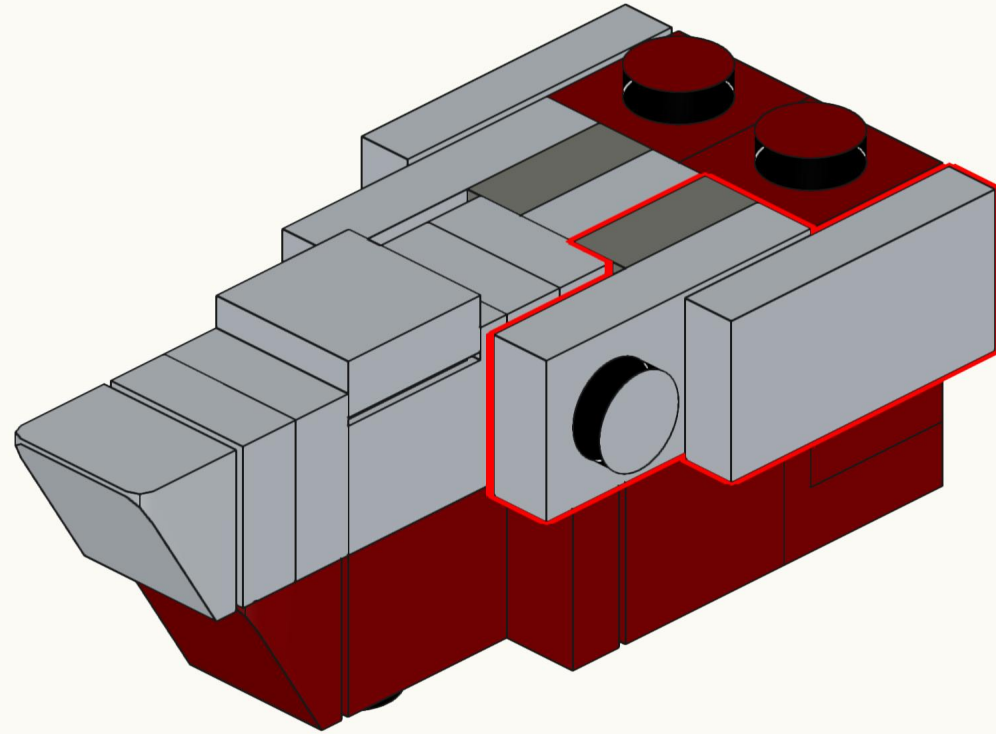

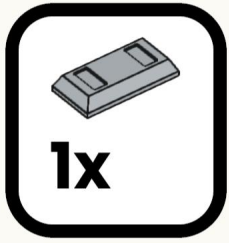

29

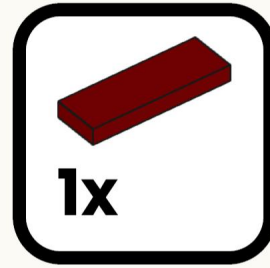
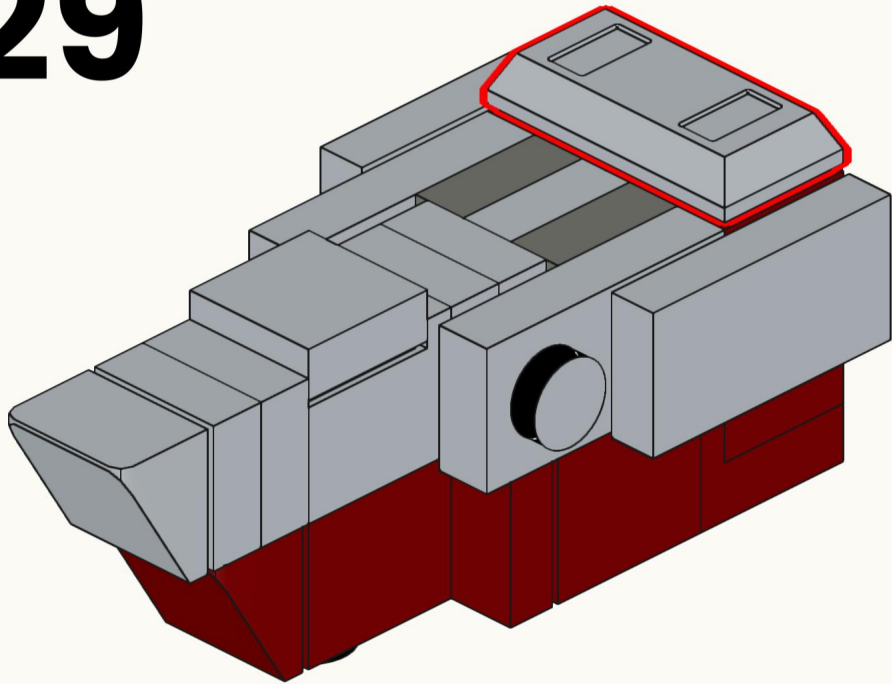

30

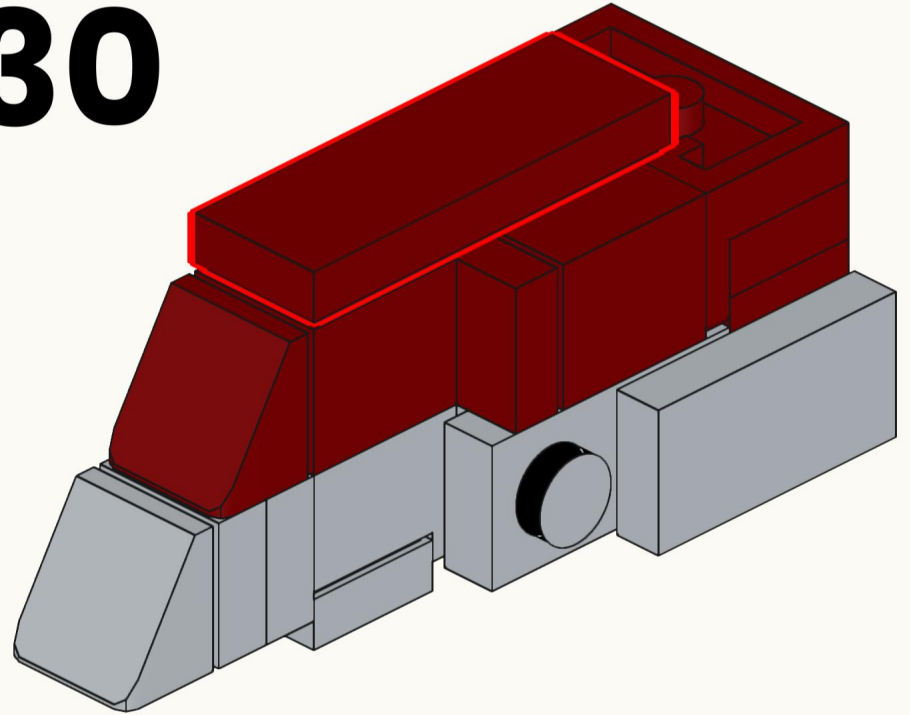



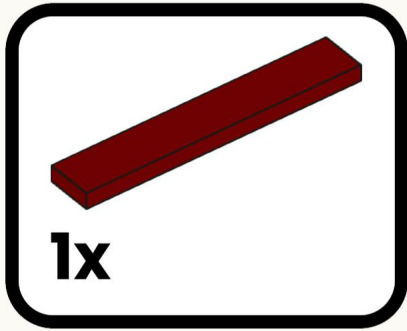

32

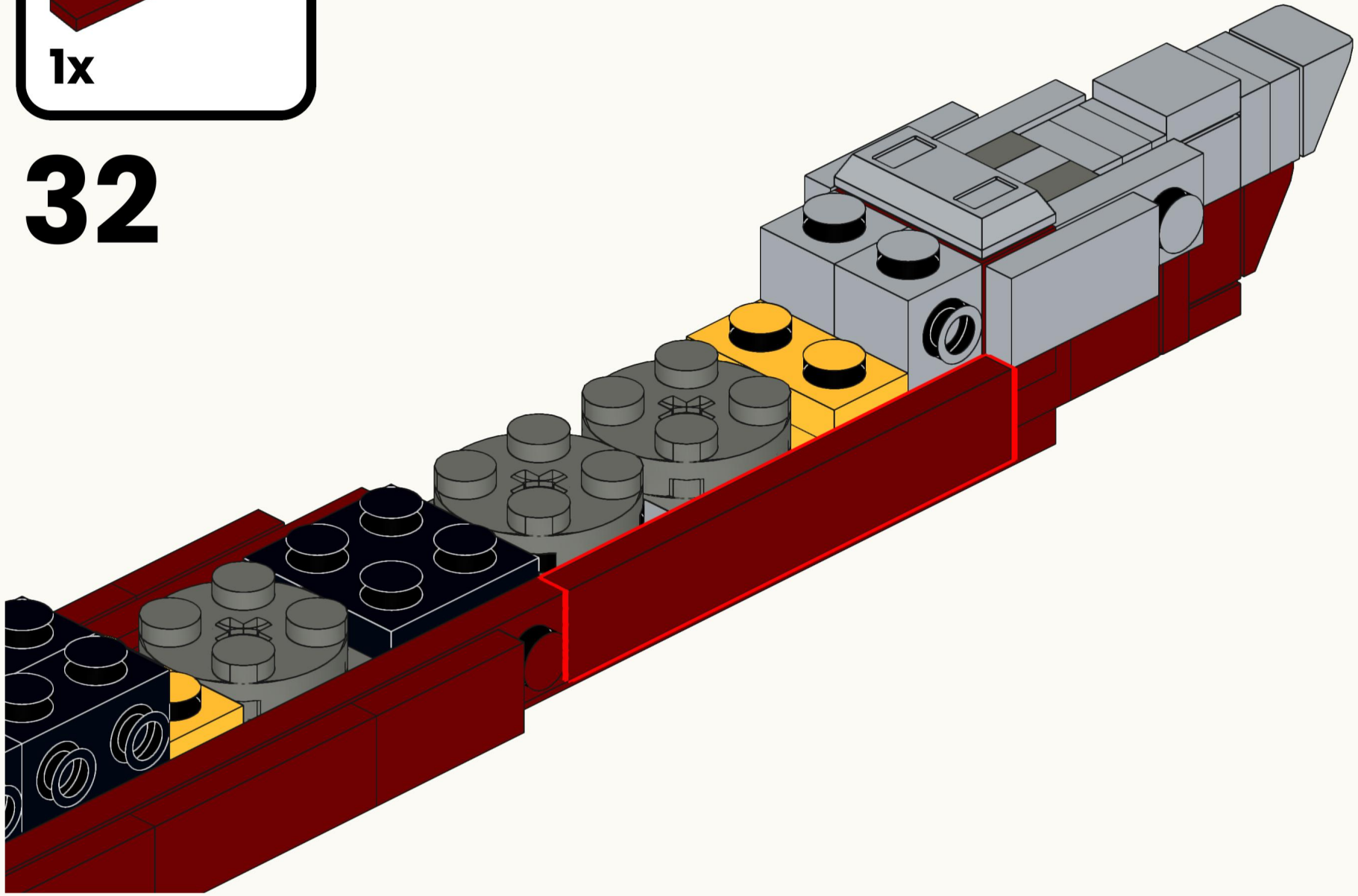

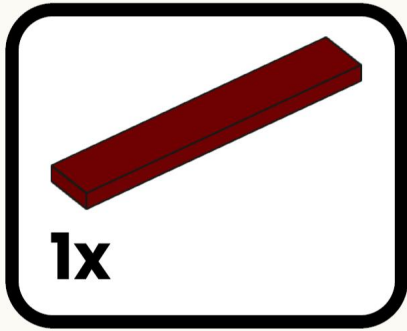

**33**

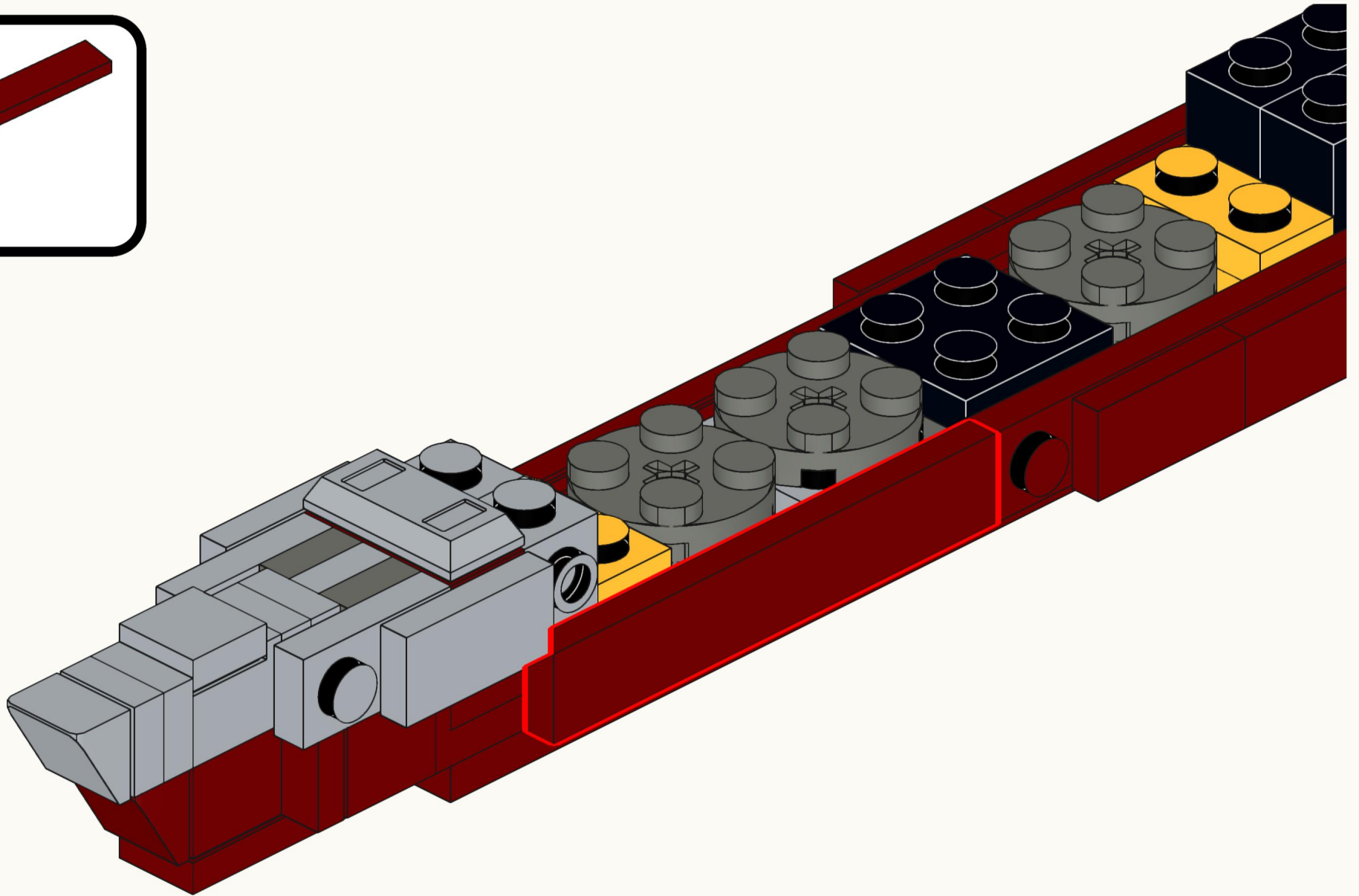

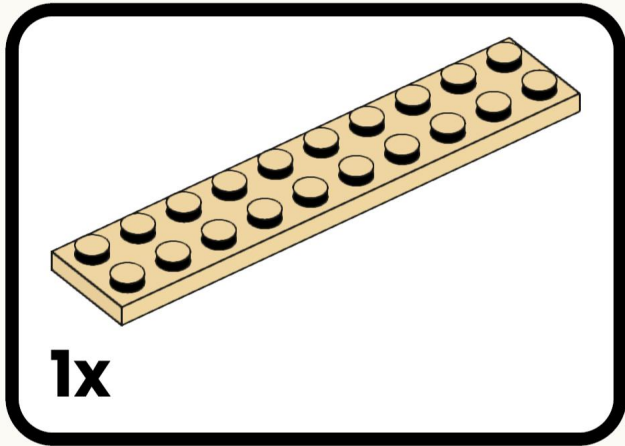

34

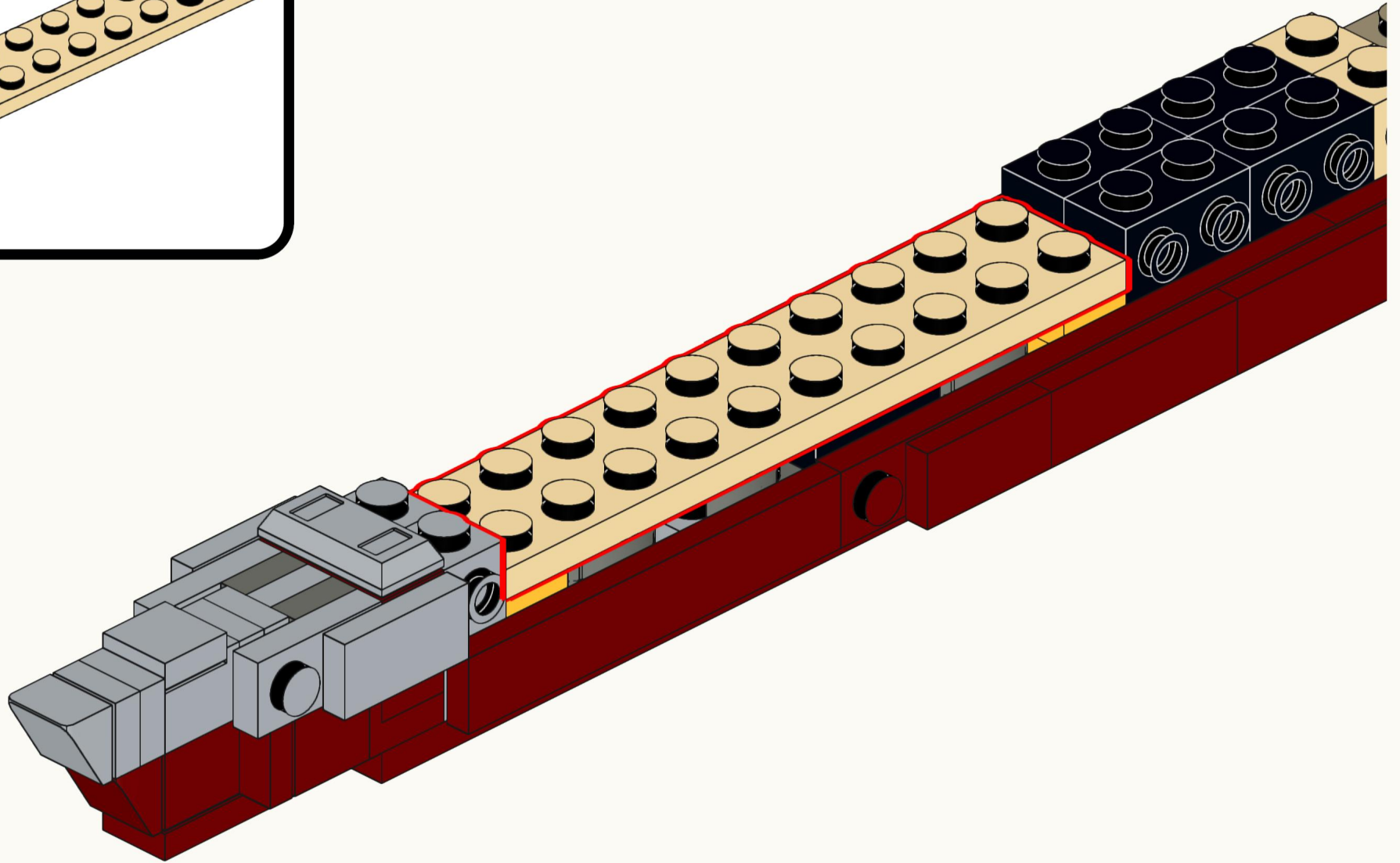

2x 1x 2x

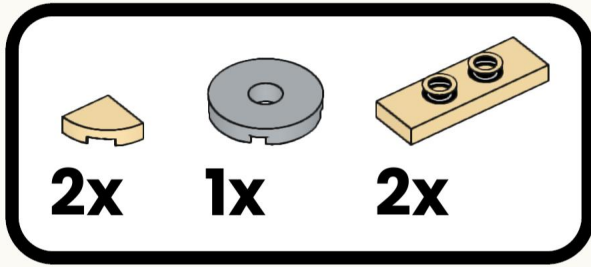

35

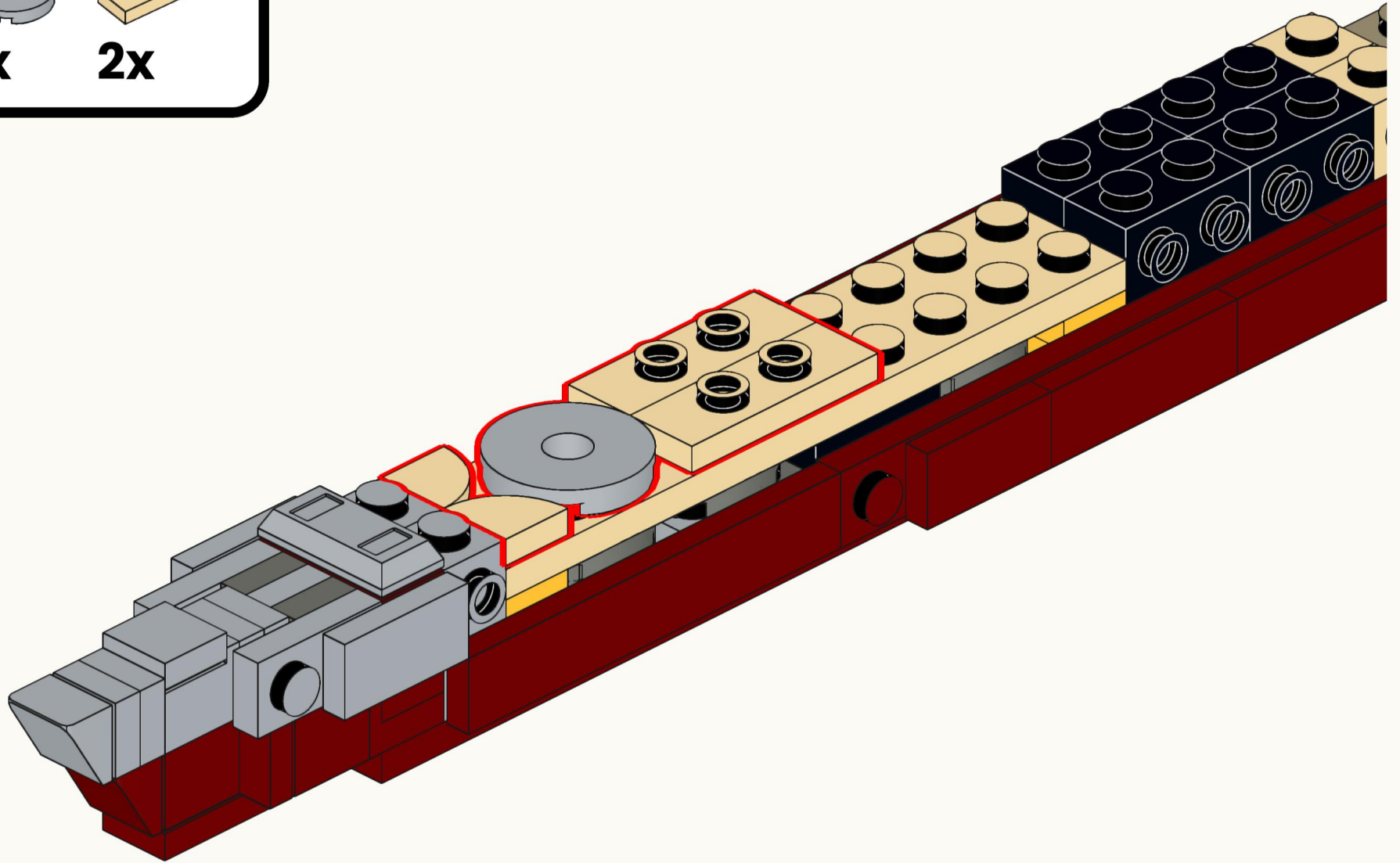

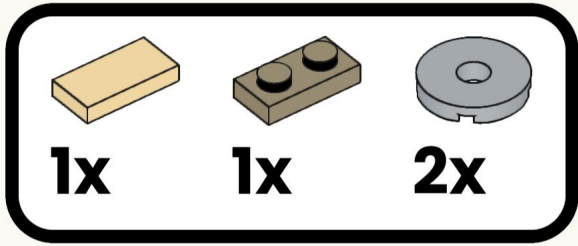

36

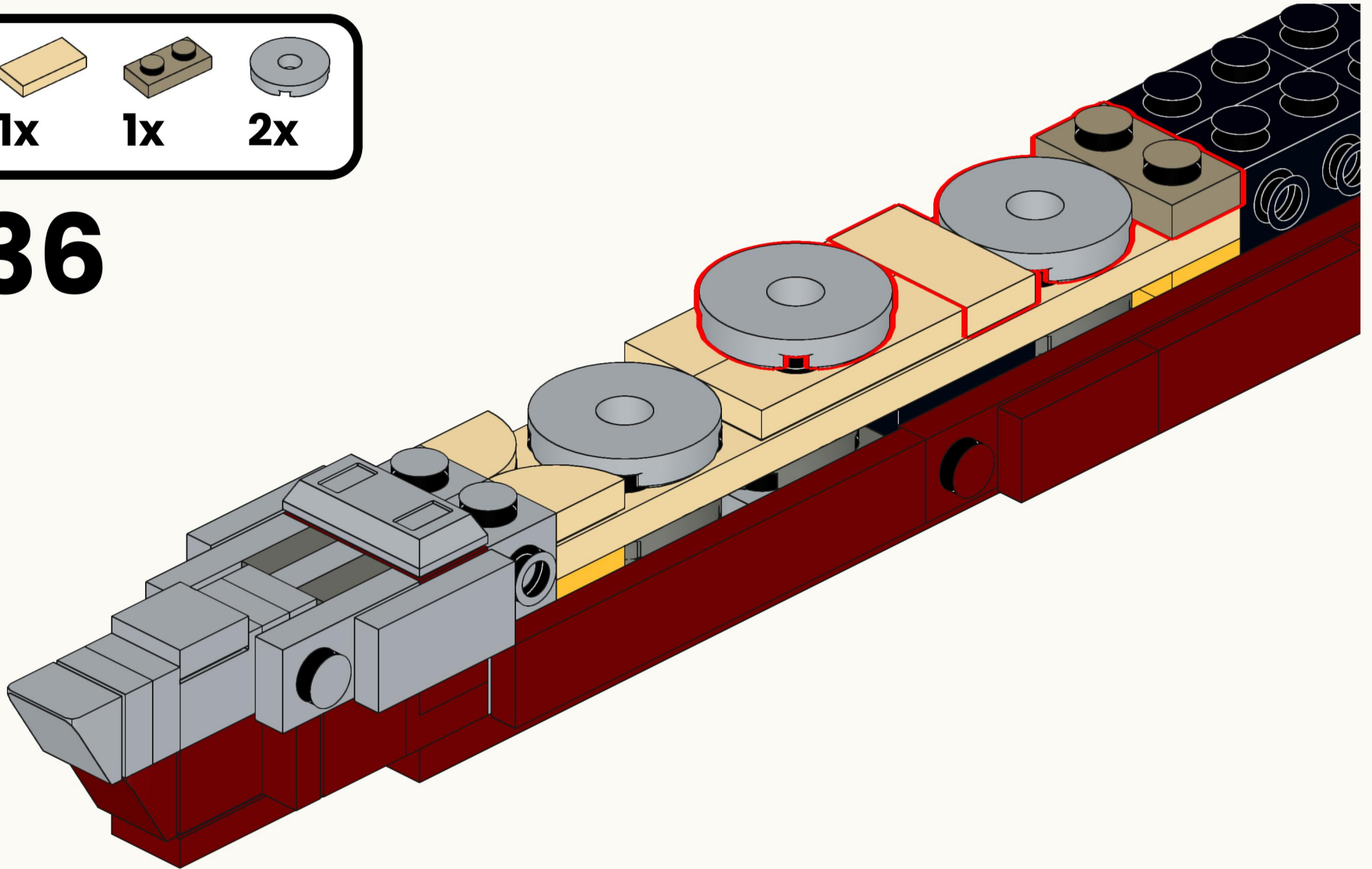

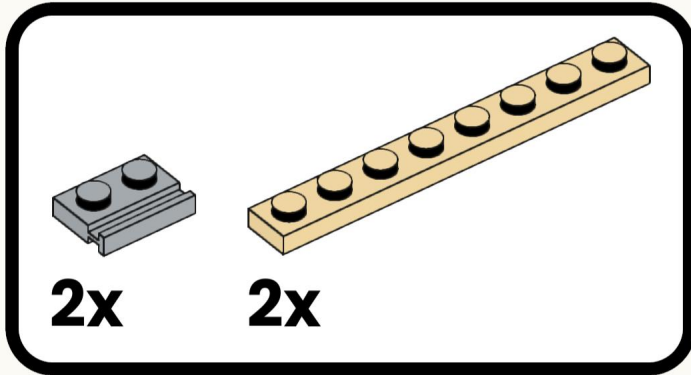
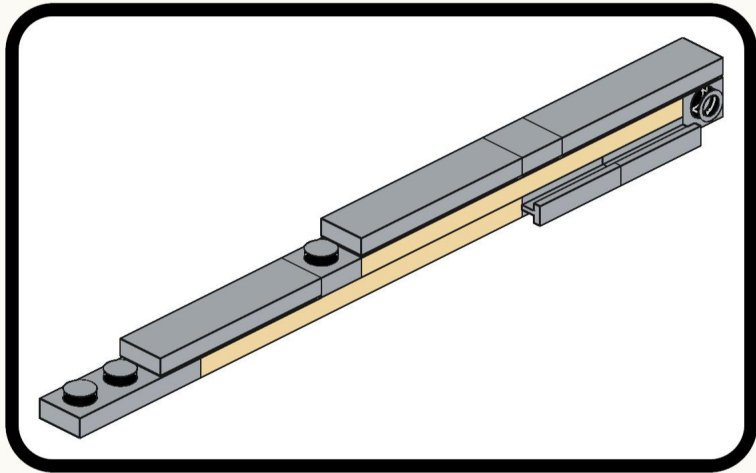

**37**

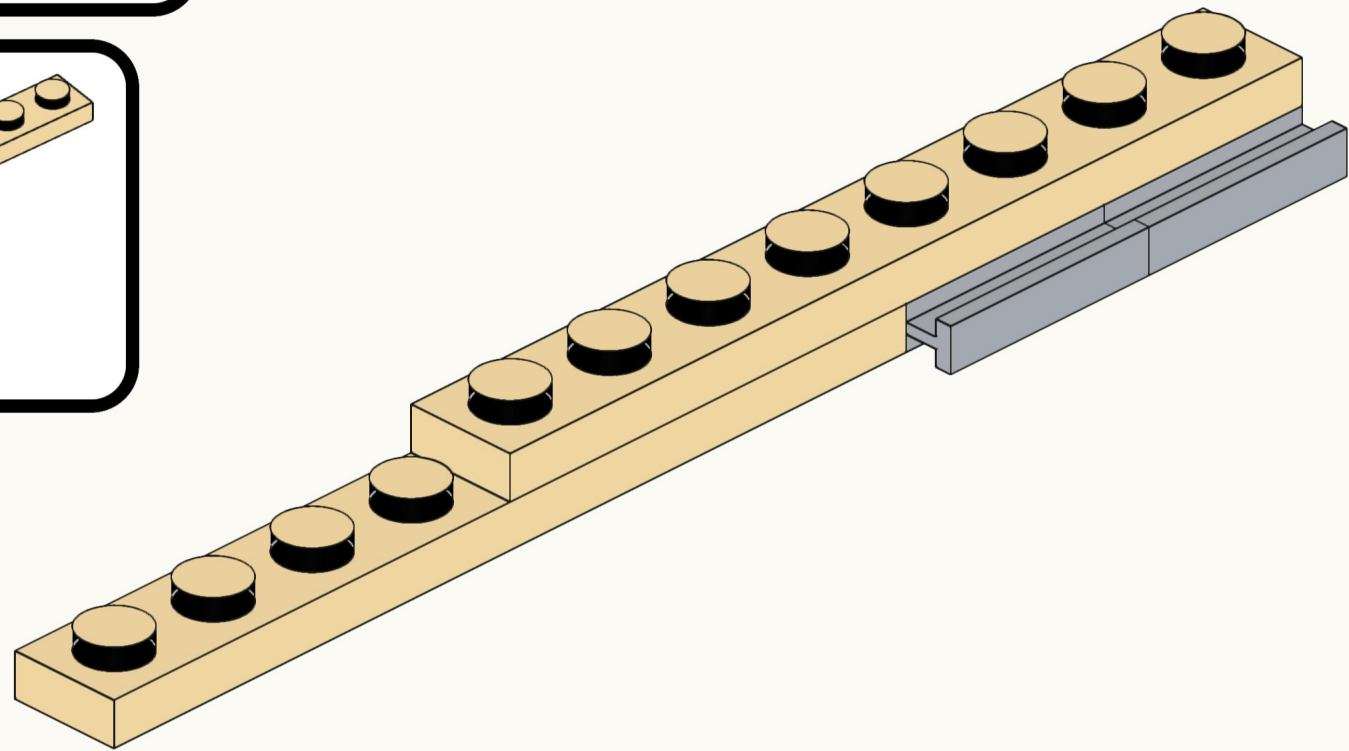

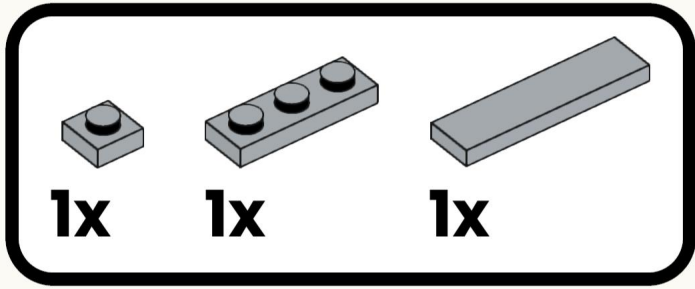

38

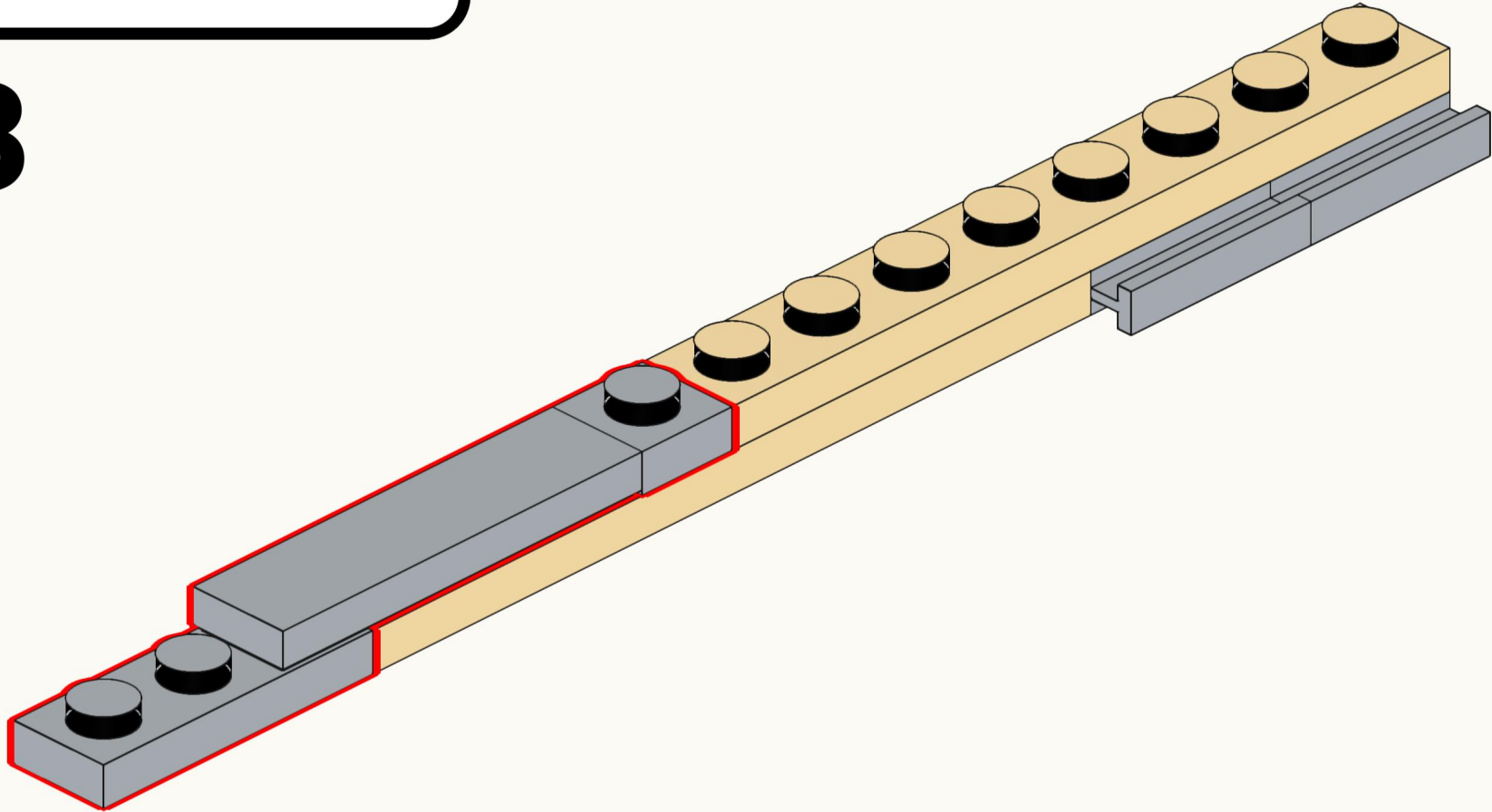

1x 1x 2x



39

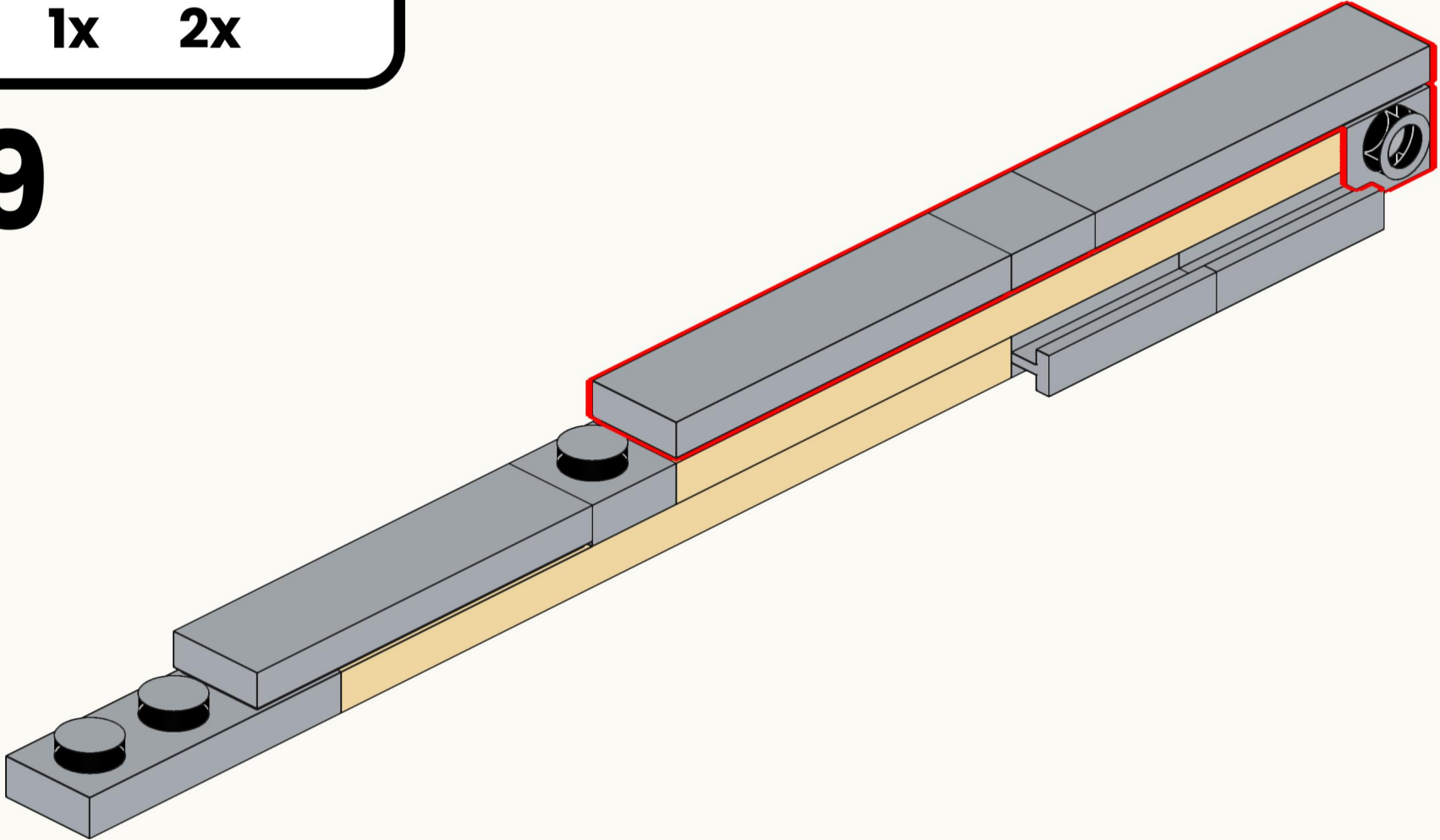

# 40

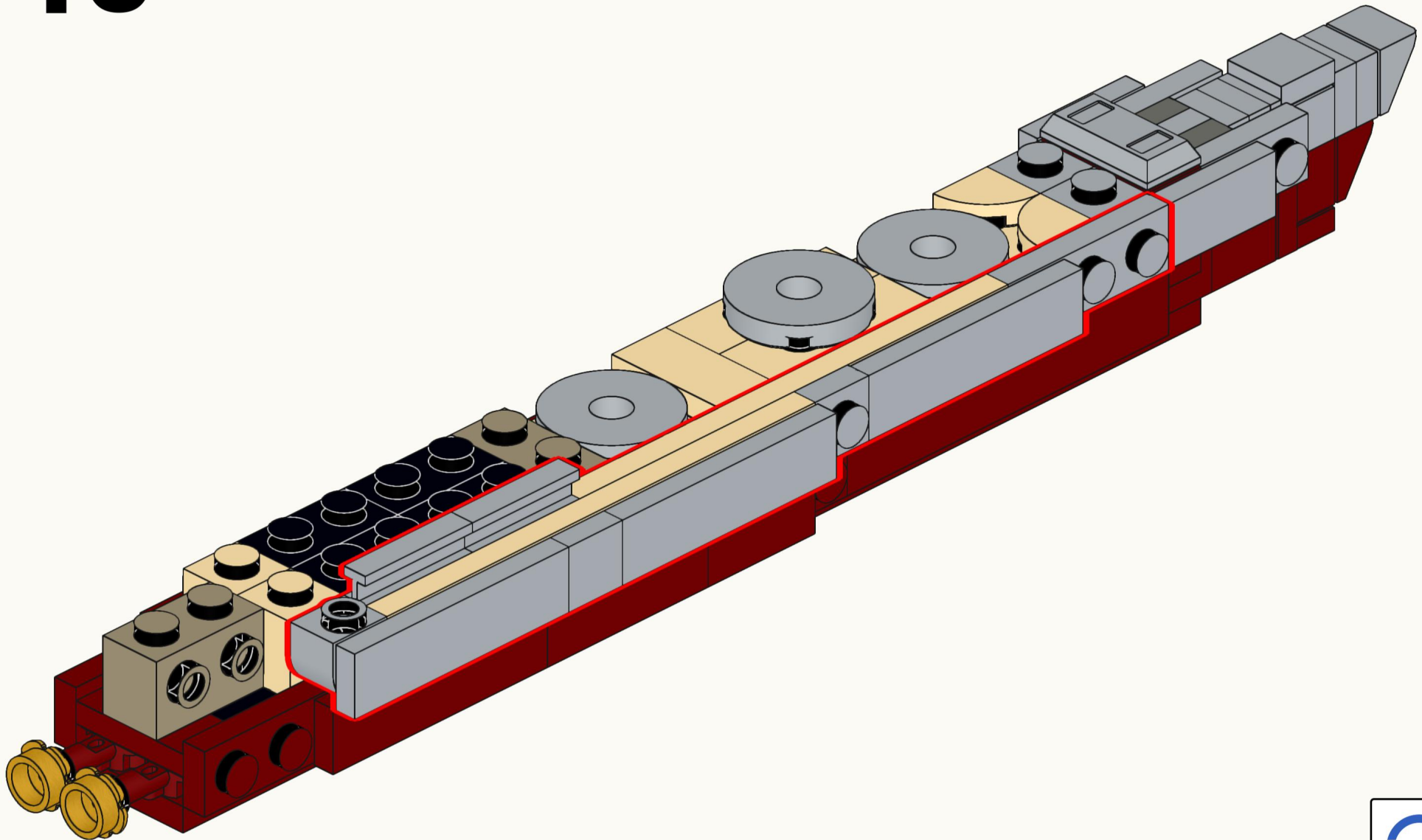

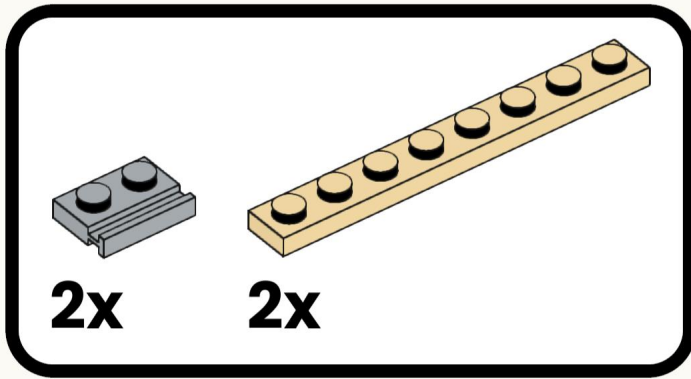
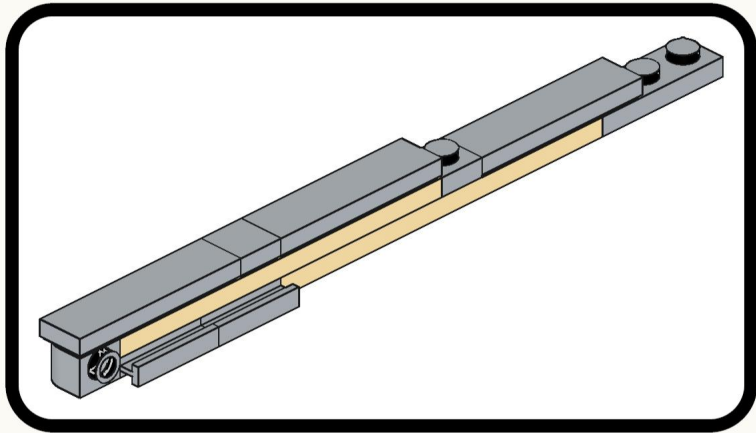

**41**

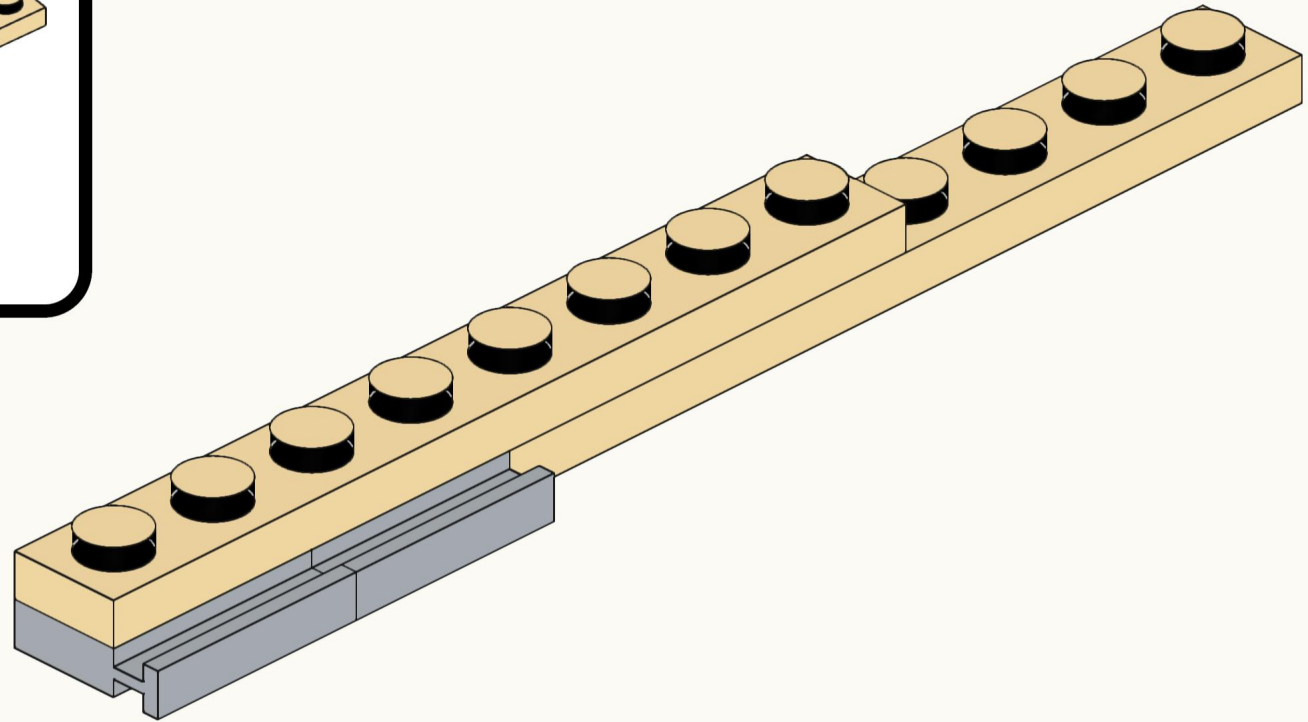

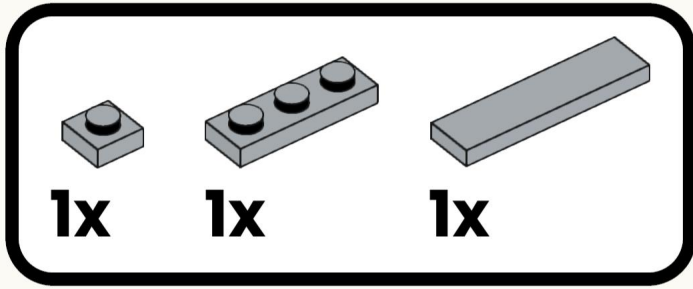

42

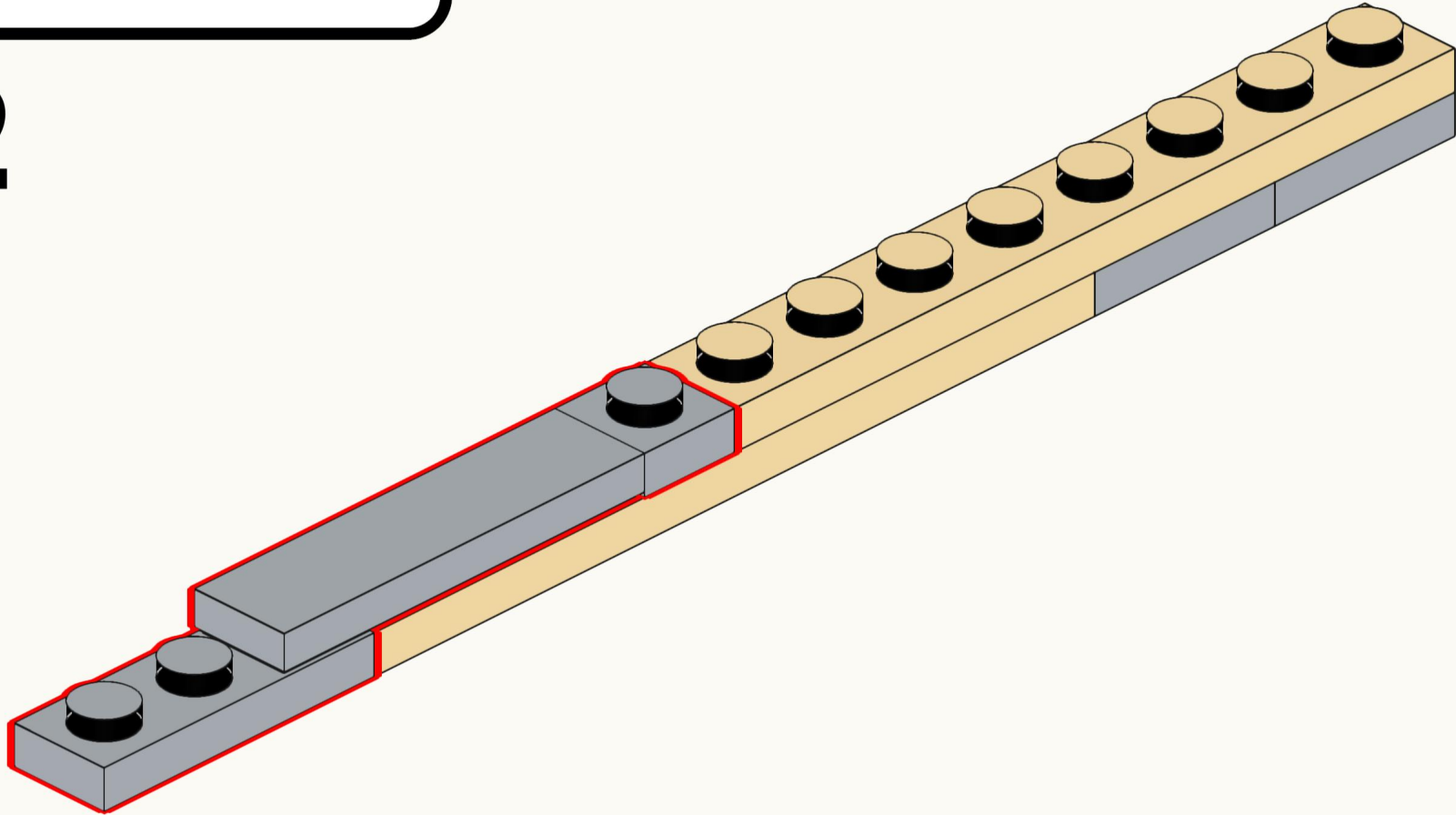

1x 1x 2x



43

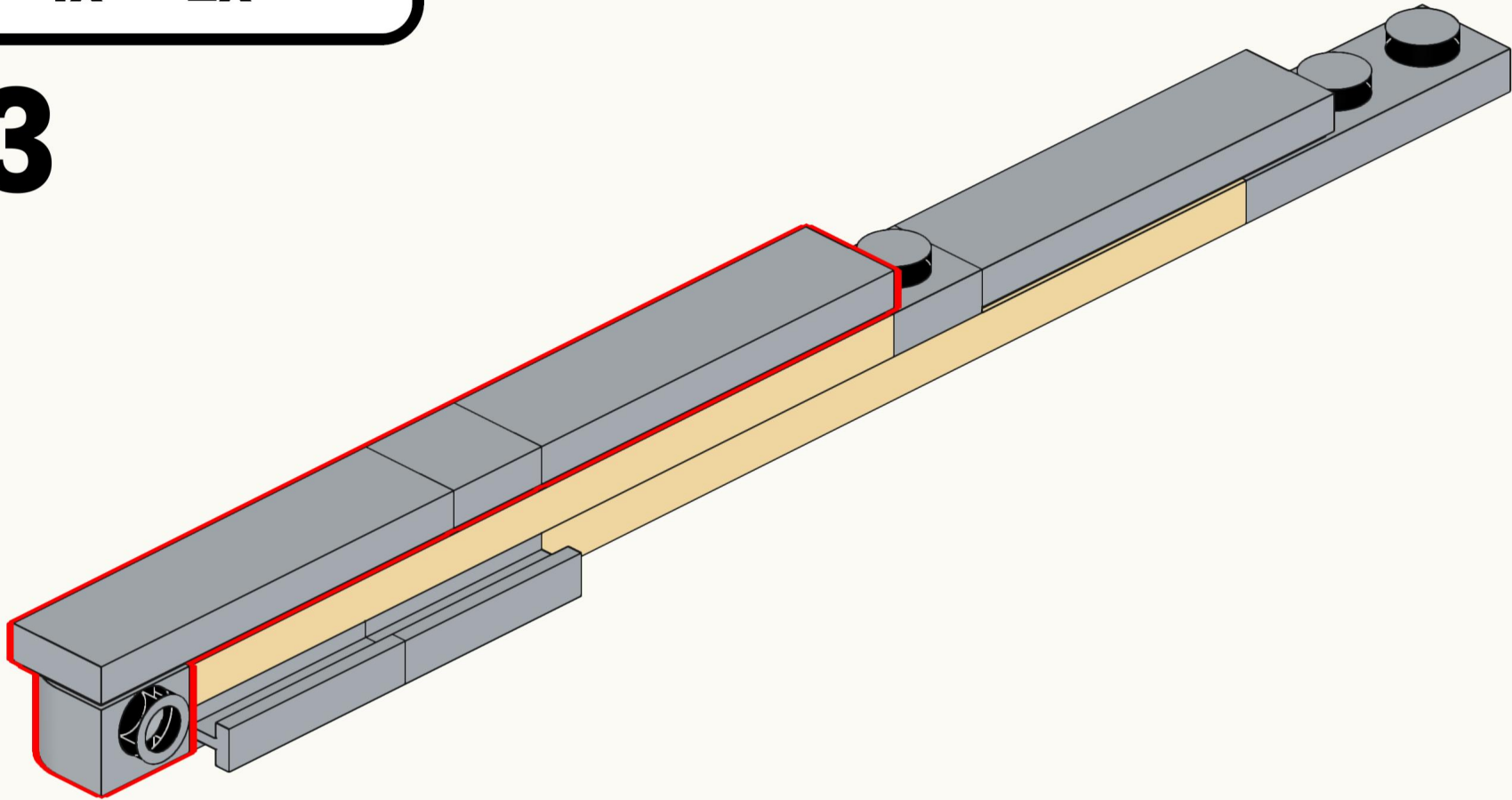

# 44

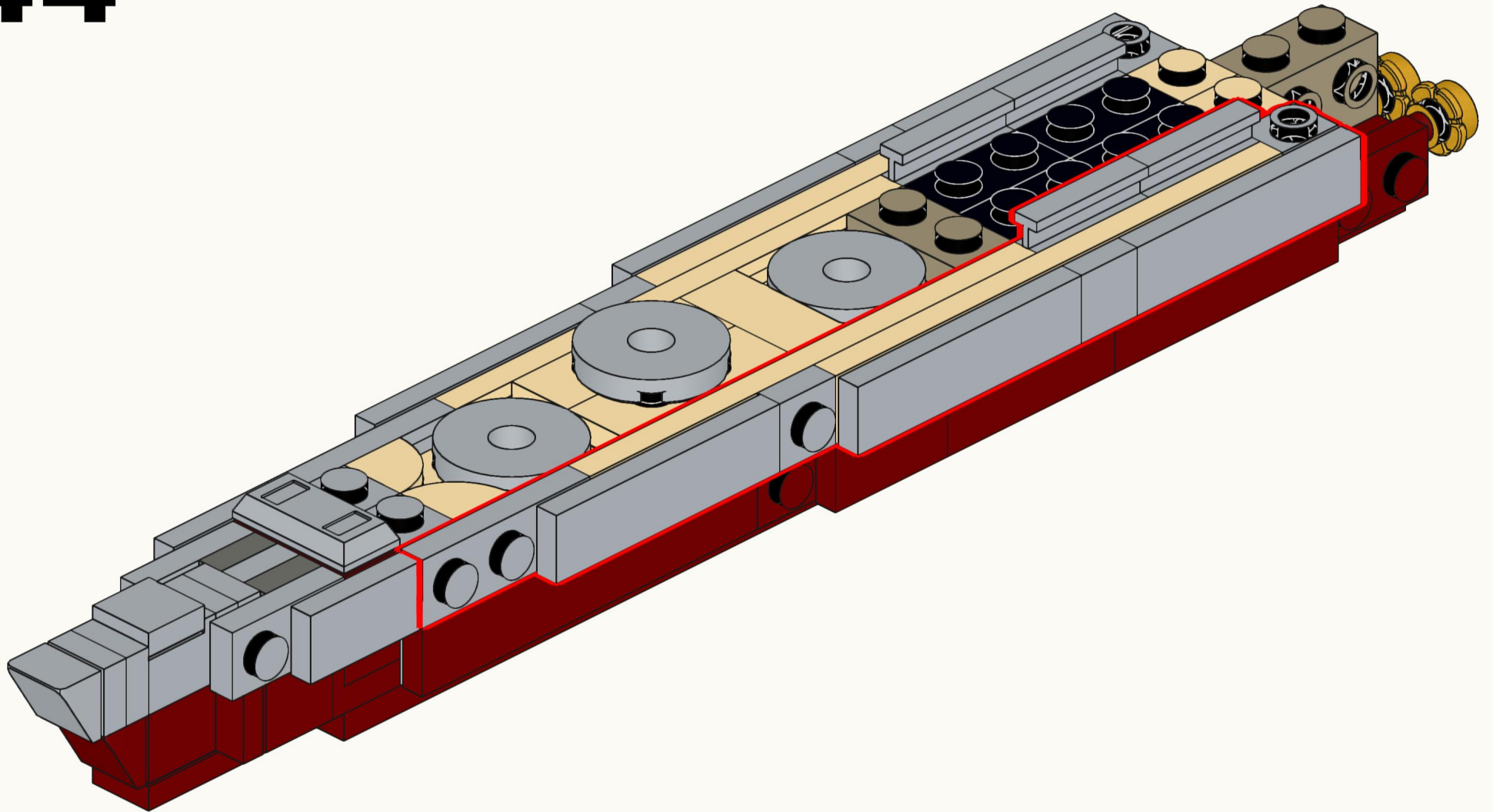

1x 1x 1x

45

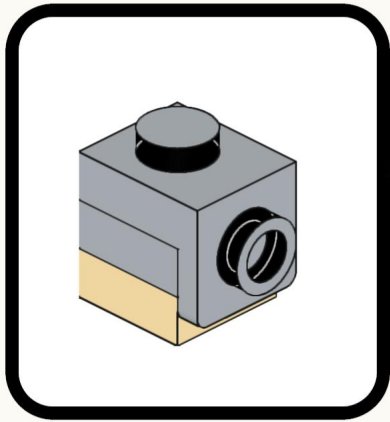
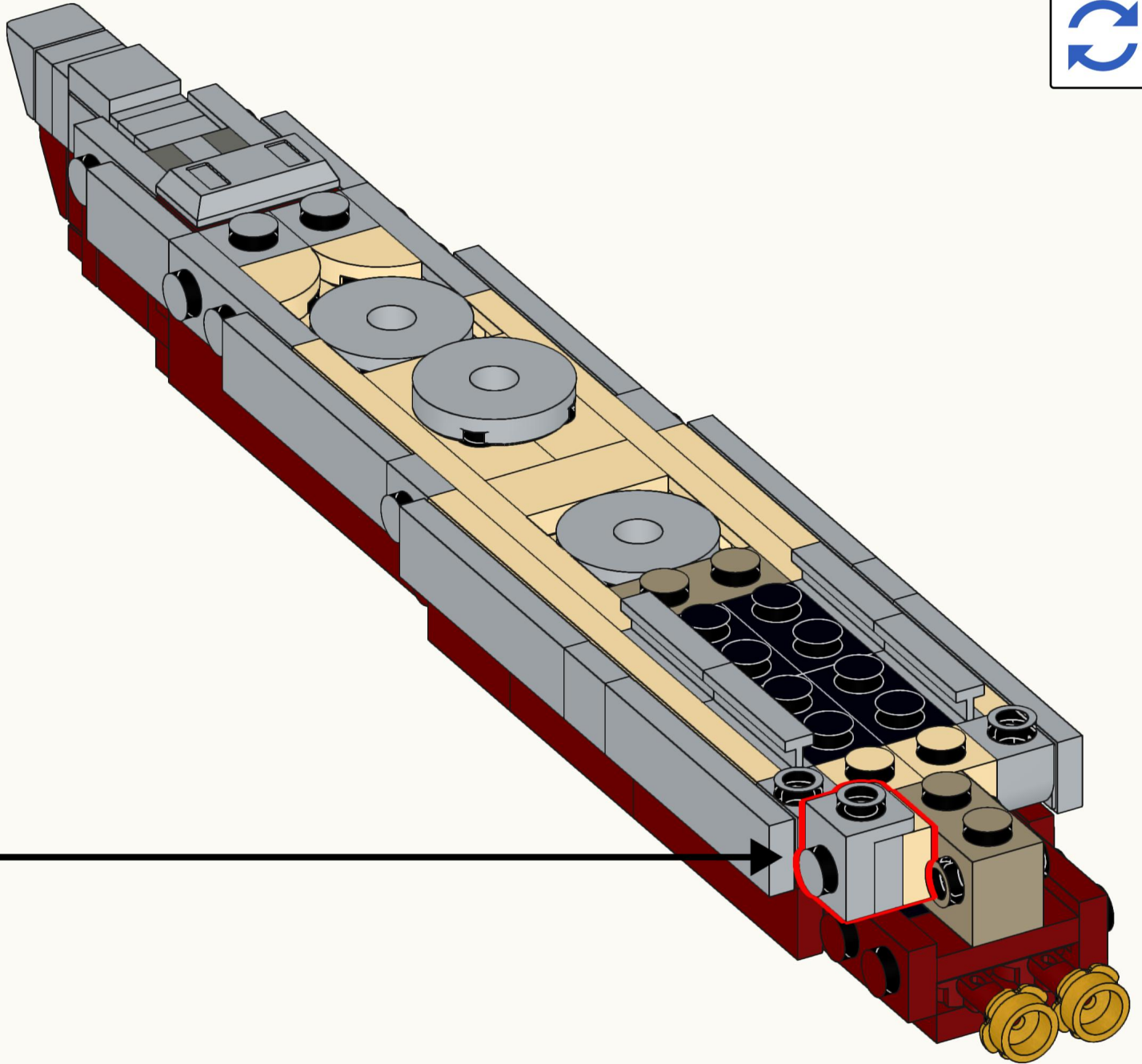

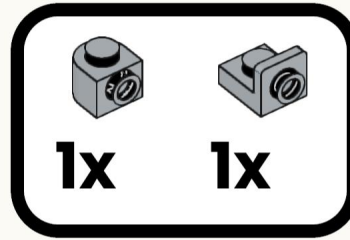
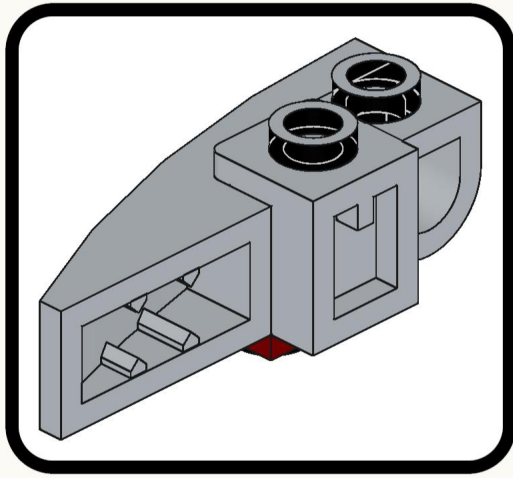

**47**

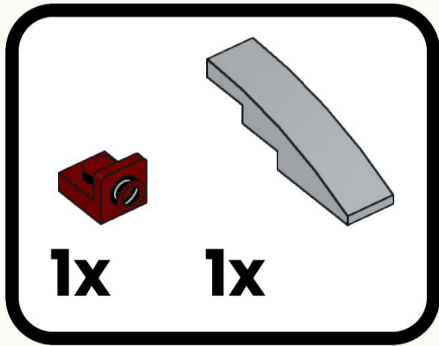

**46**

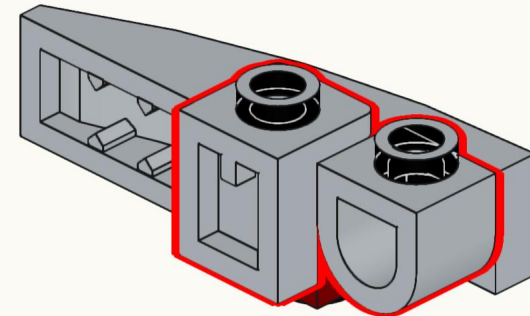
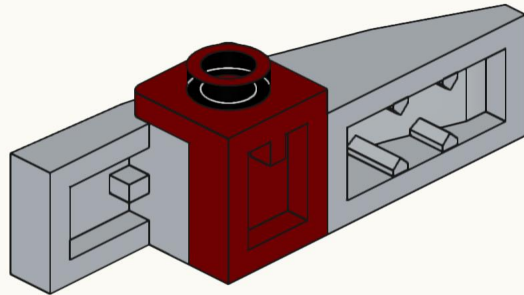

48

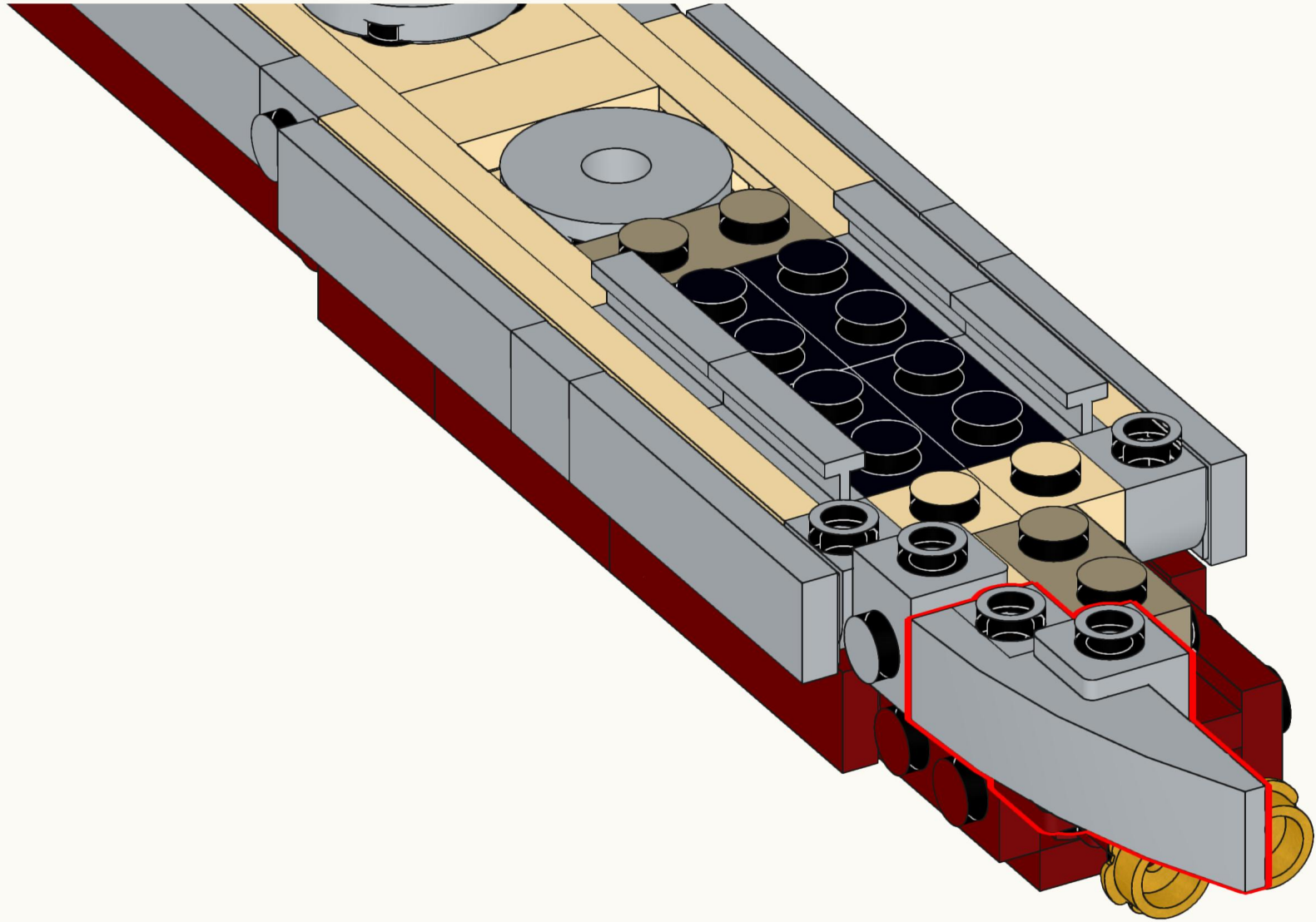

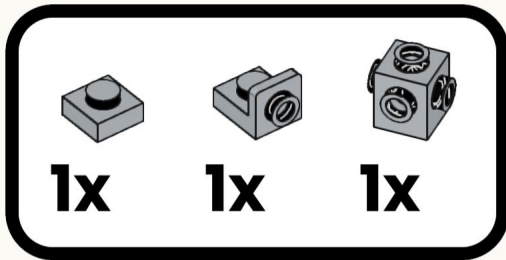
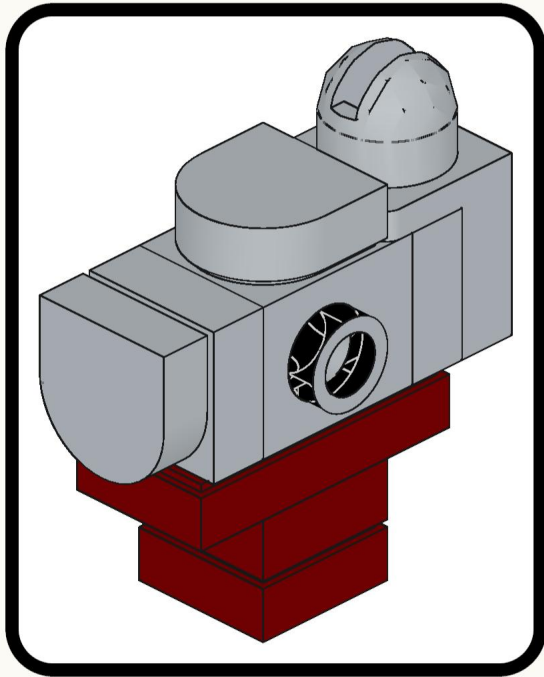



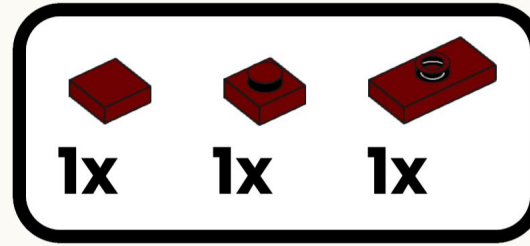
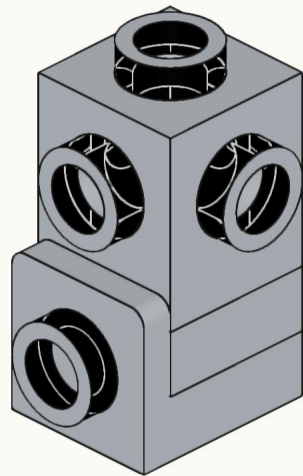

**49**

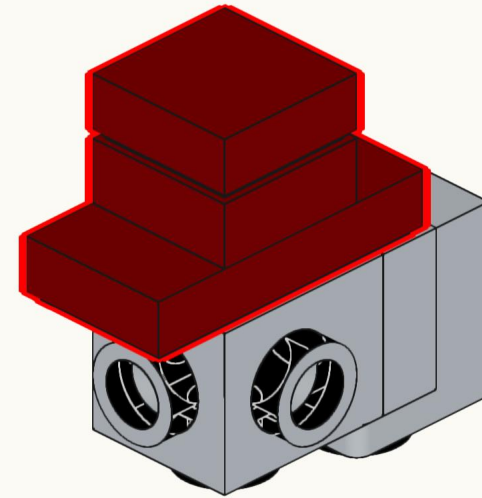

**50**



		
1x	2x	1x



# 51

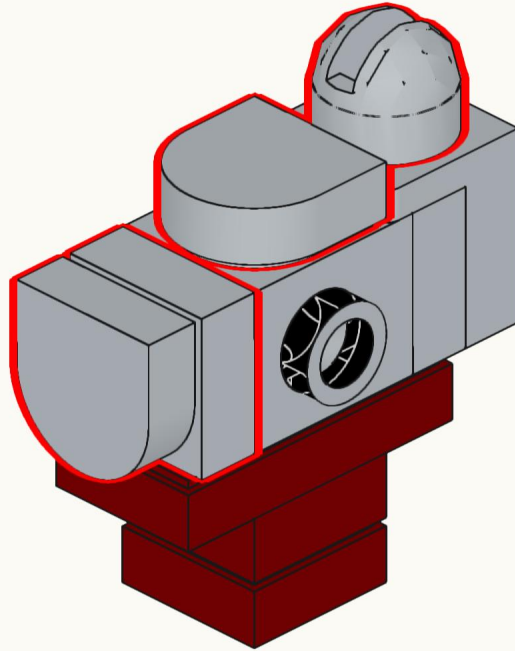

# 52

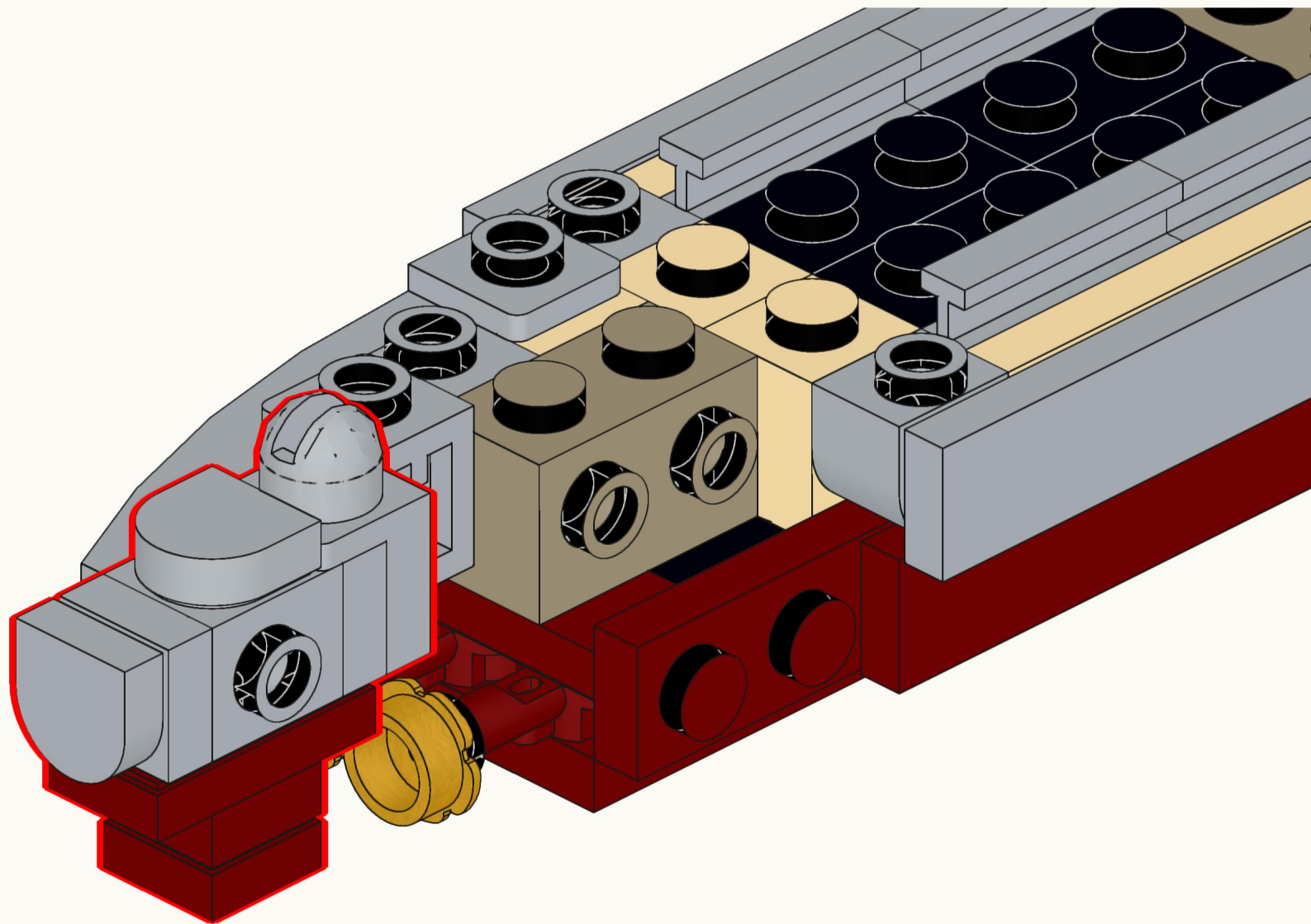

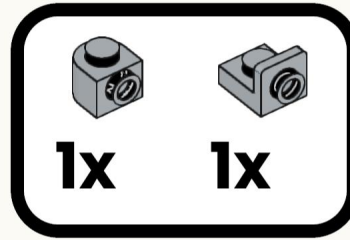
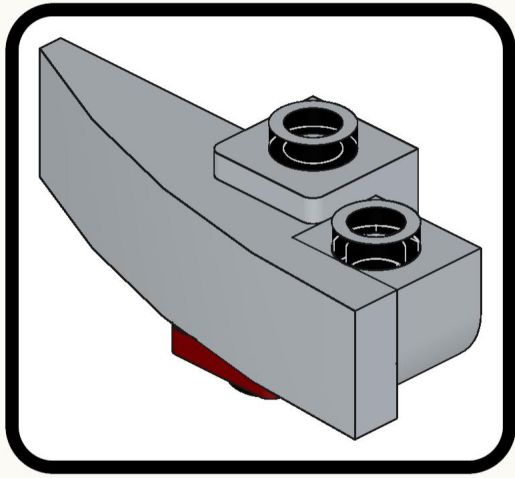

**54**

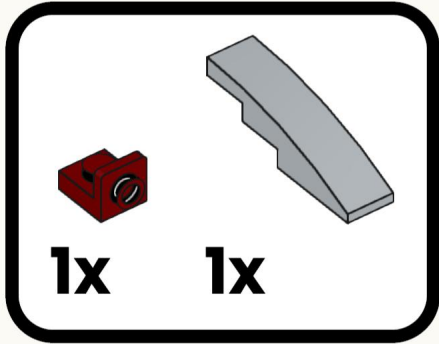

**53**

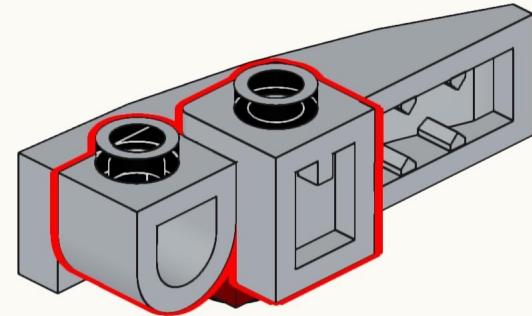
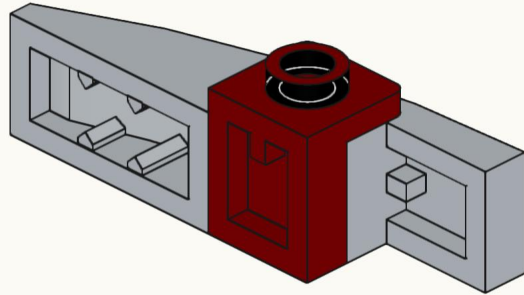

55

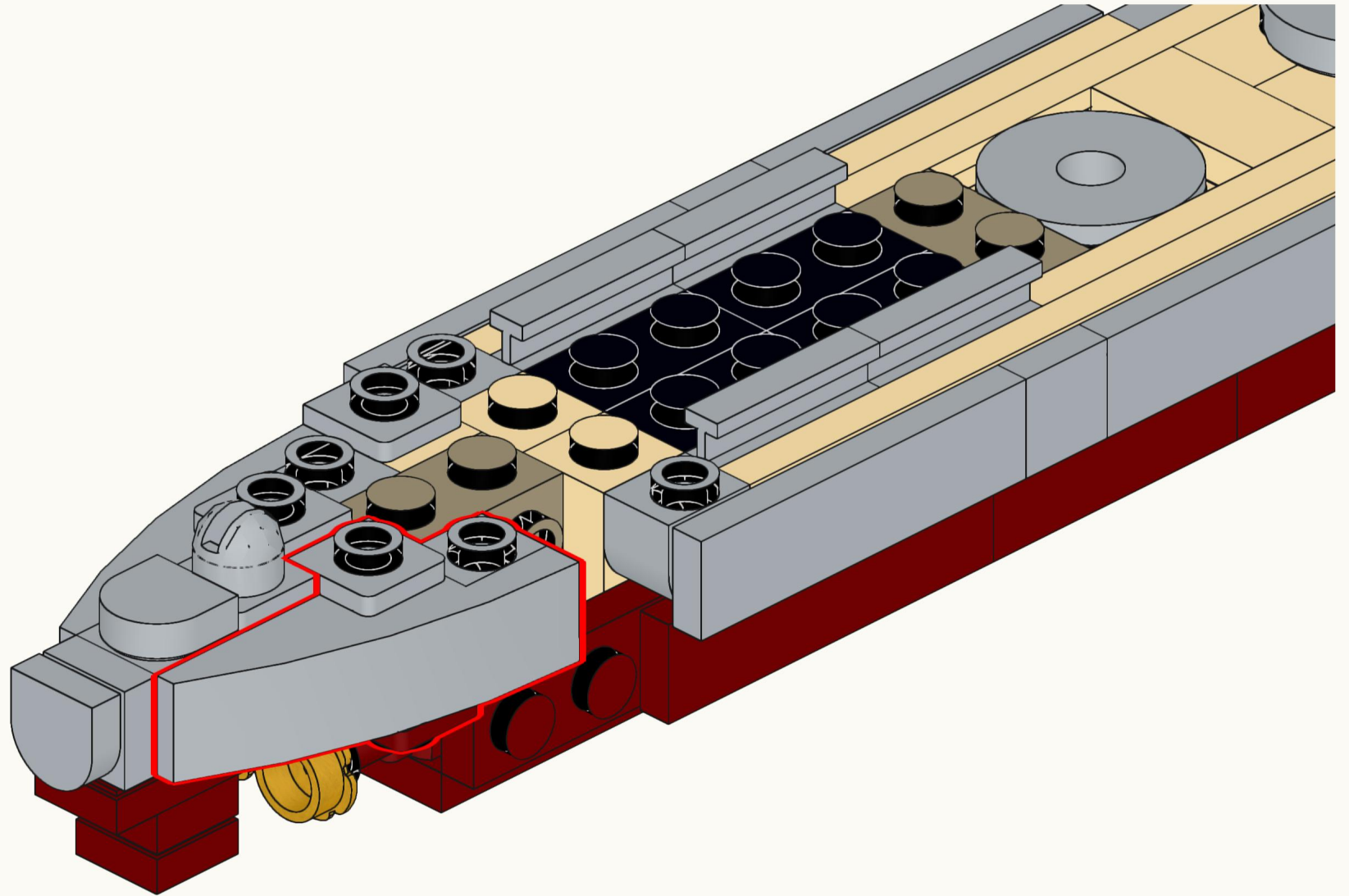

1x 1x 1x

56

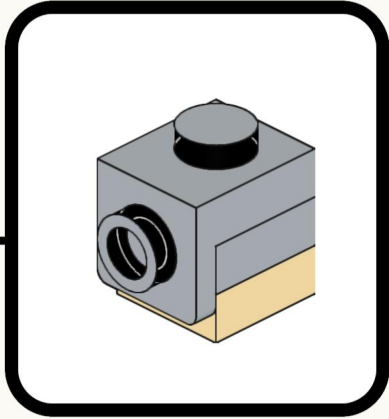
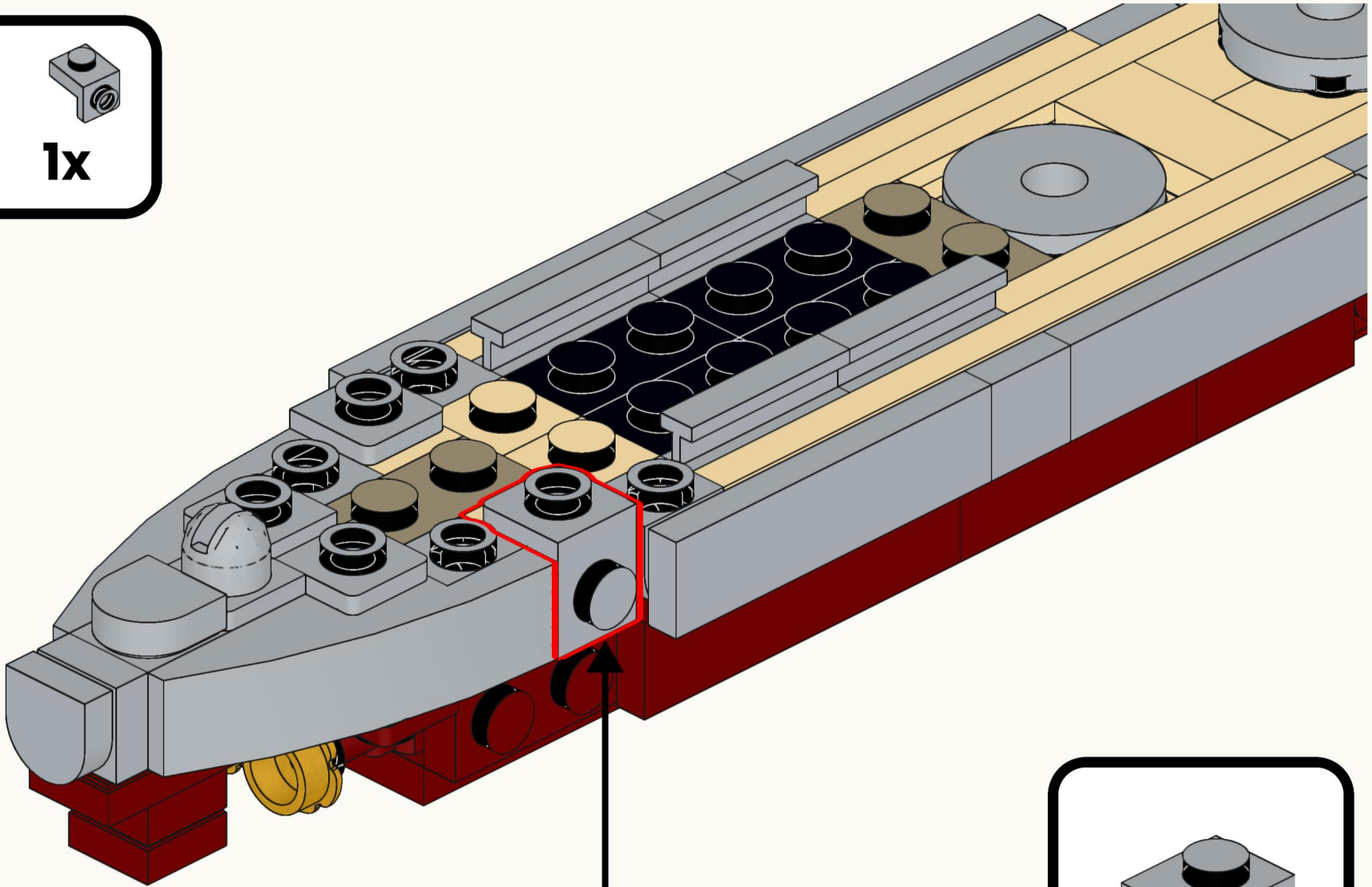



**57**

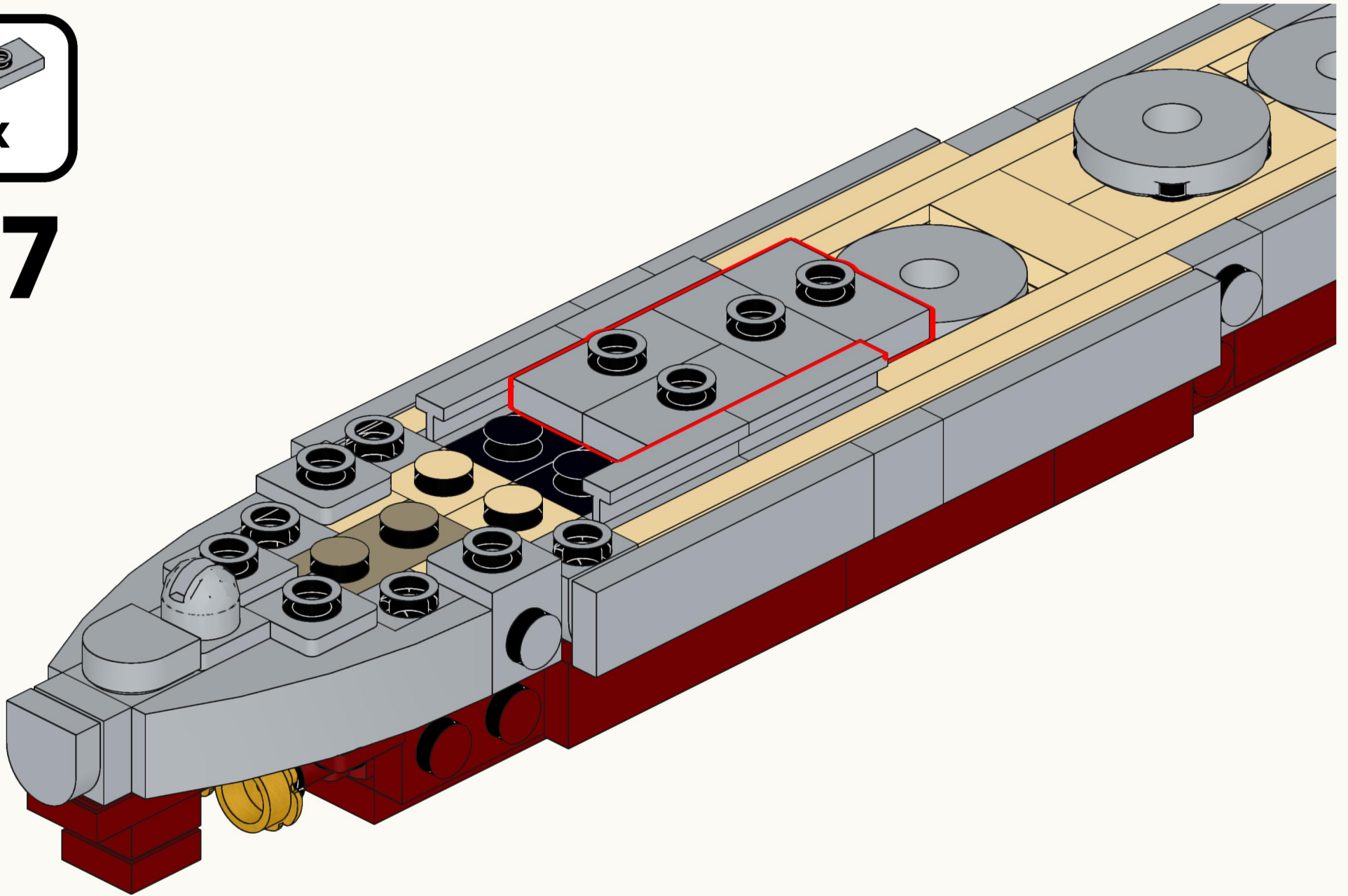

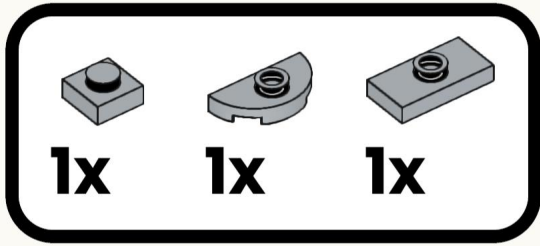

58

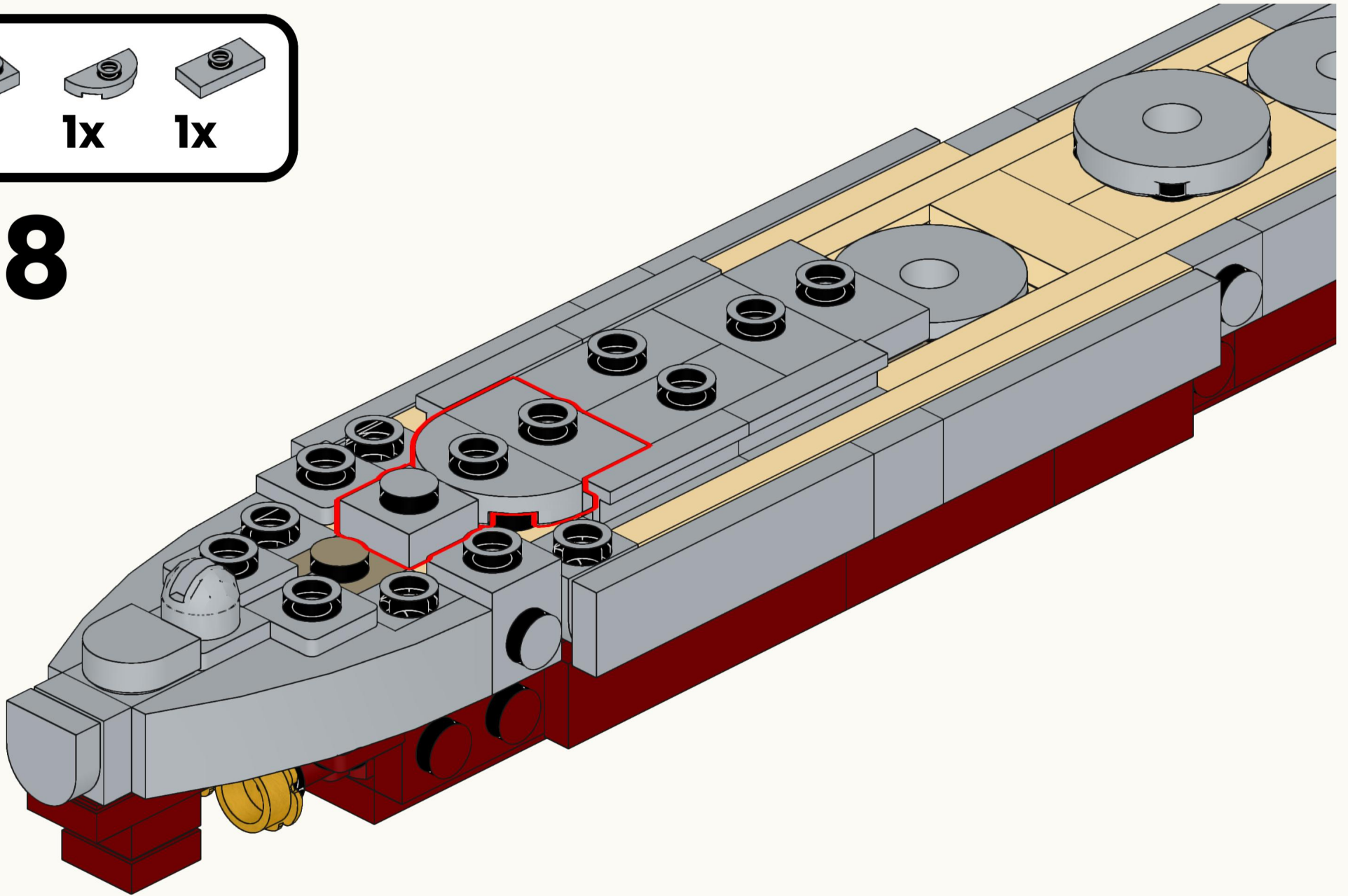



**59**

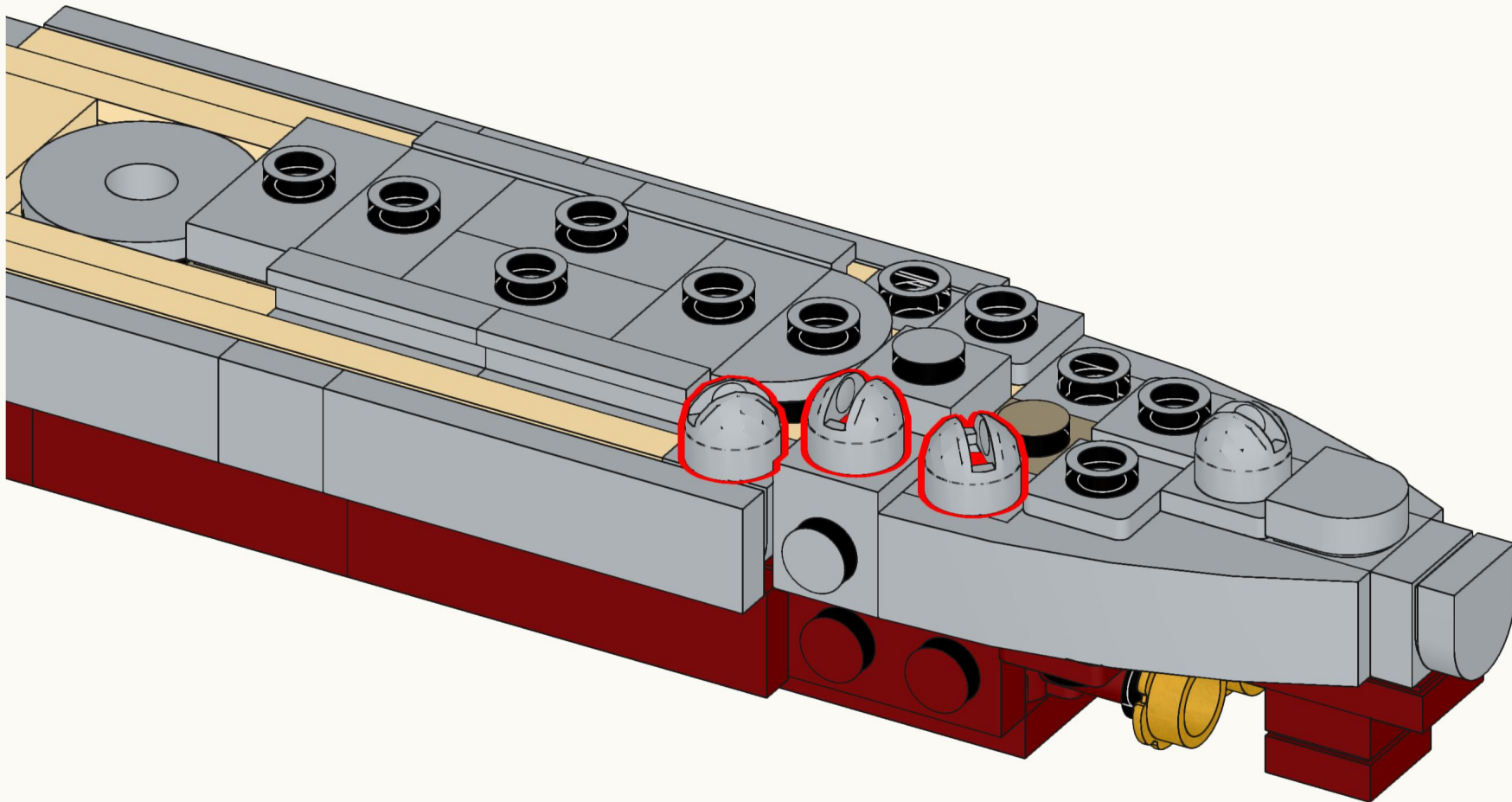



60

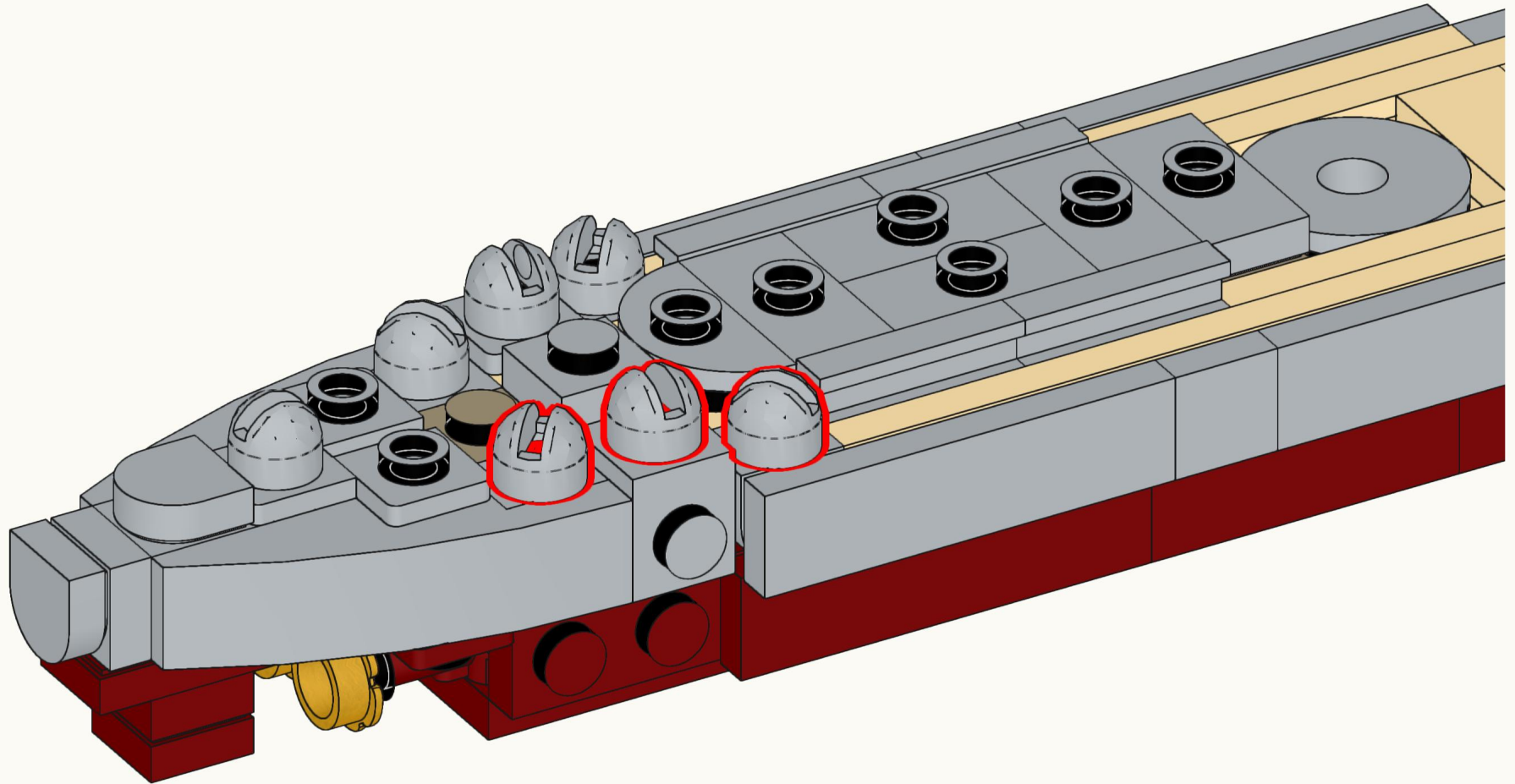

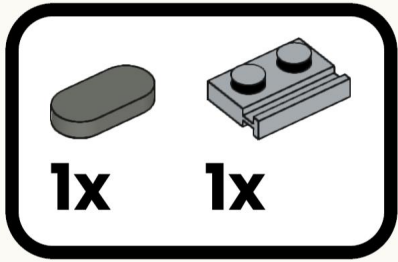

61

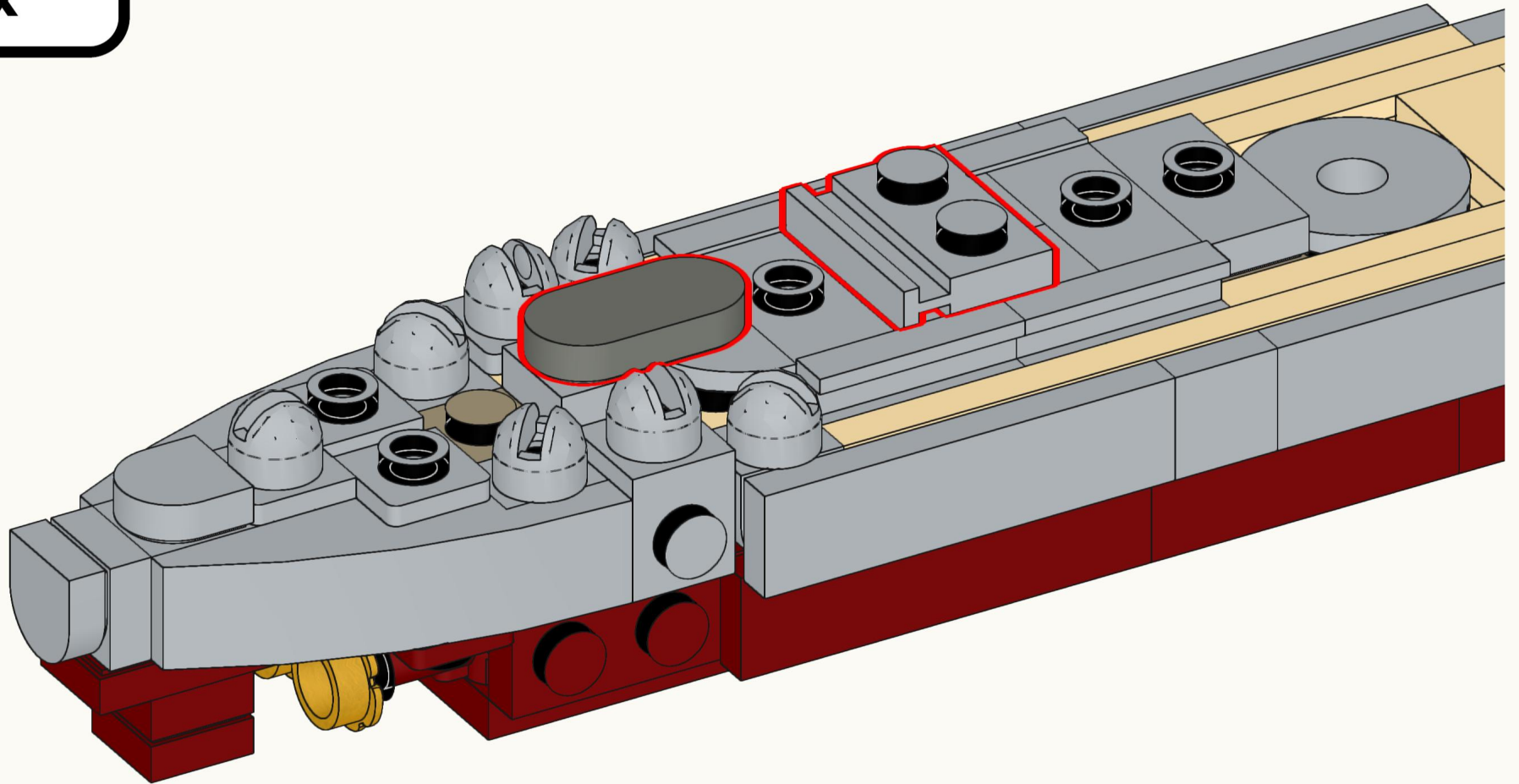

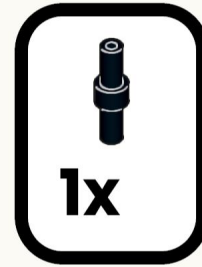
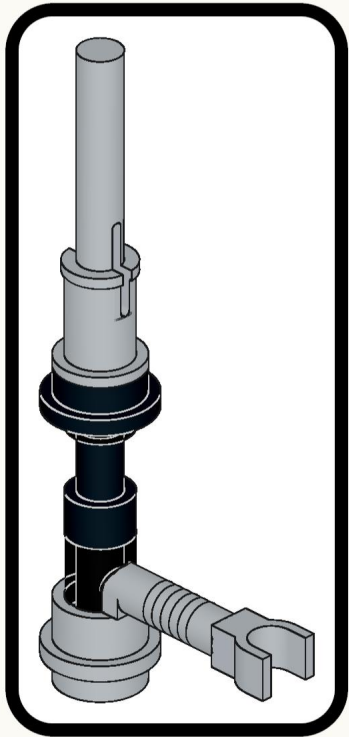

**63**

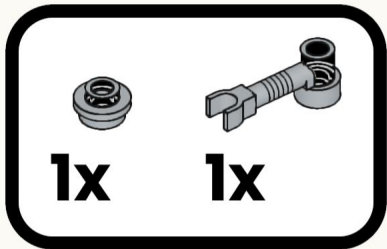

**62**

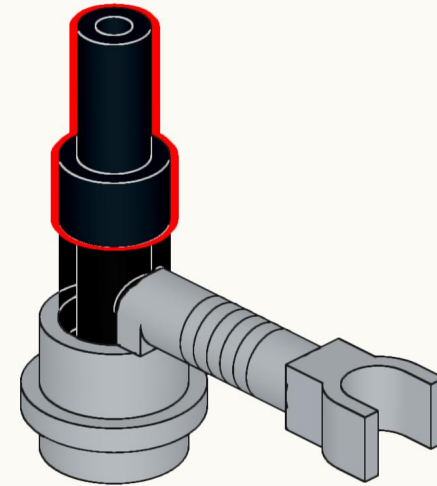
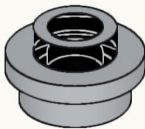
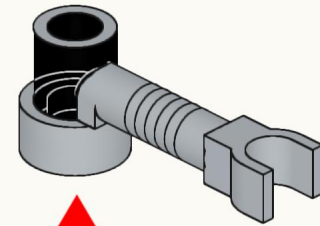

**65**

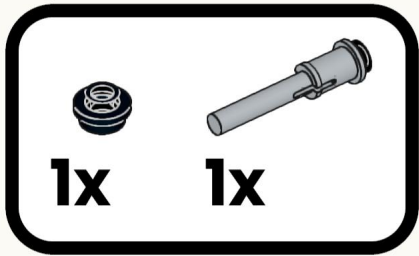
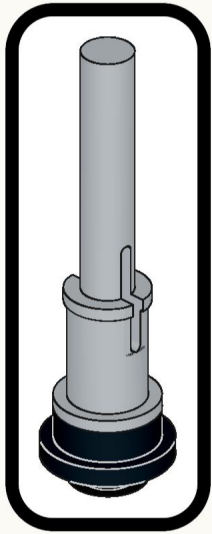

**64**

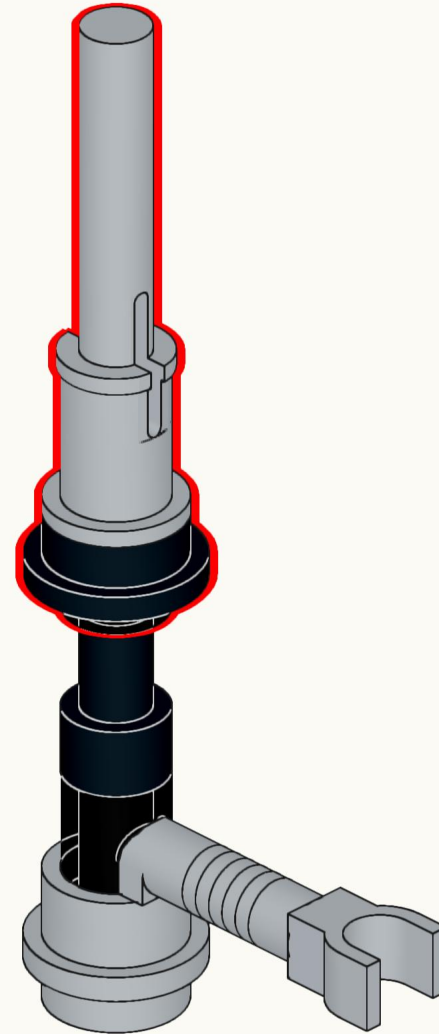
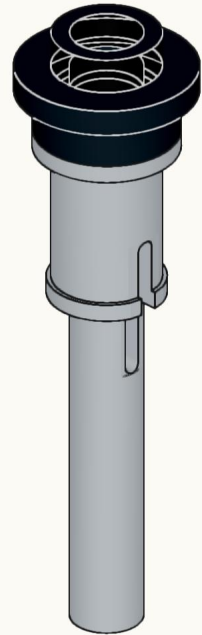

66

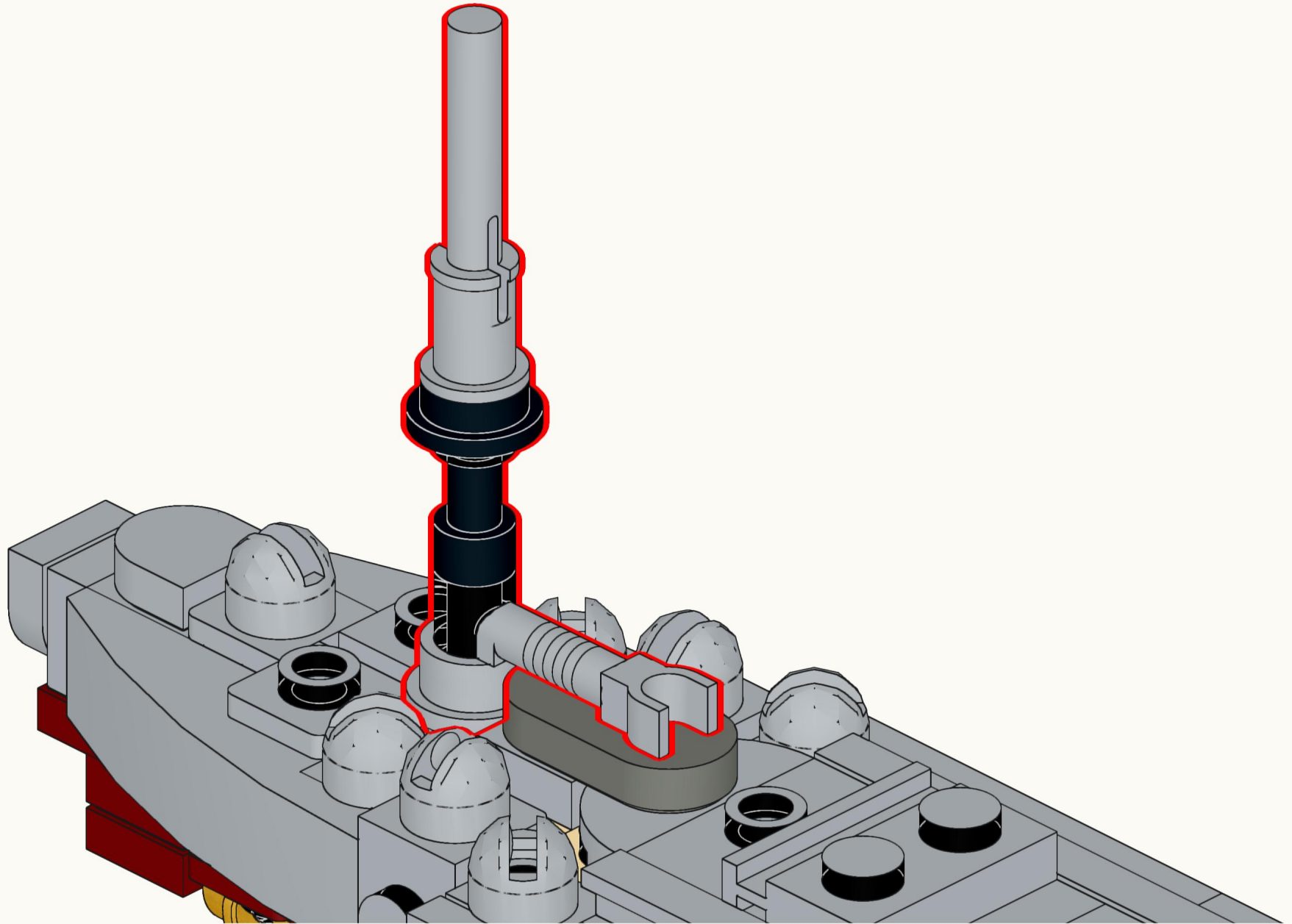

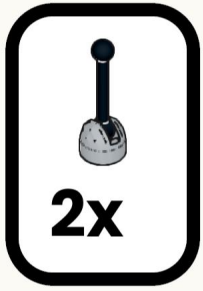

67

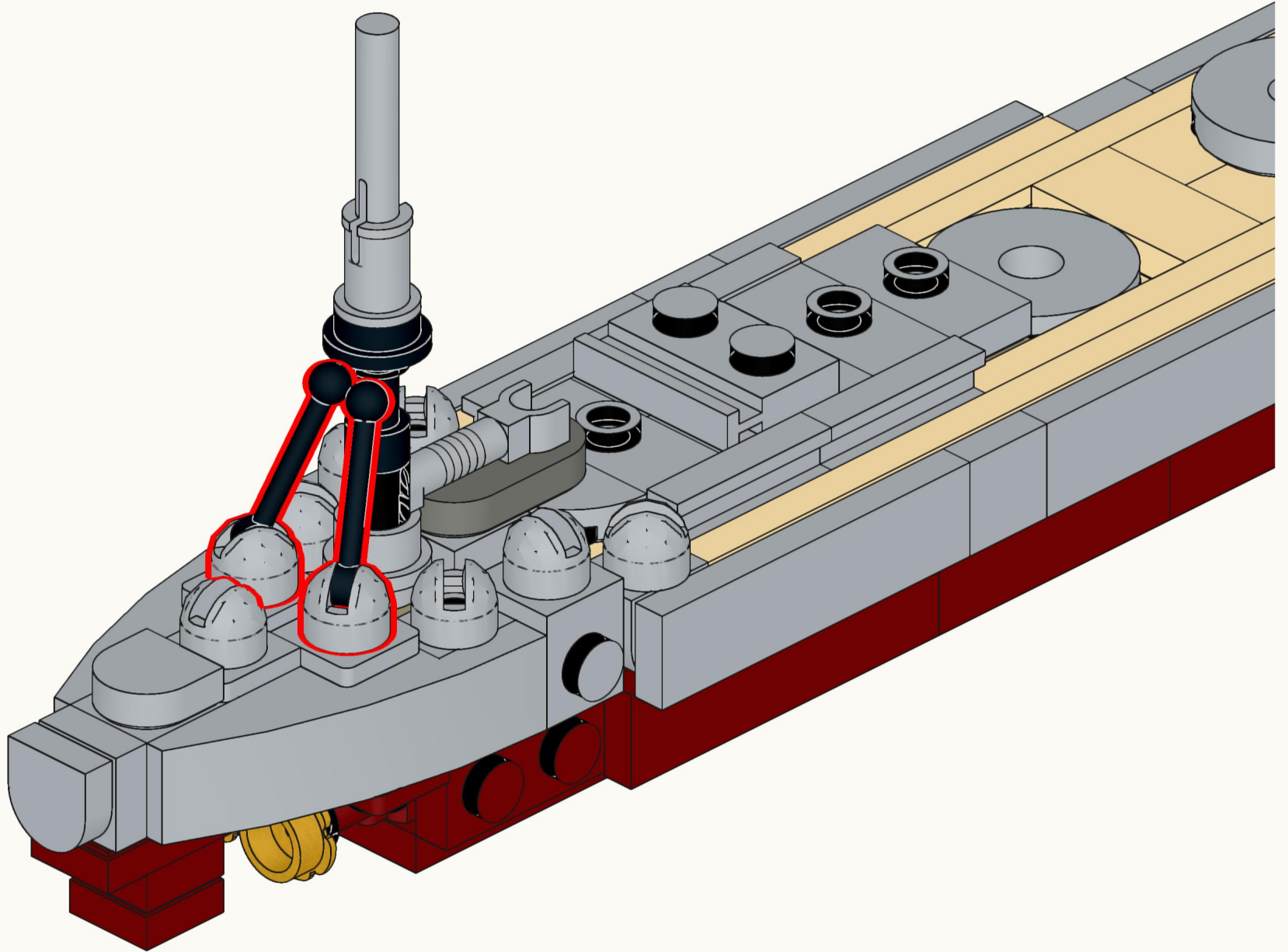

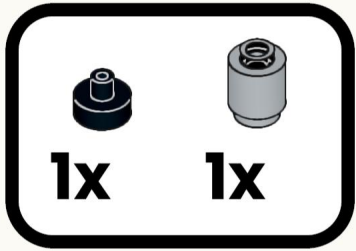

68

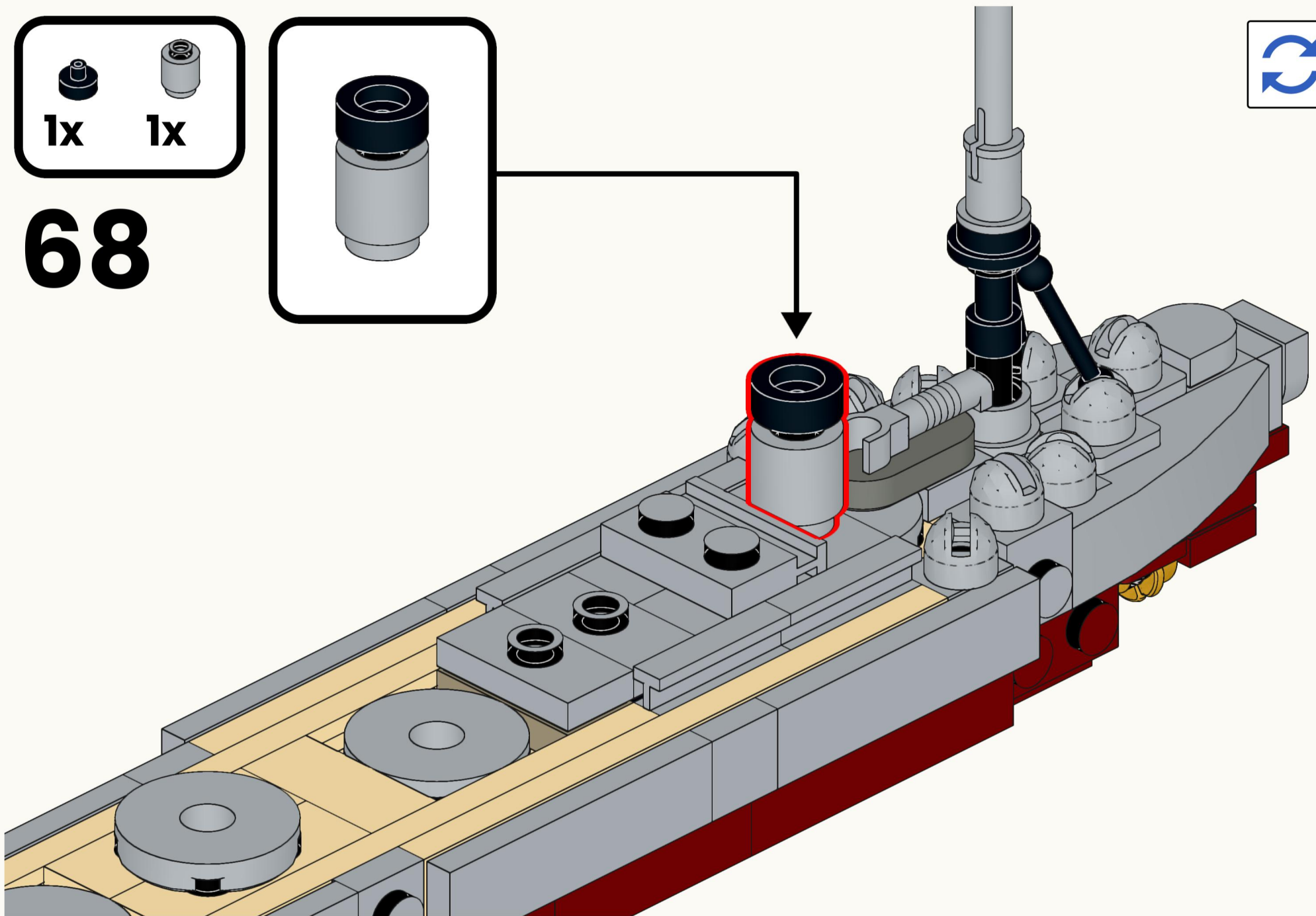
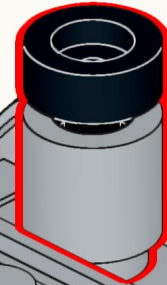
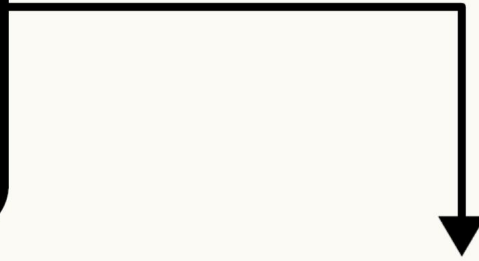

1x 1x

69

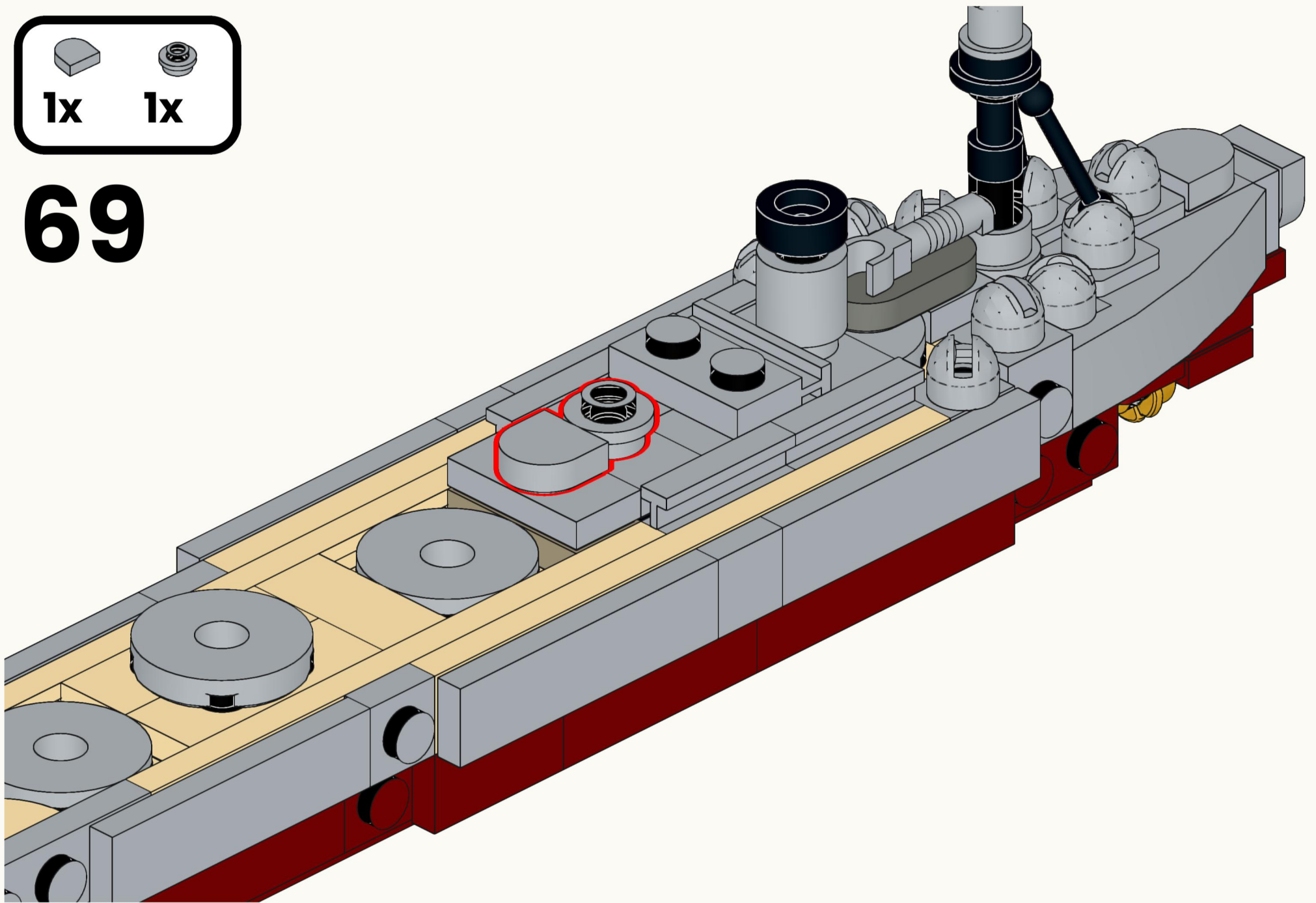

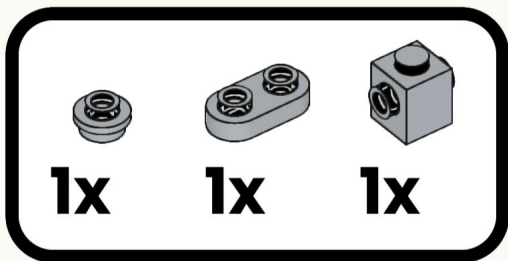
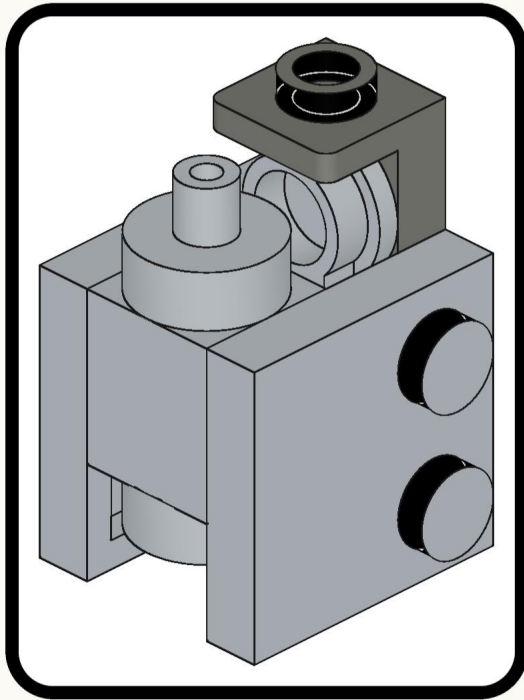

**70**

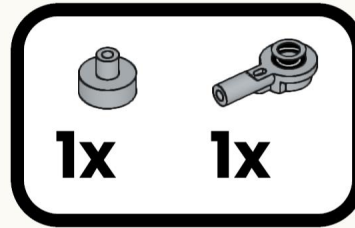
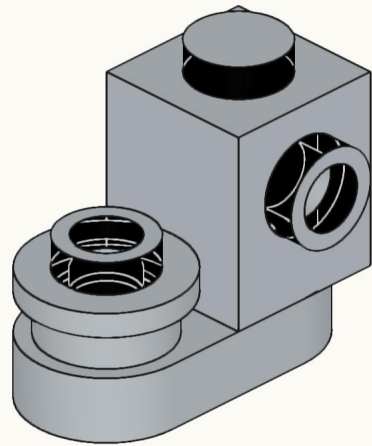

**71**

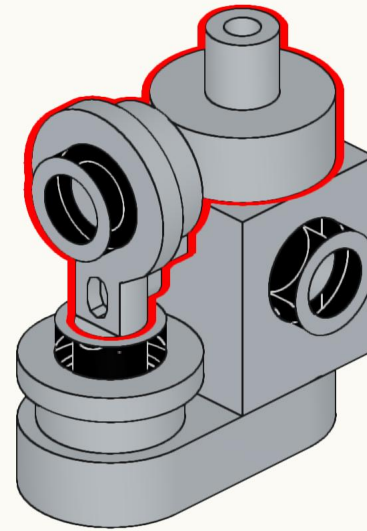

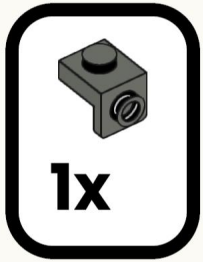

72

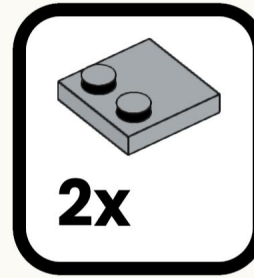
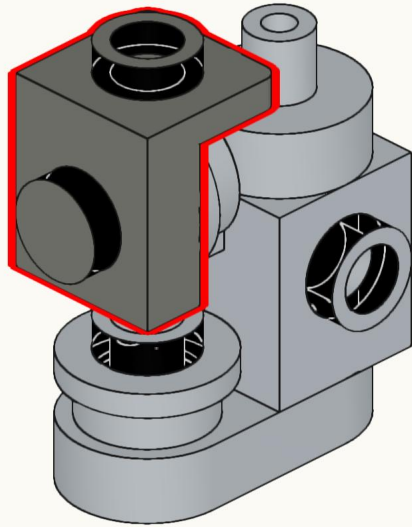

73

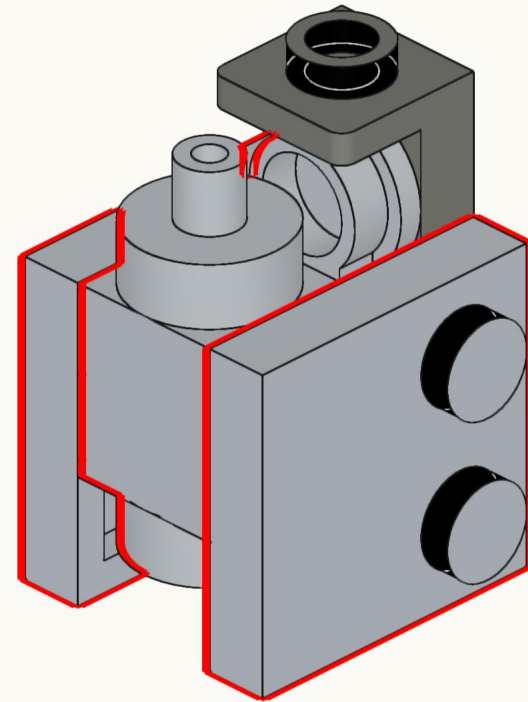

74

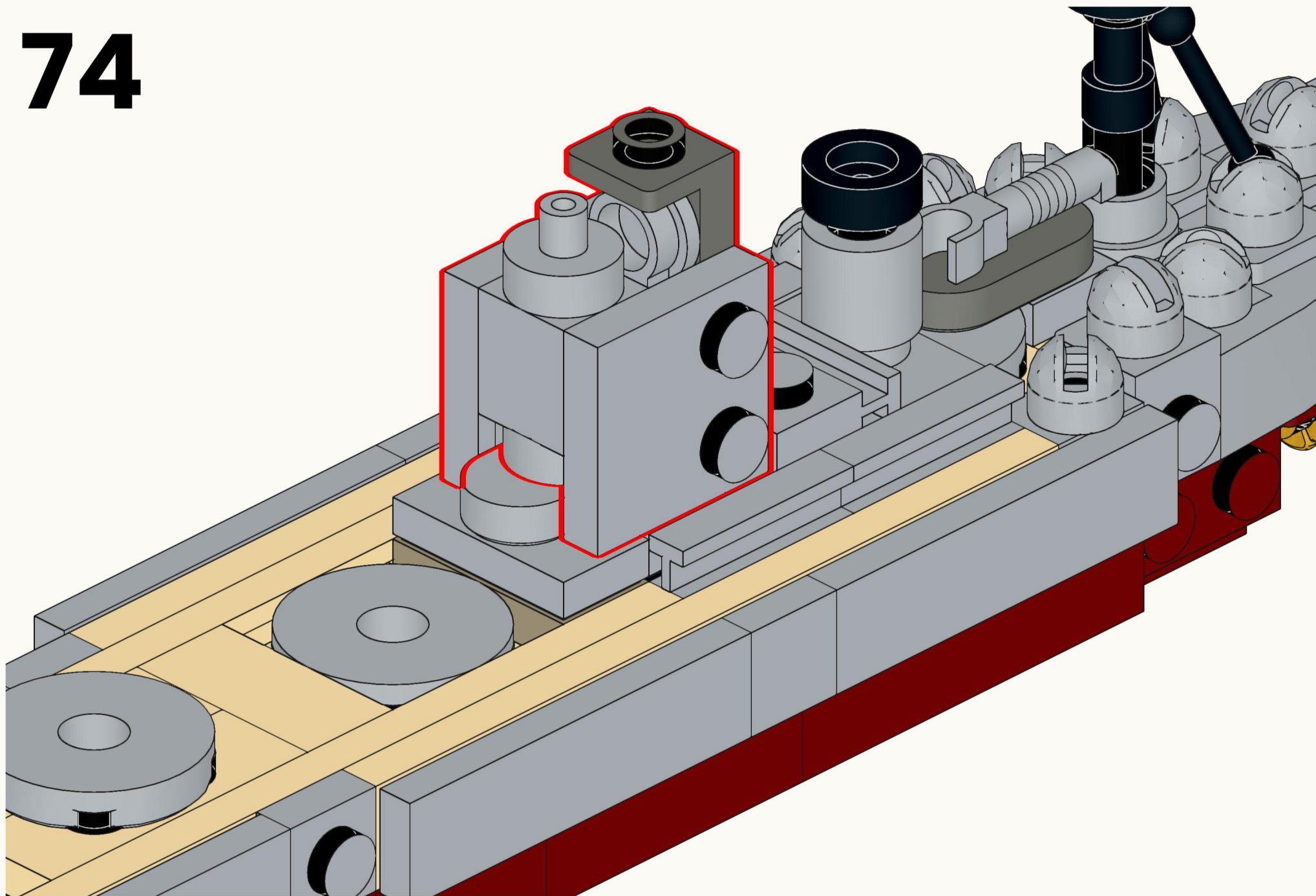



75

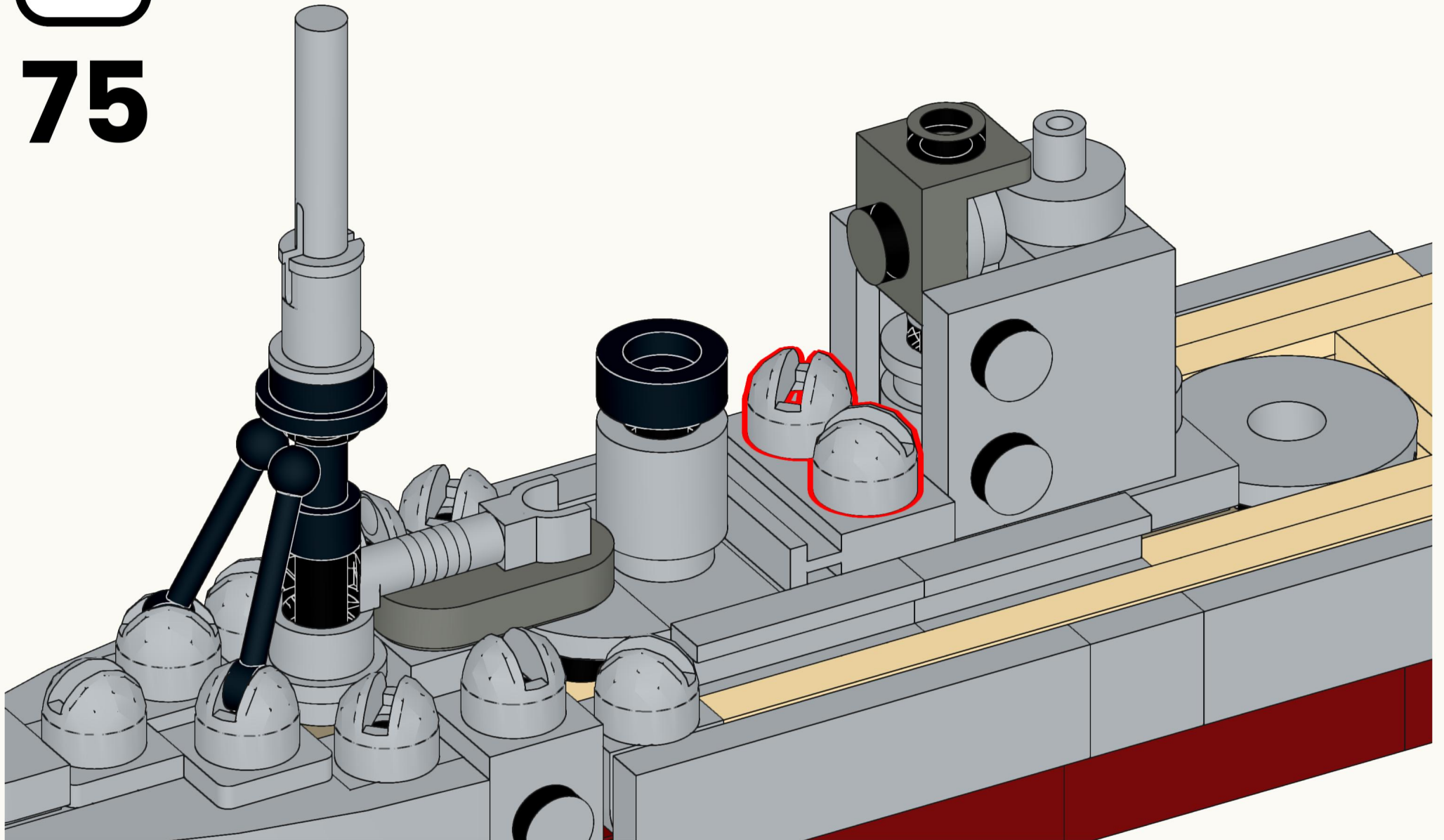

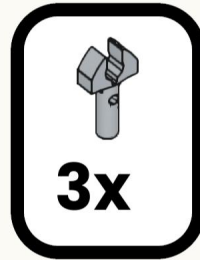
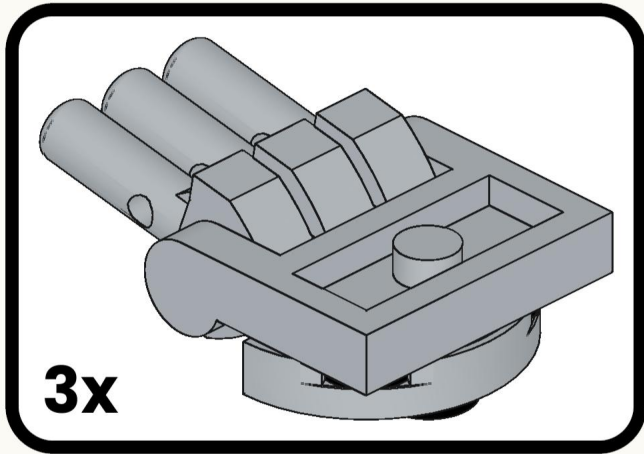

**77**

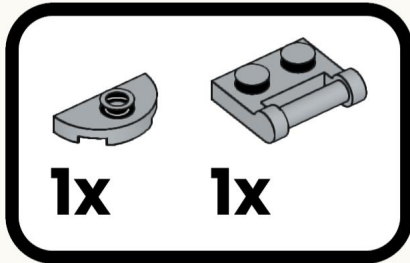

**76**

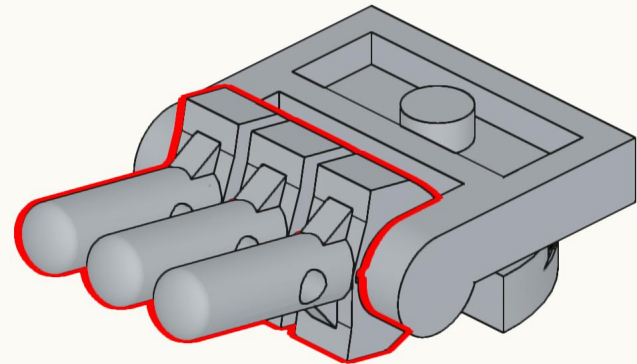
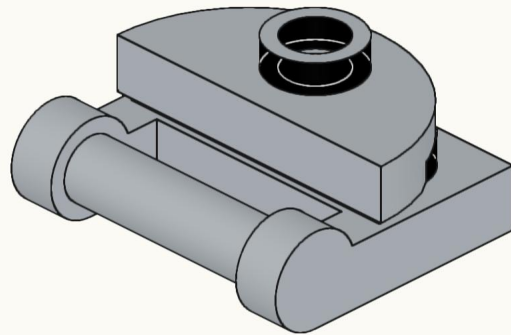

# 78



All three triple turrets were positioned forward of the bridge and designated A, B and C.

Turret B was superfiring over A, and C was sitting on the forecastle deck behind B.

This meant C turret could not fire directly forward or aft, only across a wide arc to each side.

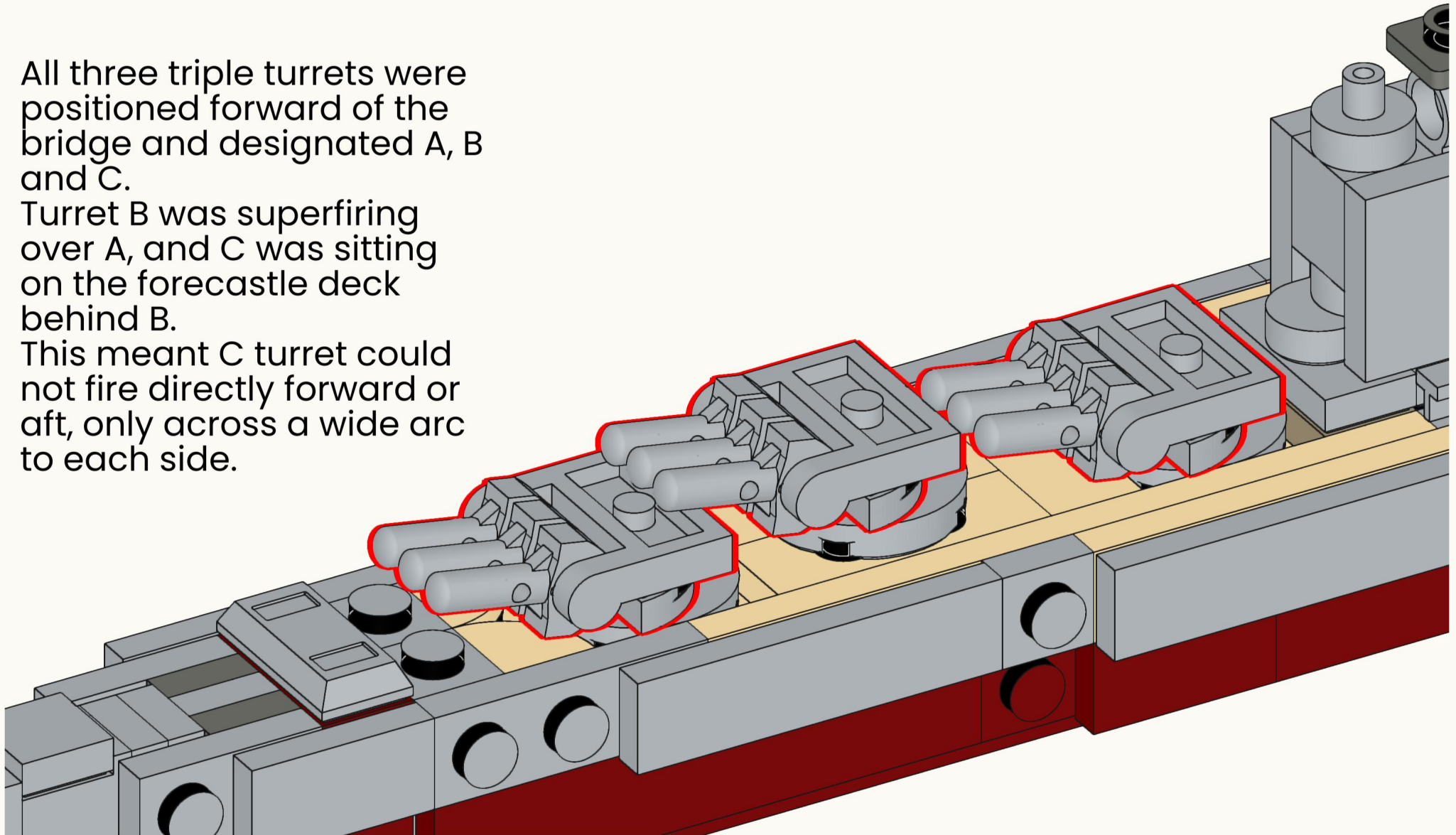

# 79

The all-forward arrangement was radical for its time and directly influenced subsequent warship design.

A similar all-forward turret layout was later adopted by the French in both the Dunkerque and Richelieu classes of battleships.

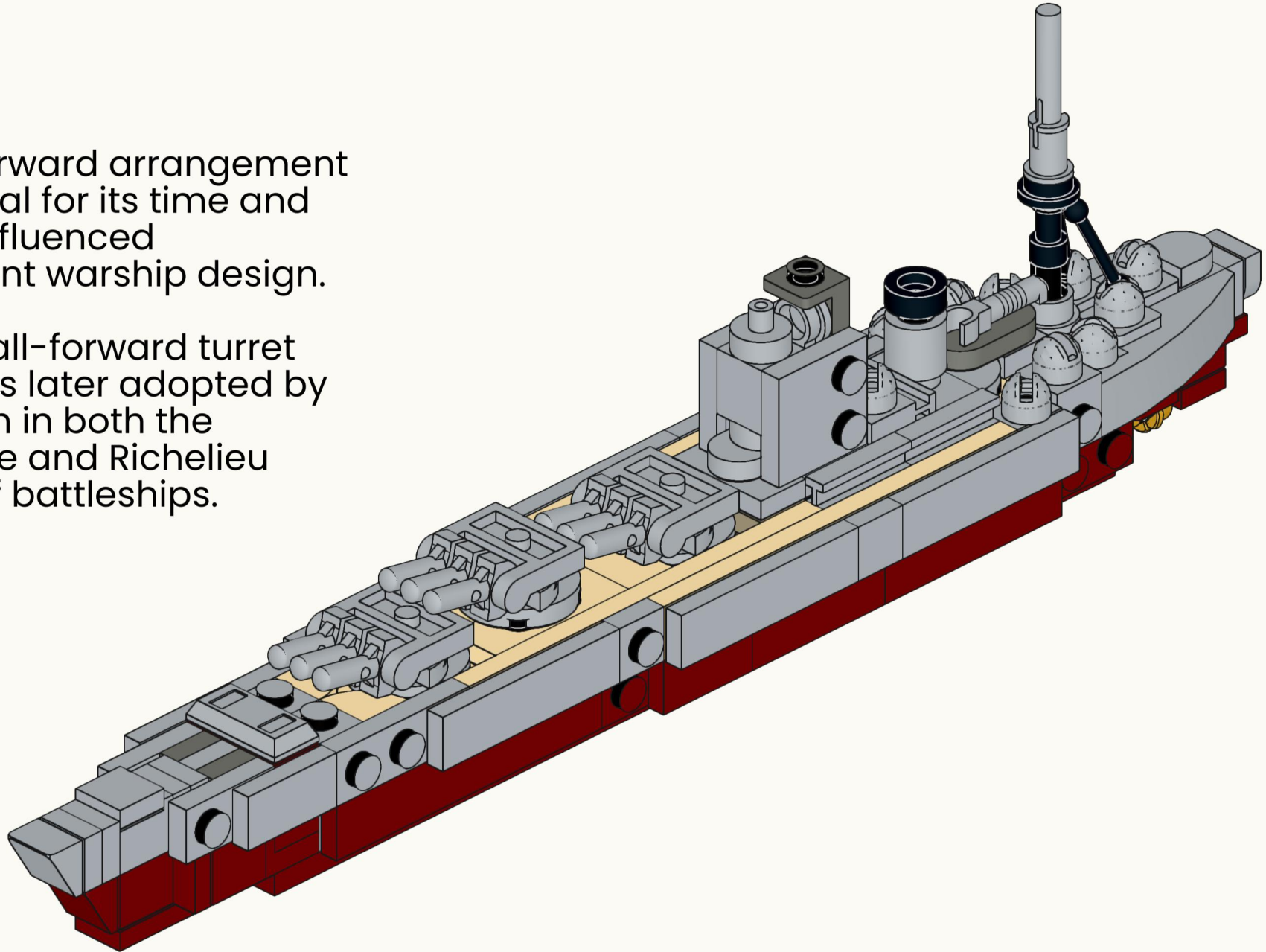

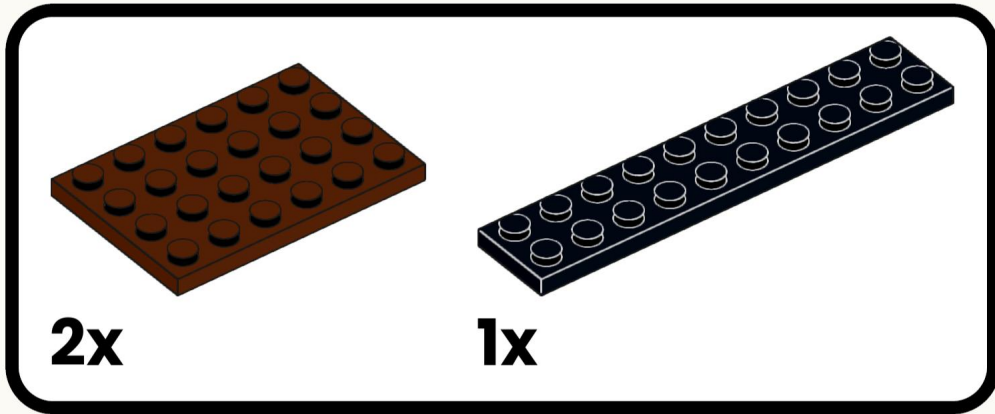
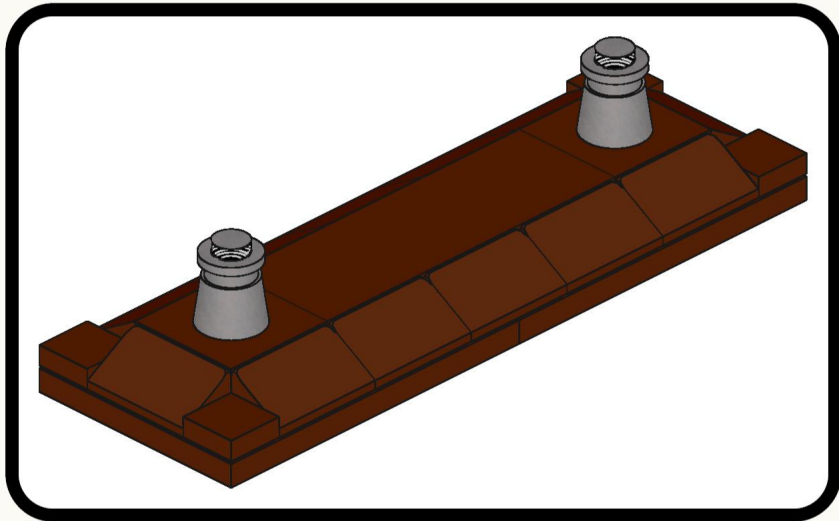

80

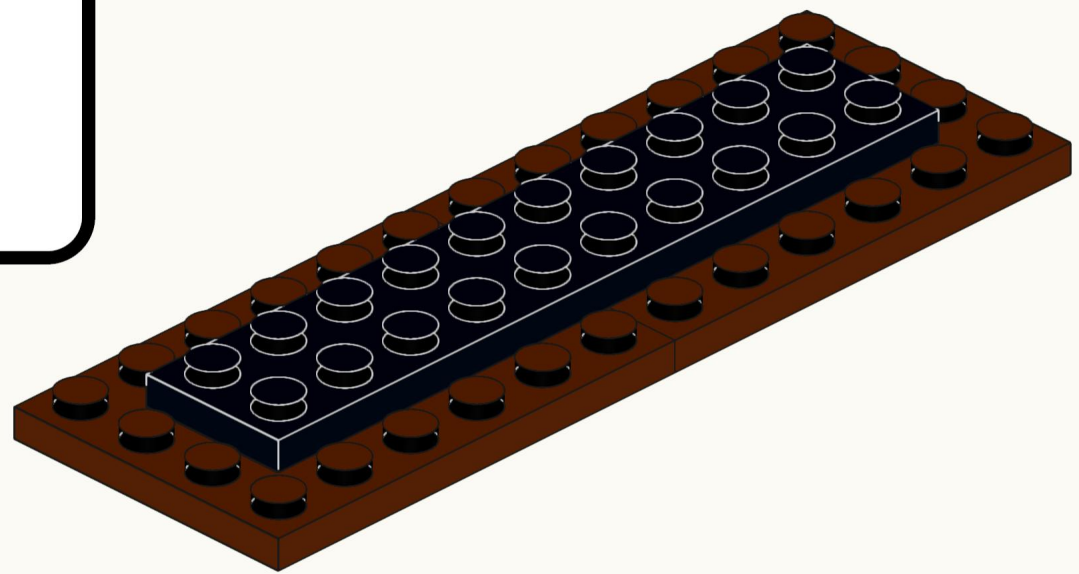



81

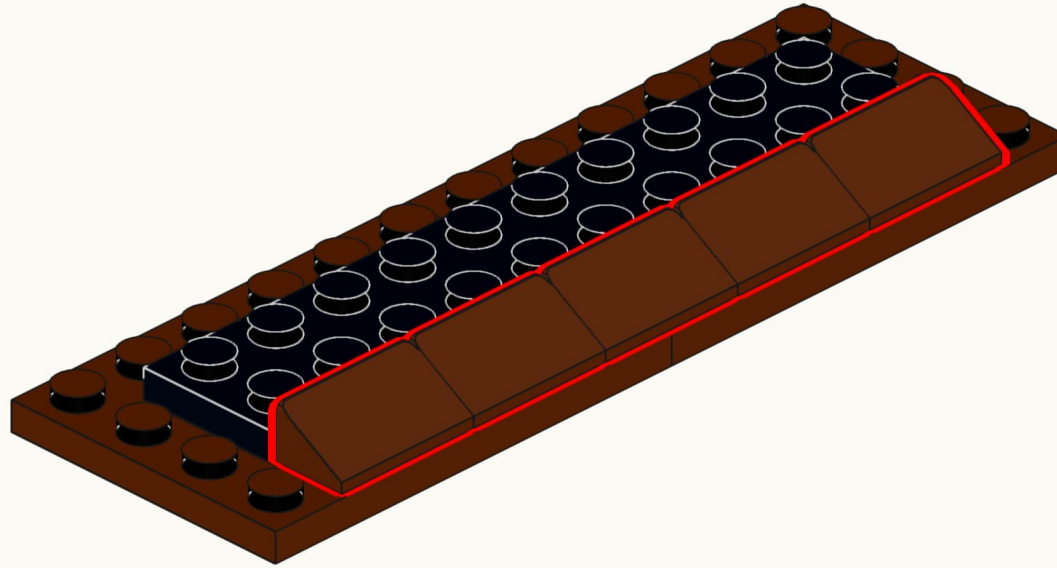

82

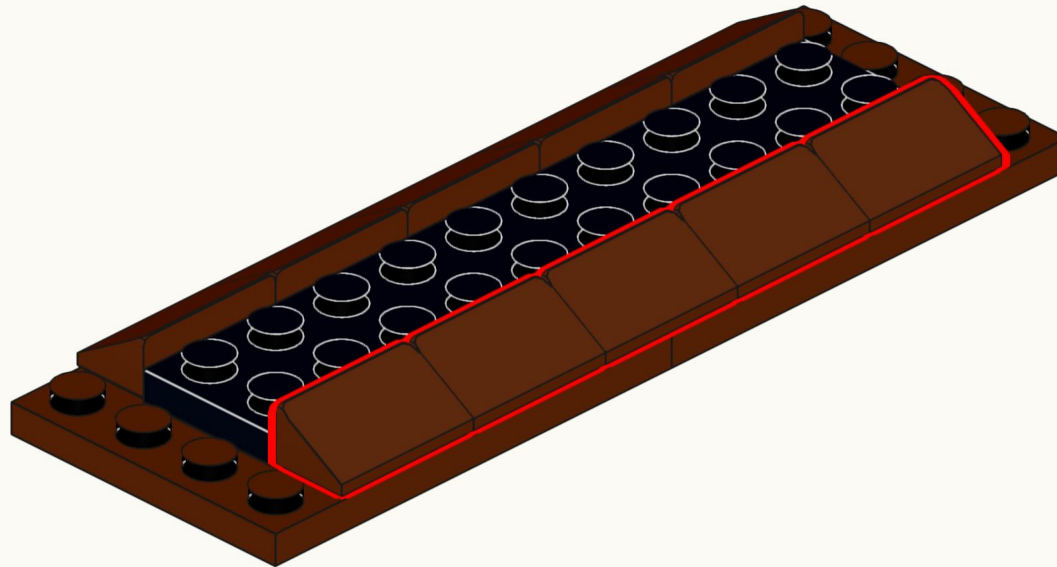

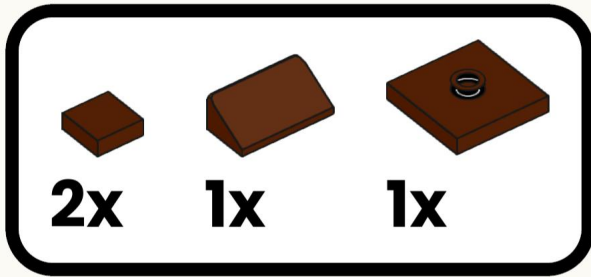

83

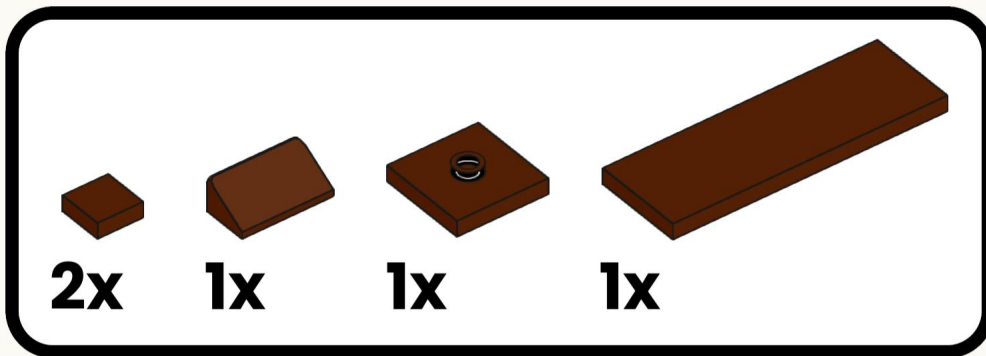
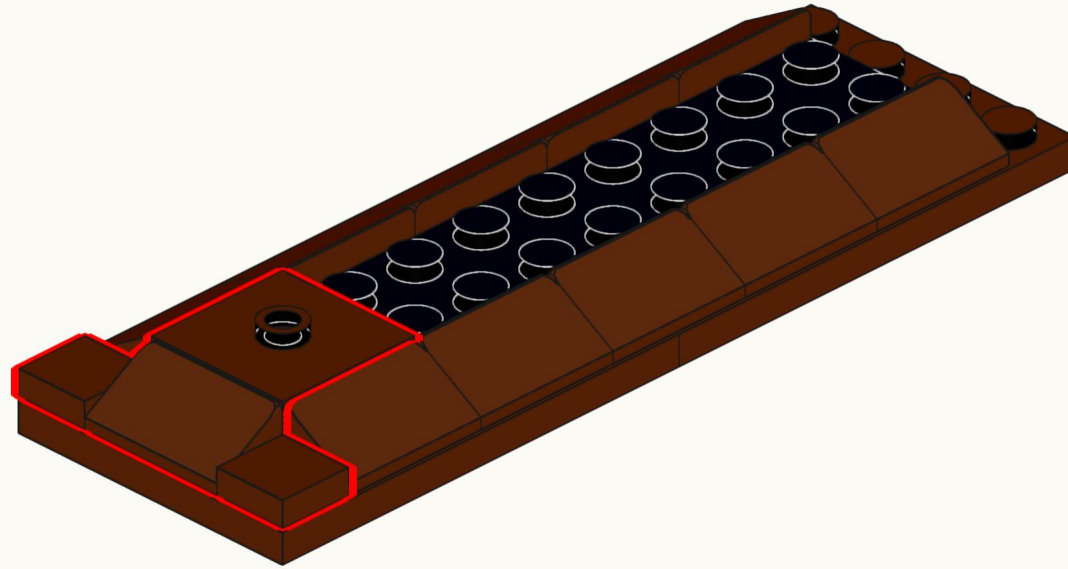

84

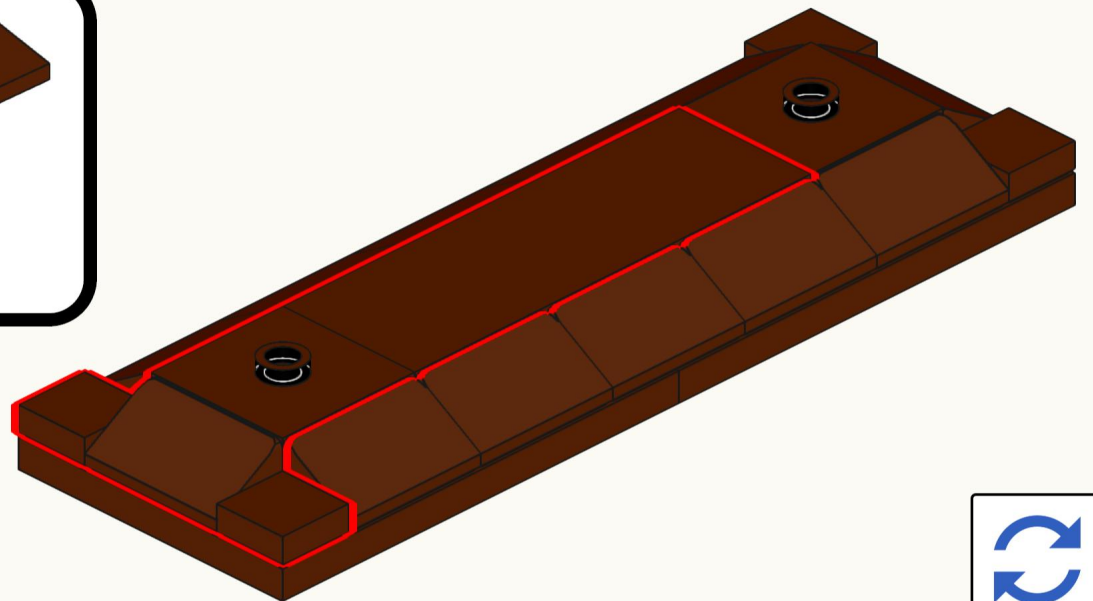

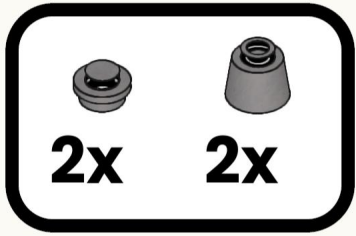

85

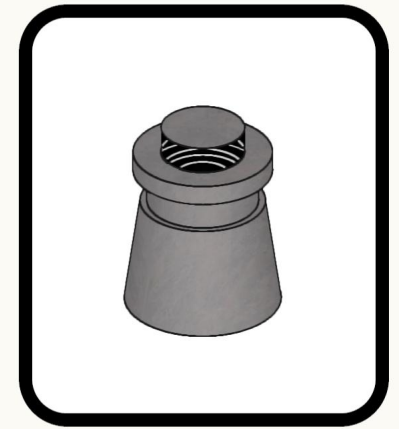
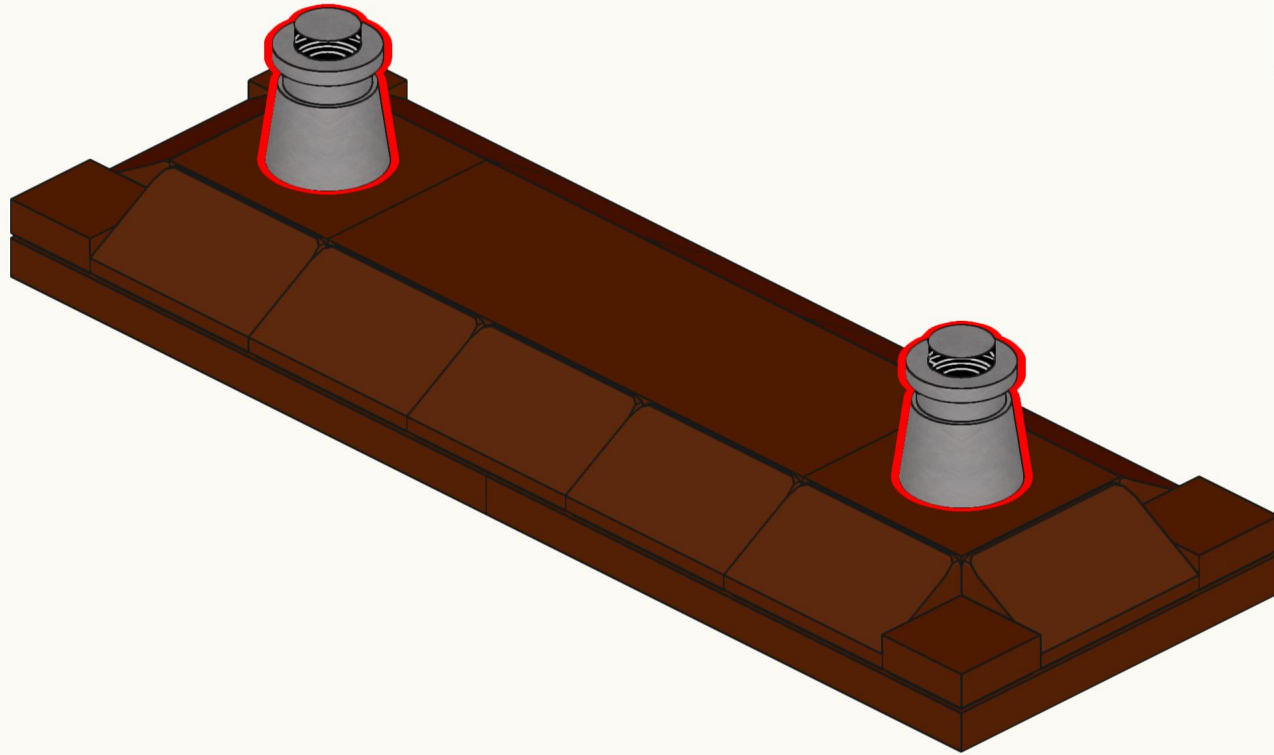

2x

86

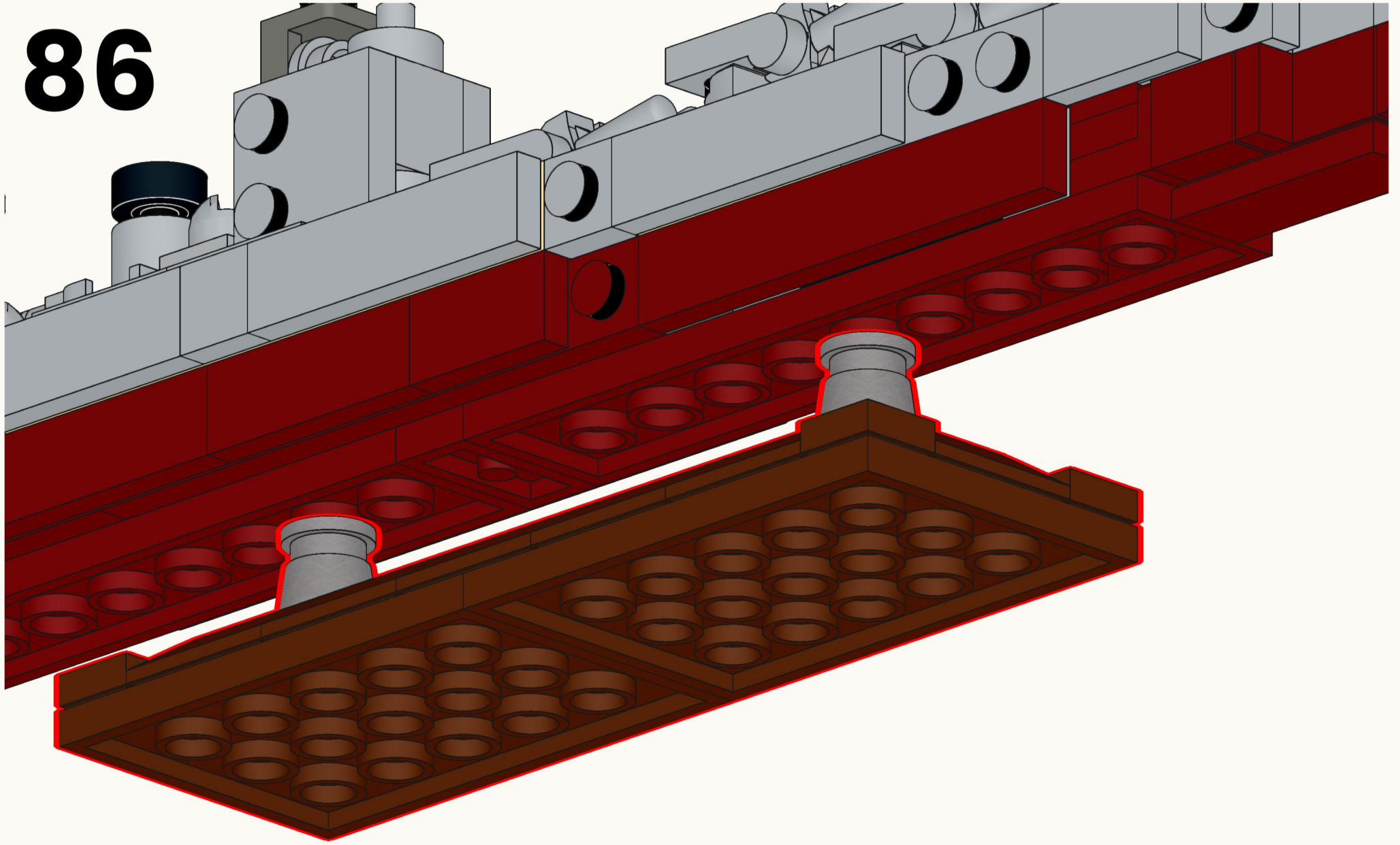

Display the completed model on its display stand or add it to a naval-themed diorama!

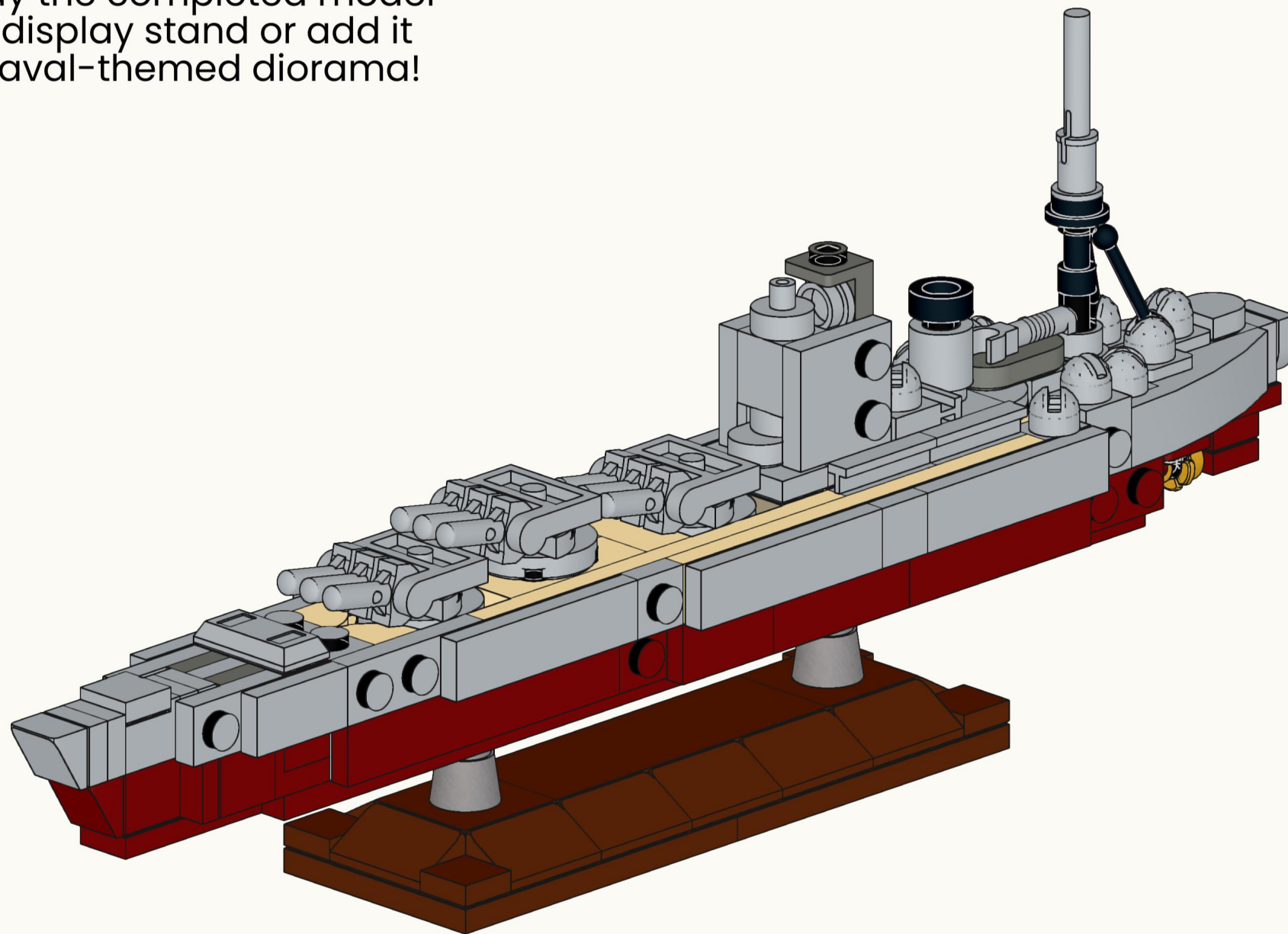

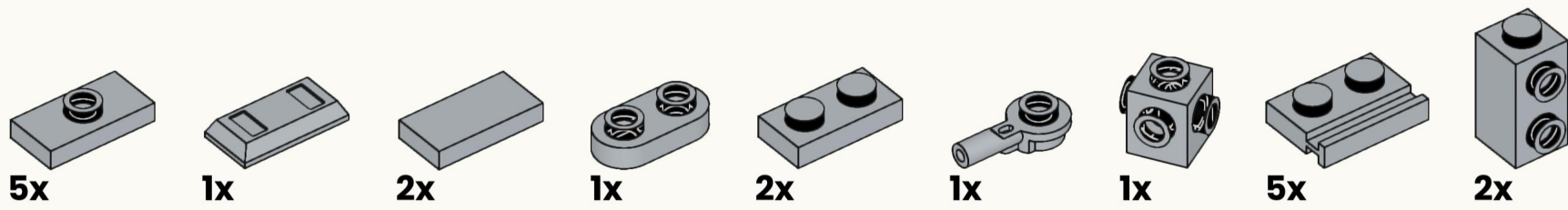
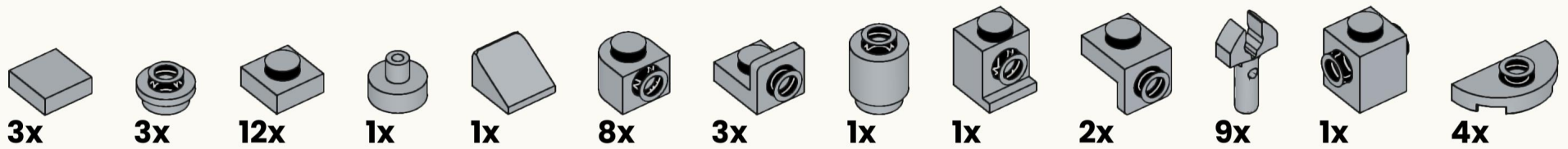
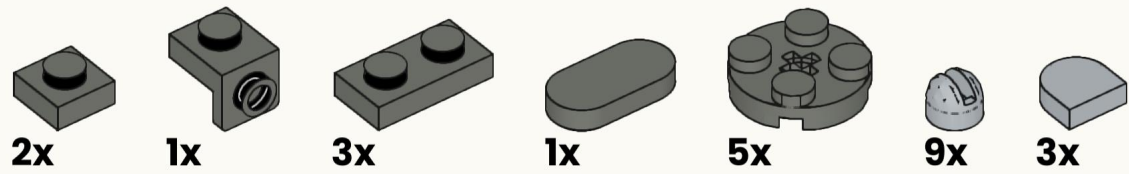
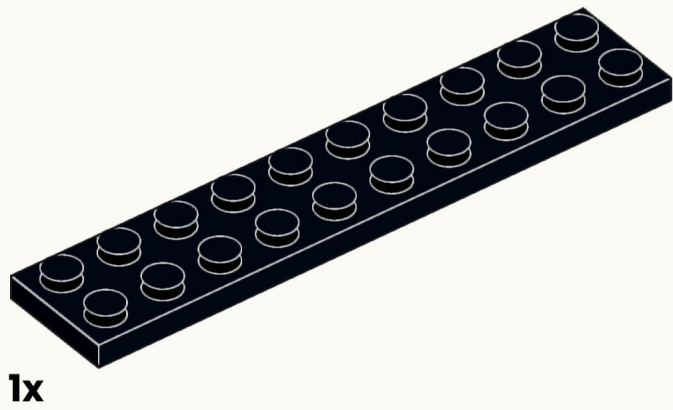
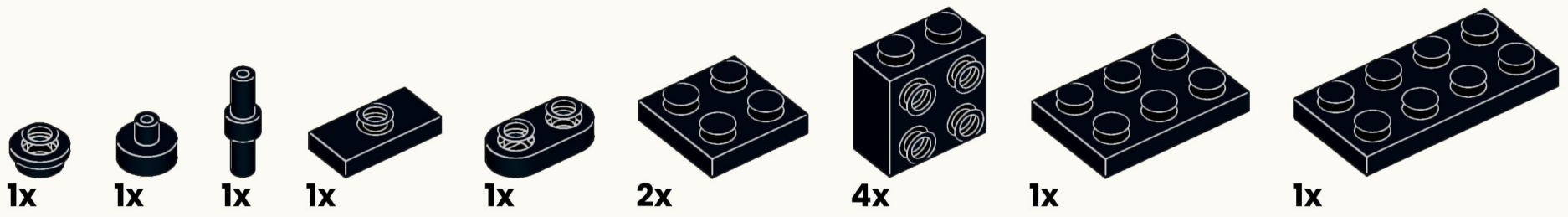

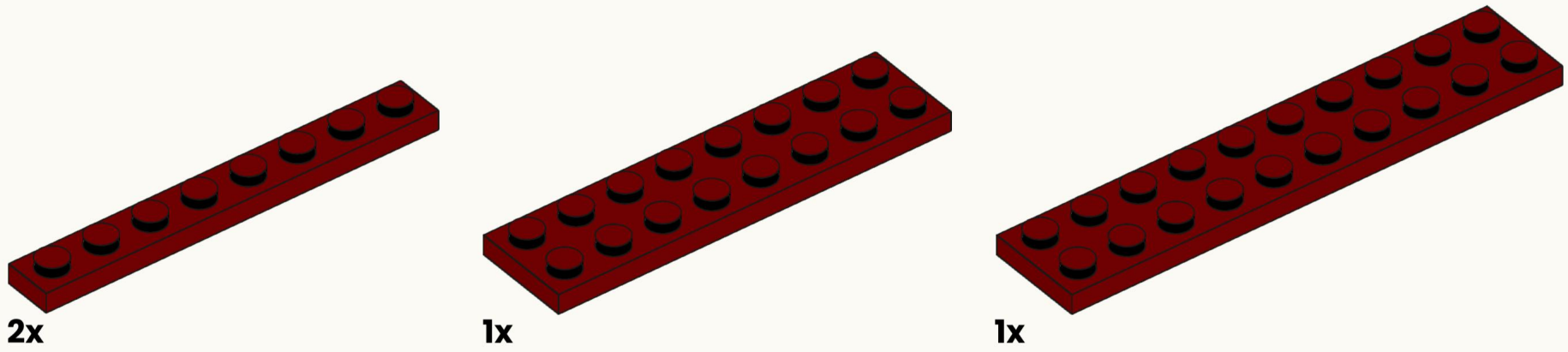
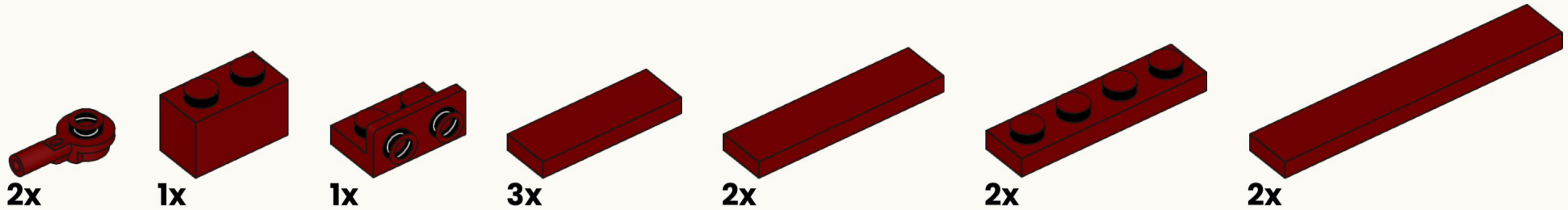
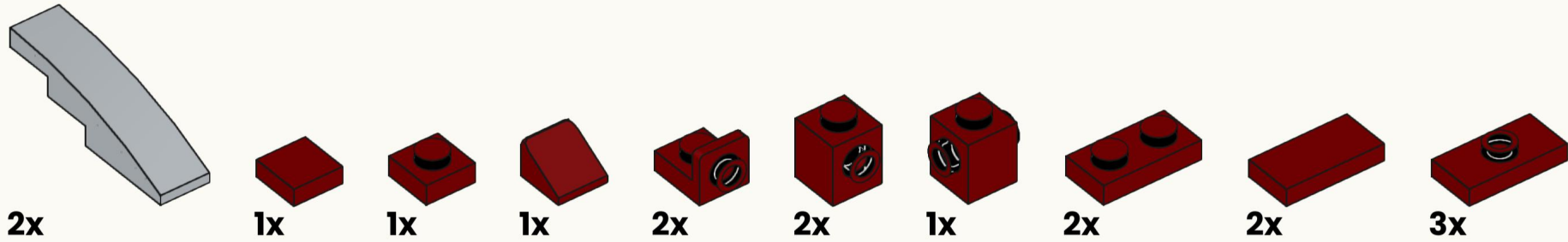
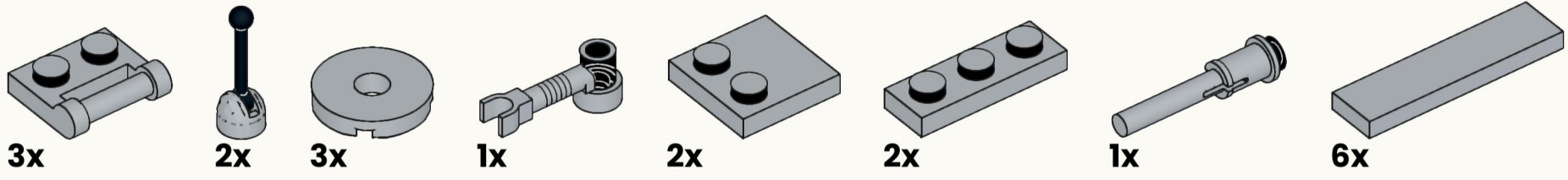



4x



12x

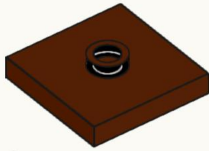

2x

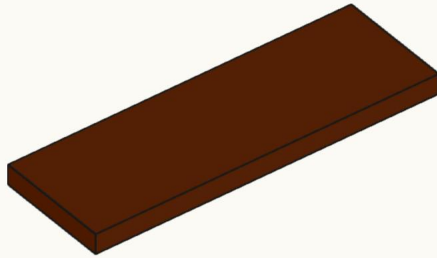

1x

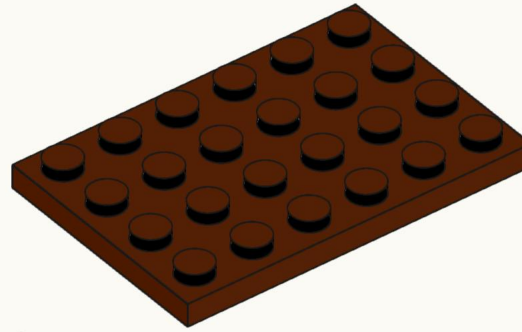

2x

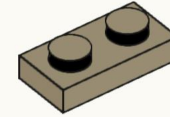

1x

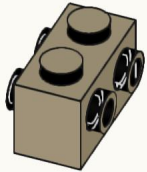

1x



2x

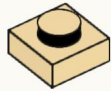

2x



2x

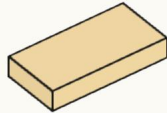

1x

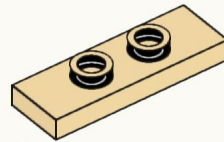

2x

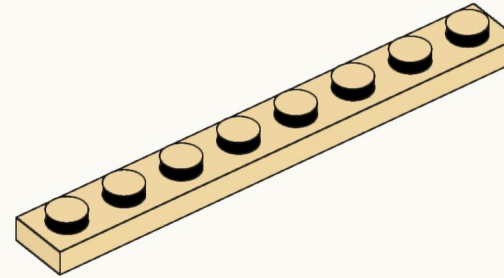

4x

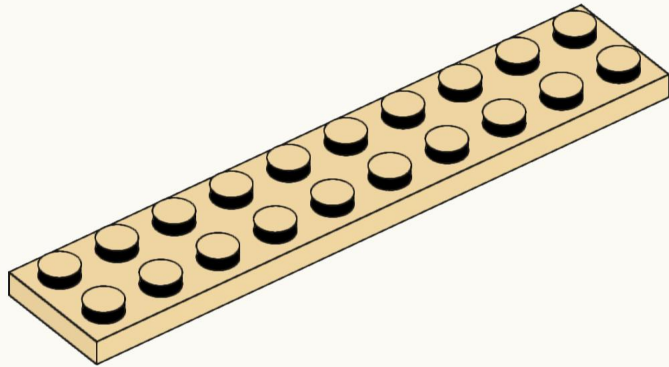

1x

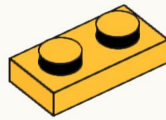

4x



2x



2x



2x

# **BOBBY BRIX**

**DESIGNED BY BOBBY BRIX IN 2026.  
ALL RIGHTS RESERVED.**